

LINEAR IC

# QUAD OPERATIONAL AMPLIFIER

## MB3614

### QUAD OPERATIONAL AMPLIFIER OPERATES FROM A SINGLE OR DUAL POWER SUPPLY

The Fujitsu MB3614 is a Quad operational amplifier having a phase compensatory circuitry and operates from a single power supply or dual power supplies.

The device has equivalent electrical characteristics of current industrial standard operational amplifier and requires low power supply current.

MB3614 can be high density mounted because it integrates 4 circuits in DIP/FPT 14-pin package.

- No phase compensation required
- Wide power supply voltage
  - Single power supply: +3 to +30 V
  - Dual power supplies:  $\pm 1.5$  to  $\pm 15$  V
- Wide input common mode range: 0 to ( $V_{CC} - 1.5$ ) V
- Low power supply current: 0.8 mA typ.
- Low input offset voltage: 2 mV typ.
- Package
  - 14-pin Plastic DIP package (Suffix: -P)
  - 14-pin Ceramic DIP package (Suffix: -Z)
  - 14-pin Plastic FPT package (Suffix: -PF)

### ■ ABSOLUTE MAXIMUM RATINGS (see NOTE)

( $T_A = 25^\circ\text{C}$ )

Rating	Symbol	Value	Unit
Power Supply Voltage	$V_{CC}$	36	V
Differential Input Voltage	$V_{ID}$	36	V
Input Common Mode Voltage	$V_I$	-0.3 to +36	V
Power Dissipation	$P_D$	570	mW
Operating Temperature	$T_A$	-20 to +75	$^\circ\text{C}$
Storage Temperature	Plastic	$T_{STG}$	-55 to +125 $^\circ\text{C}$
	Ceramic	$T_{STG}$	-65 to +150 $^\circ\text{C}$

**NOTE:** Permanent device damage may occur if the above **Absolute Maximum Ratings** are exceeded. Functional operation should be restricted to the conditions as detailed in the operational sections of this data sheet. Exposure to absolute maximum rating conditions for extended periods may affect device reliability.

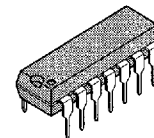

PLASTIC PACKAGE  
DIP-14P-M02

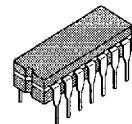

CERAMIC PACKAGE  
DIP-14C-C04

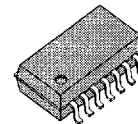

PLASTIC PACKAGE  
FPT-14P-M04

### PIN ASSIGNMENT (TOP VIEW)

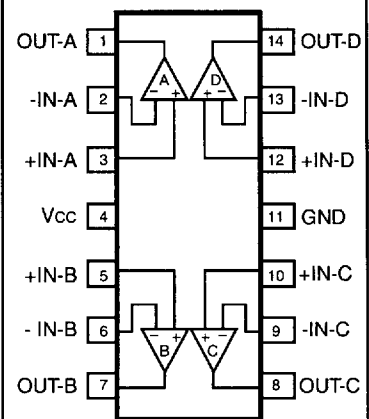

This device contains circuitry to protect the inputs against damage due to high static voltages or electric fields. However, it is advised that normal precautions be taken to avoid application of any voltage higher than maximum rated voltages to this high impedance circuit.

# MB3614

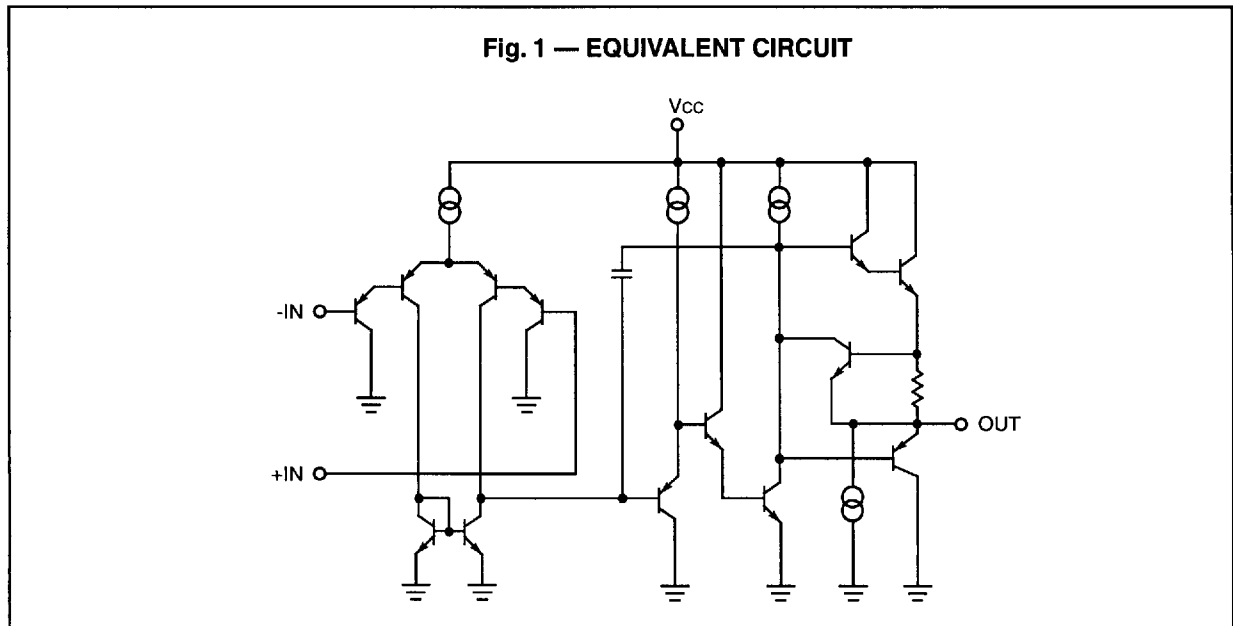

## ■ ELECTRICAL CHARACTERISTICS

( $V_{CC} = 5\text{ V}$ ,  $T_A = 25^\circ\text{C}$ )

Parameter	Symbol	Condition	Value			Unit
			Min	Typ	Max	
Input Offset Voltage	$V_{IO}$	—	—	2	7	mV
Input Offset Current	$I_{IO}$	—	—	5	50	nA
Input Bias Current	$I_{I^*}$	—	—	45	250	nA
Power Supply Current	$I_{CC}$	$R_L = \infty$	—	0.8	2.0	mA
Input Common Mode Voltage	$V_{CM}$	—	0	—	$V_{CC} - 1.5$	V
Voltage Gain	$A_v$	$R_L \geq 2\text{k}\Omega$	25	100	—	V/mV
Output Voltage	$V_{OH}$	$V_{CC} = 30\text{V}$ , $R_L = 2\text{k}\Omega$	26	28	—	V
	$V_{OL}$	$V_{CC} = 5\text{V}$ , $R_L \leq 10\text{k}\Omega$	—	5	20	mV
Output Current	$I_{SOURCE}$	$V_{CC} = 15\text{V}$ , $V_{IN} = +1\text{V}$	20	40	—	mA
	$I_{SINK}$	$V_{CC} = 15\text{V}$ , $V_{IN} = -1\text{V}$	10	20	—	mA
Common Mode Rejection Ratio	CMRR	—	65	85	—	dB
Power Supply Voltage Rejection Ratio	SVRR	—	65	100	—	dB
Channel Separation	CS	—	—	120	—	dB

Note:

\* A direction of the input bias current flows from IC because first input transistor consists of PNP.

■ TYPICAL CHARACTERISTICS CURVES

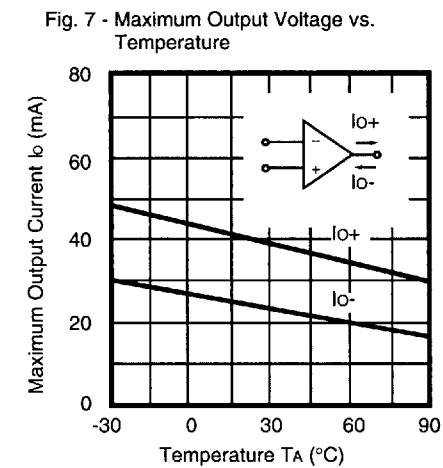
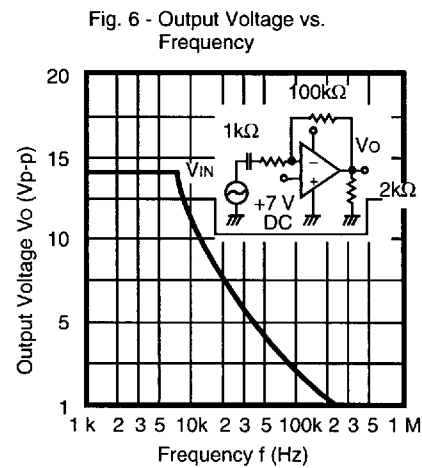
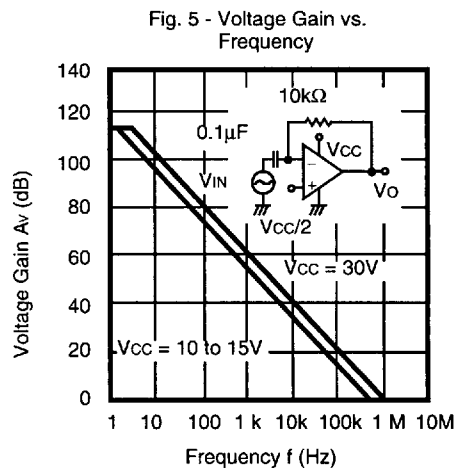
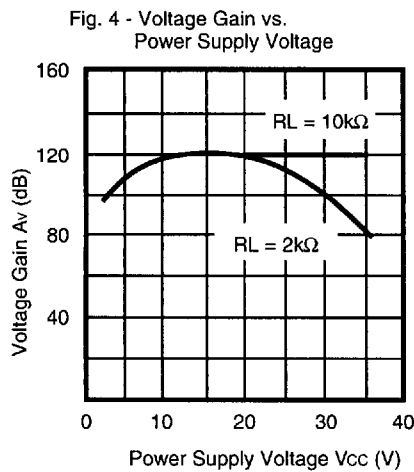
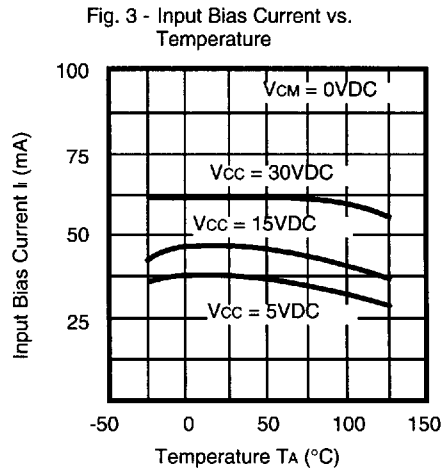
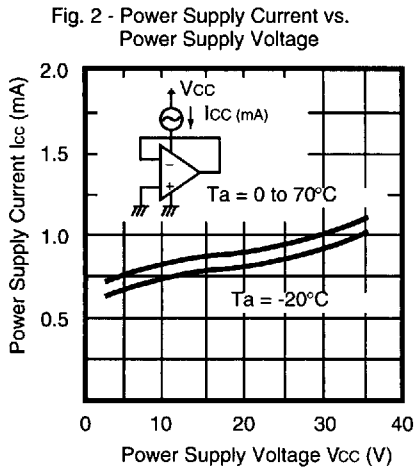

# MB3614

## ■ PACKAGE DIMENSIONS

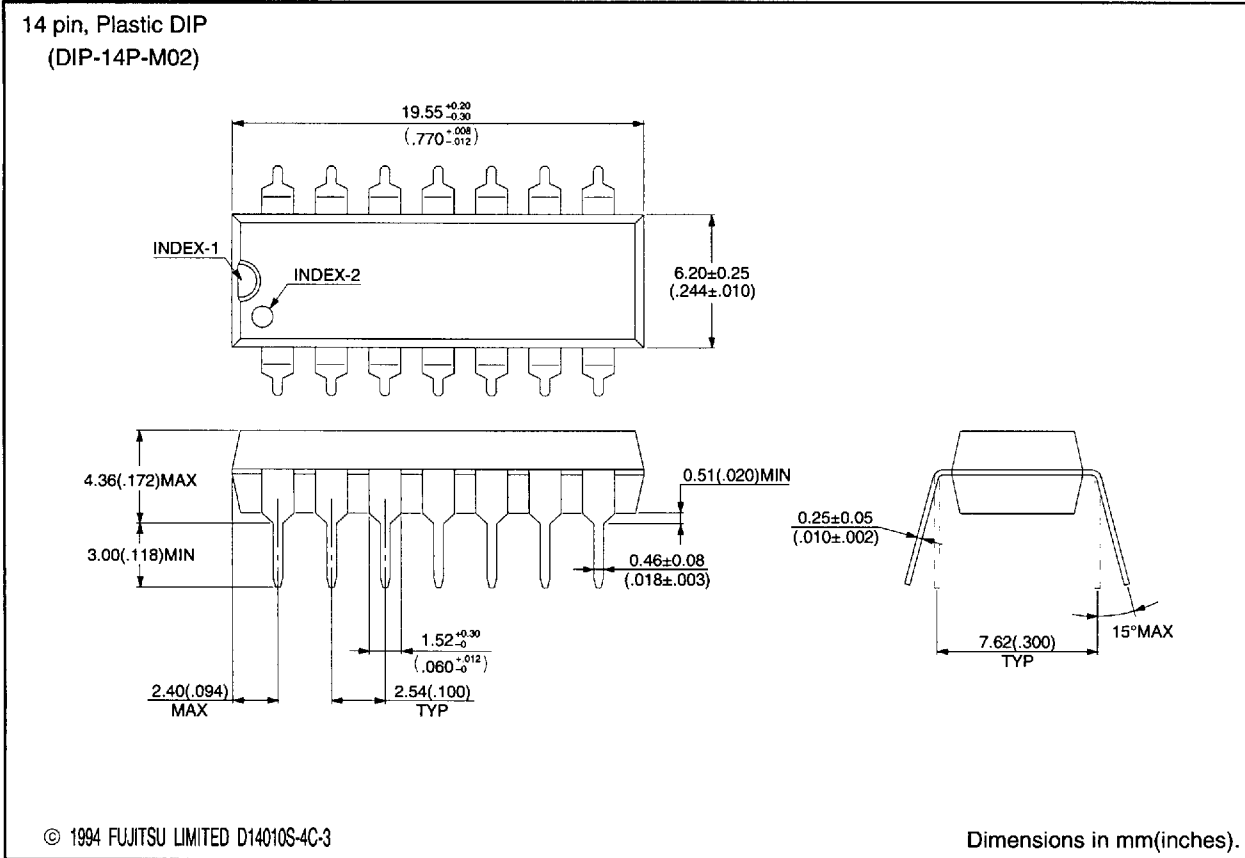

## ■ PACKAGE DIMENSIONS (Continued)

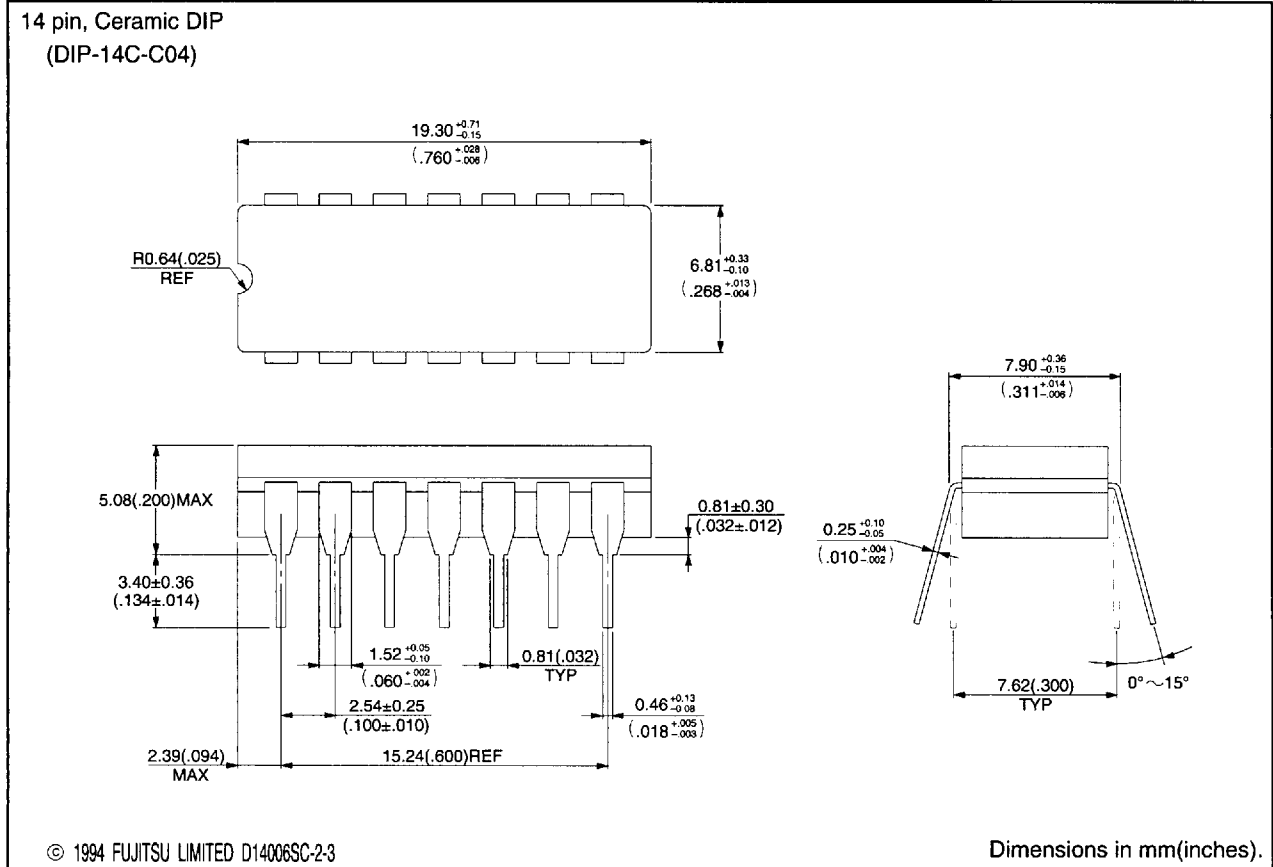

# MB3614

## ■ PACKAGE DIMENSIONS (Continued)

