

3110 SERIES 15 PIN HIGH DENSITY PCB RIGHT ANGLE TYPE

REV	DATE	DESCRIPTION	ECN NO.	NAME
A	04.07.31	NEW RELEASE		ZHYING

SUBMINATURE CONNECTORS FEMALE

MATERIAL

HOUSING : THERMOPLASTIC (UL94V-0)
 HOUSING COLOR : SEE ORDER INFORMATION
 TERMINAL : COPPER ALLOY
 TERMINAL PLATED : SEE ORDER INFORMATION
 SHELL : SEE ORDER INFORMATION
 BRACKET : COPPER ALLOY , NICKEL PLATED
 RIVET : COPPER ALLOY , NICKEL PLATED

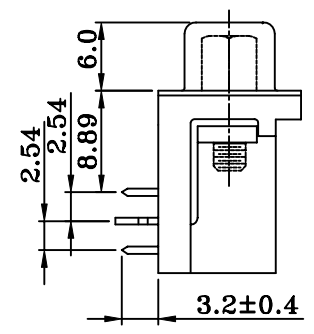
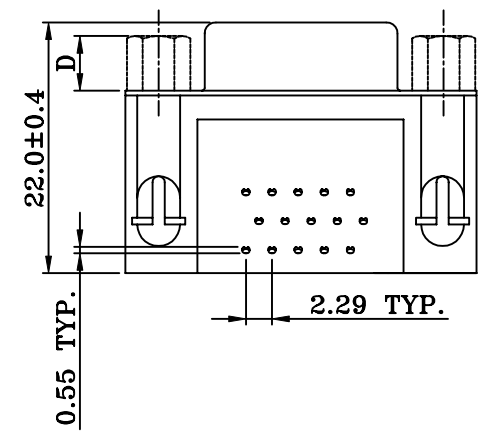
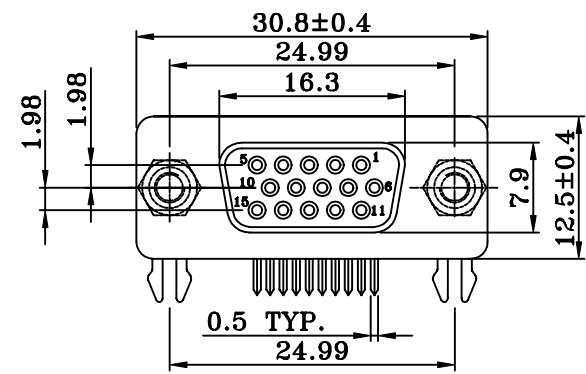
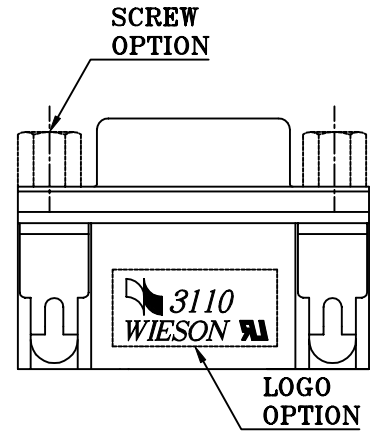
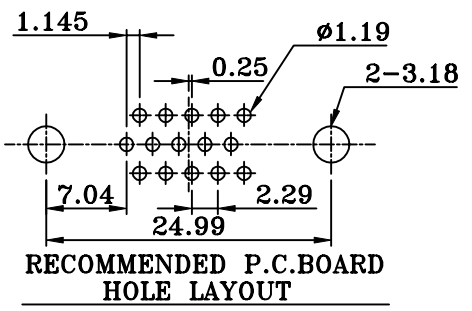

ORDER INFORMATION

G3110 - ** * * **
 "G":GREEN PRODUCTS
 05:BLUE(660C~662C)
 06:BLUE(299U2X)
 07:BLACK
 0:Ni,WITH MARK
 1:Ni,W/O MARK
 2:Tin,WITH MARK
 3:Tin,W/O MARK
 1:W/O SCREW
 2:SS6-A47511848
 3:SS6-A47513058
 4:ATTACHED SCREWS
 SS6-A47511848
 5:ATTACHED SCREWS
 SS6-A47513058

- 01:1u" min. Au IN CONTACT AREA, 100u" min. Tin IN SOLDER TAILS AREA, BOTH OVER 50u" min. Ni UNDERPLATED OVERALL.
- 02:5u" min. Au IN CONTACT AREA, 100u" min. Tin IN SOLDER TAILS AREA, BOTH OVER 50u" min. Ni UNDERPLATED OVERALL.
- 03:10u" min. Au IN CONTACT AREA, 100u" min. Tin IN SOLDER TAILS AREA, BOTH OVER 50u" min. Ni UNDERPLATED OVERALL.
- 04:15u" min. Au IN CONTACT AREA, 100u" min. Tin IN SOLDER TAILS AREA, BOTH OVER 50u" min. Ni UNDERPLATED OVERALL.
- 05:30u" min. Au IN CONTACT AREA, 100u" min. Tin IN SOLDER TAILS AREA, BOTH OVER 50u" min. Ni UNDERPLATED OVERALL.
- 06:3u" min. Au IN CONTACT AREA, 100u" min. Tin IN SOLDER TAILS AREA, BOTH OVER 50u" min. Ni UNDERPLATED OVERALL.
- 11:1u" min. Au OVER 50u" min. Ni UNDERPLATED OVERALL.
- 12:5u" min. Au OVER 50u" min. Ni UNDERPLATED OVERALL.
- 13:10u" min. Au OVER 50u" min. Ni UNDERPLATED OVERALL.
- 14:15u" min. Au OVER 50u" min. Ni UNDERPLATED OVERALL.
- 15:30u" min. Au OVER 50u" min. Ni UNDERPLATED OVERALL.
- 16:3u" min. Au OVER 50u" min. Ni UNDERPLATED OVERALL.

	D	INNER SCREW THREAD	OUTER SCREW THREAD
S:SS6-A47511848	4.8	#4-40 UNC	#4-40 UNC
2:SS6-A47513058	5.8	#4-40 UNC	#4-40 UNC

GENERAL TOLERANCE ±0.25mm GENERAL ANGLE TOLERANCE ±3°	WIESON TECHNOLOGIES CO., LTD		PART NO.: G3110-*****	
	DRAWN BY	ZHYING (WSC)	DRAWING NO.	G3110-*****
	CHECKED BY		DRAWING SIZE	2 : 1 A3
	APPROVED BY	KEVIN	UNIT	mm
SORTING NO. P1194 (WST)		PAGE 1 OF 1		

NOTE:P.C.B LAYOUT TOLERANCE:±0.05mm

ISSUED

[ARTICLE: 044033 V3]