

DATA SHEET

LLSD103A~LLSD103C

SMALL SIGNAL SCHOTTKY BARRIES SWITCHING DIODES

VOLTAGE 20 to 40 Volts **CURRENT** 0.35 Amperes

MINI-MELF/LL-34

Unit : inch (mm)

FEATURES

- Low Forward Voltage Drop
- Guard Ring Construction for Transient Protection
- Low Reverse Recovery Time
- Low Reverse Capacitance
- Both normal and Pb free product are available :
Normal : 80~95% Sn, 5~20% Pb
Pb free: 99% Sn above

MECHANICAL DATA

- Case: Molded Mini Melf, Glass
- Terminals: Solderable per MIL-STD-202G, Method 208
- Polarity: See Diagram Below
- Approx. Weight: 0.03 grams
- Mounting Position: Any
- Packing information

T/R - 2.5K per 7" plastic Reel

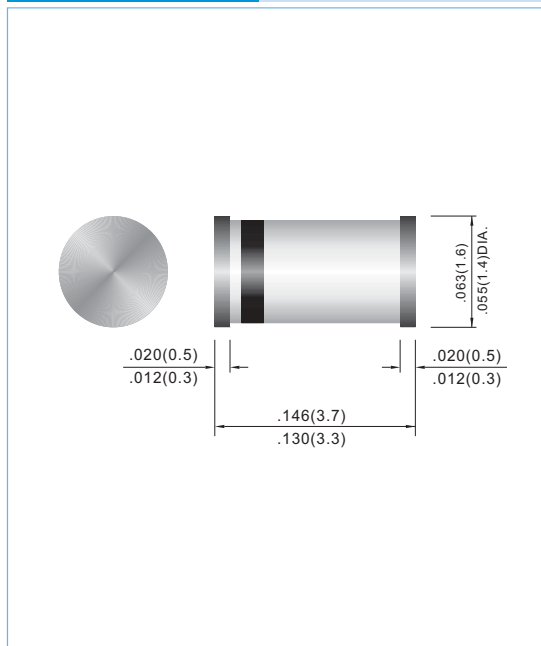

MAXIMUM RATINGS AND ELECTRICAL CHARACTERISTICS (T_J=25°C unless otherwise noted)

PARAMETER	SYMBOL	LLSD103A	LLSD103B	LLSD103C	UNITS
Peak Repetitive Reverse Voltage	V _{RRM}	40	30	20	V
RMS Reverse Voltage	V _{RMS}	28	21	14	V
Max. Average Rectified Current	I _O	350			mA
Peak Forward Surge Current, t ≤ 0.3ms	I _{FSM}	15			A
Power Dissipation Derate Above 25°C	P _D	400			mW
Maximum Forward Voltage, I _F = 20mA I _F = 200mA	V _F	0.37 0.70			V
Maximum Reverse Current	I _R	5 @ 30V	5 @ 20V	5 @ 10V	uA
Typical Junction Capacitance(Note 1)	C _J	50			pF
Typical Reverse Recovery (Note 2)	T _{RR}	10			ns
Maximum Thermal Resistance	R _{θJA}	250			°C / W
Storage Temperature Range	T _{STG}	-65 TO +175			°C

NOTE:

1. C_J at V_R=0, f=1MHZ
2. From I_F=50mA to I_R=200mA, R_L=100Ω

RATING AND CHARACTERISTIC CURVES

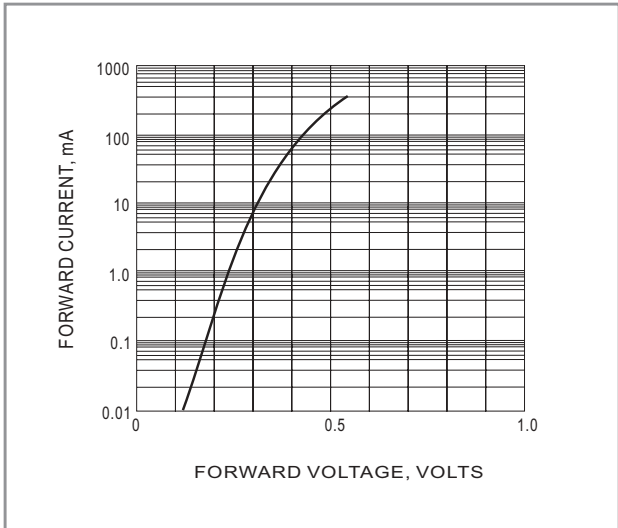

Fig.1 FORWARD CHARACTERISTICS

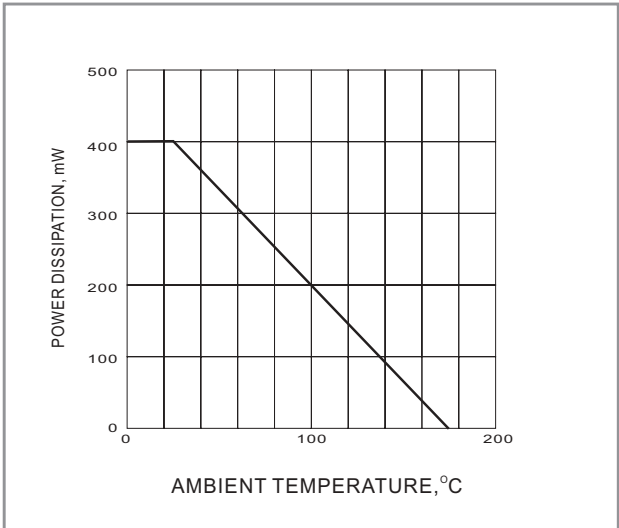

Fig.2- POWER DISSIPATION DERATING CURVE

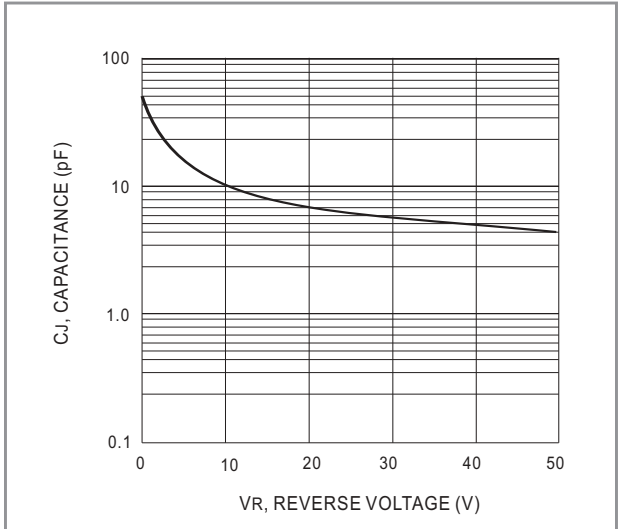

Fig.3 TYPICAL CAPACITANCE vs REVERSE VOLATGE