

SN54HC356, SN74HC356
8-LINE TO 1-LINE DATA SELECTORS/MULTIPLEXERS/
EDGE-TRIGGERED REGISTERS WITH 3-STATE OUTPUTS

D2684, DECEMBER 1982—REVISED SEPTEMBER 1987

T-672151

- Transparent Latches on Data Select Inputs
- Edge-Triggered Data Registers
- High-Current 3-State Outputs Can Drive Up to 15 LSTTL Loads
- Complementary Outputs
- Package Options Include Plastic "Small Outline" Packages, Ceramic Chip Carriers, and Standard Plastic and Ceramic 300-mil DIPs
- Dependable Texas Instruments Quality and Reliability

SN54HC356 . . . J PACKAGE
 SN74HC356 . . . DW OR N PACKAGE
 (TOP VIEW)

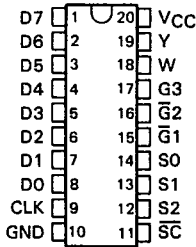

SN54HC356 . . . FK PACKAGE
 (TOP VIEW)

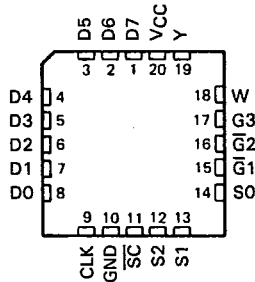

2
HCMOS Devices

description

These monolithic data selectors/multiplexers contain full on-chip binary decoding to select one of eight data sources. The data-select address is stored in transparent latches that are enabled by a low level in pin 11, SC. The edge-triggered data registers are clocked by a low-to-high transition on pin 9, CLK. Both true and complementary outputs are available.

The SN54HC356 is characterized for operation over the full military temperature range of -55°C to 125°C. The SN74HC356 is characterized for operation from -40°C to 85°C.

logic symbol†

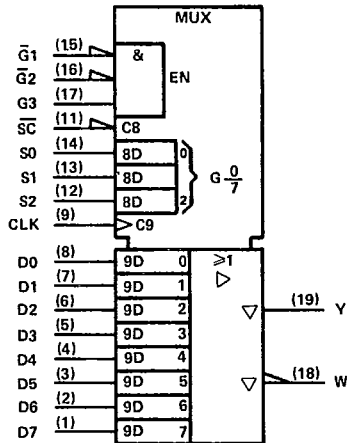

† This symbol is in accordance with ANSI/IEEE Std 91-1984 and IEC Publication 617-12.

PRODUCTION DATA documents contain information current as of publication date. Products conform to specifications per the terms of Texas Instruments standard warranty. Production processing does not necessarily include testing of all parameters.



Copyright © 1982, Texas Instruments Incorporated

2-401

T-67-21-51

logic diagram (positive logic)

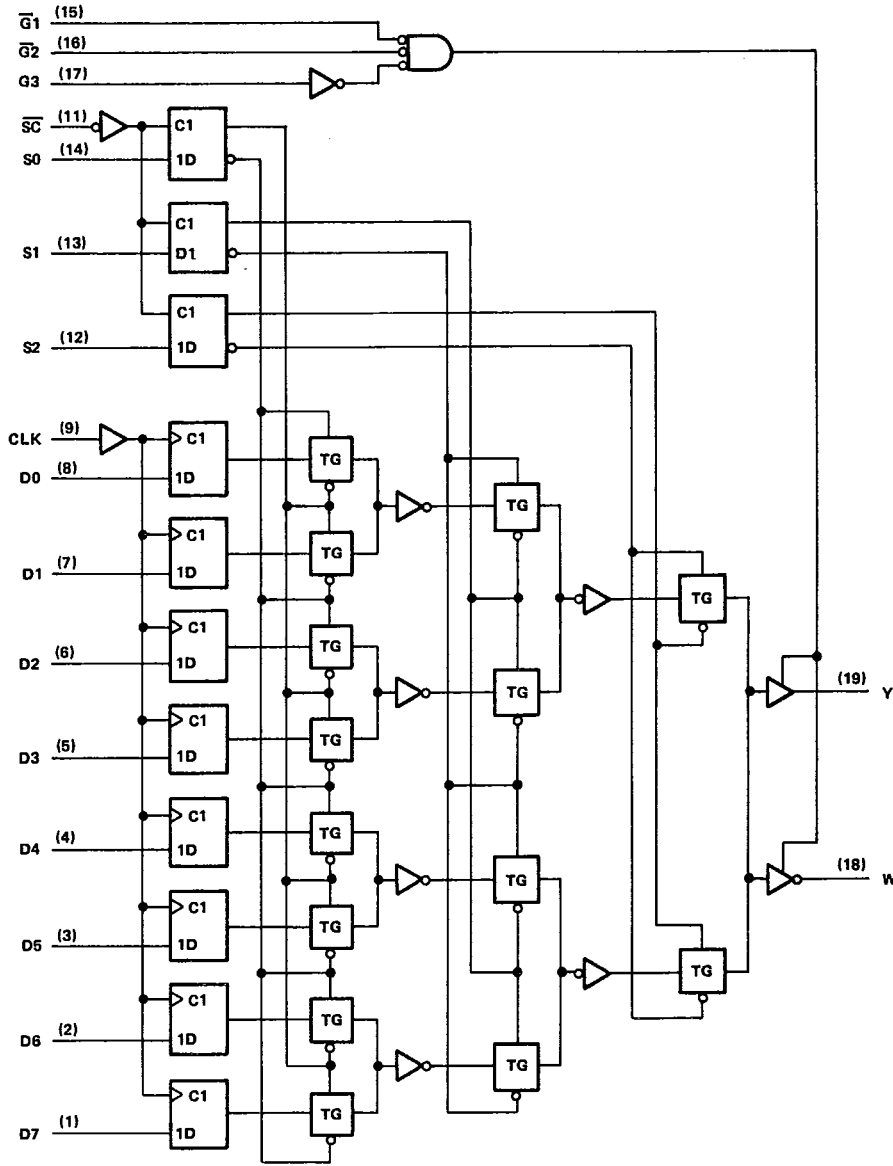

2 HCMOS Devices

SN54HC356, SN74HC356
 8-LINE TO 1-LINE DATA SELECTORS/MULTIPLEXERS/
 EDGE-TRIGGERED REGISTERS WITH 3-STATE OUTPUTS

T.67-21-51

FUNCTION TABLE

SELECT†			INPUTS			OUTPUTS		
			CLOCK	OUTPUT ENABLES				
S2	S1	S0		Ġ1	Ġ2	G3	W	Y
X	X	X	X	H	X	X	Z	Z
X	X	X	X	X	X	H	X	Z
X	X	X	X	X	X	X	L	Z
L	L	L	L	†	L	L	H	D0
L	L	L	L	H or L	L	L	H	D0 _n
L	L	L	H	†	L	L	H	D1
L	L	L	H	H or L	L	L	H	D1 _n
L	H	L	L	†	L	L	H	D2
L	H	L	L	H or L	L	L	H	D2 _n
L	H	L	H	†	L	L	H	D3
L	H	L	H	H or L	L	L	H	D3 _n
H	L	L	L	†	L	L	H	D4
H	L	L	L	H or L	L	L	H	D4 _n
H	L	L	H	†	L	L	H	D5
H	L	L	H	H or L	L	L	H	D5 _n
H	H	L	L	†	L	L	H	D6
H	H	L	L	H or L	L	L	H	D6 _n
H	H	L	H	†	L	L	H	D7
H	H	L	H	H or L	L	L	H	D7 _n

†This column shows the input address setup with \overline{SC} low.

2

HCMOS Devices

absolute maximum ratings over operating free-air temperature range‡

- Supply voltage, VCC -0.5 V to 7 V
- Input clamp current, I_{IK} (V_I < 0 or V_I > VCC) ± 20 mA
- Output clamp current, I_{OK} (V_O < 0 or V_O > VCC) ± 20 mA
- Continuous output current, I_O (V_O = 0 to VCC) ± 35 mA
- Continuous current through VCC or GND pins ± 70 mA
- Lead temperature 1,6 mm (1/16 in) from case for 60 s: FK or J package 300°C
- Lead temperature 1,6 mm (1/16 in) from case for 10 s: DW or N package 260°C
- Storage temperature range -65°C to 150°C

‡Stresses beyond those listed under "absolute maximum ratings" may cause permanent damage to the device. These are stress ratings only, and functional operation of the device at these or any other conditions beyond those indicated under "recommended operating conditions" is not implied. Exposure to absolute-maximum-rated conditions for extended periods may affect device reliability.



POST OFFICE BOX 855012 • DALLAS, TEXAS 75285

2-403

T-67-21-51

SN54HC356, SN74HC356
8-LINE TO 1-LINE DATA SELECTORS/MULTIPLEXERS/
EDGE-TRIGGERED REGISTERS WITH 3-STATE OUTPUTS

recommended operating conditions

		SN54HC356			SN74HC356			UNIT
		MIN	NOM	MAX	MIN	NOM	MAX	
V _{CC}	Supply voltage	2	5	6	2	5	6	V
V _{IH}	High-level input voltage	V _{CC} = 2 V		1.5	1.5		V	
		V _{CC} = 4.5 V		3.15	3.15			
		V _{CC} = 6 V		4.2	4.2			
V _{IL}	Low-level input voltage	V _{CC} = 2 V		0	0.3	0	0.3	V
		V _{CC} = 4.5 V		0	0.9	0	0.9	
		V _{CC} = 6 V		0	1.2	0	1.2	
V _I	Input voltage	0	V _{CC}		0	V _{CC}		V
V _O	Output voltage	0	V _{CC}		0	V _{CC}		V
t _t	Input transition (rise and fall) times	V _{CC} = 2 V		0	1000	0	1000	ns
		V _{CC} = 4.5 V		0	500	0	500	
		V _{CC} = 6 V		0	400	0	400	
T _A	Operating free-air temperature	-55	125		-40	85		°C

electrical characteristics over recommended operating free-air temperature range (unless otherwise noted)

PARAMETER	TEST CONDITIONS	V _{CC}	T _A = 25°C		SN54HC356		SN74HC356		UNIT
			MIN	MAX	MIN	MAX	MIN	MAX	
V _{OH}	V _I = V _{IH} or V _{IL} , I _{OH} = -20 μA	2 V	1.9	1.998	1.9	1.9	V		
		4.5 V	4.4	4.499	4.4	4.4			
		6 V	5.9	5.999	5.9	5.9			
	V _I = V _{IH} or V _{IL} , I _{OH} = -6 mA	4.5 V	3.98	4.30	3.7	3.84			
V _I = V _{IH} or V _{IL} , I _{OH} = -7.8 mA	6 V	5.48	5.80	5.2	5.34				
V _{OL}	V _I = V _{IH} or V _{IL} , I _{OL} = 20 μA	2 V	0.002	0.1	0.1	0.1	V		
		4.5 V	0.001	0.1	0.1	0.1			
		6 V	0.001	0.1	0.1	0.1			
	V _I = V _{IH} or V _{IL} , V _{OL} = 6 mA	4.5 V	0.17	0.26	0.4	0.33			
V _I = V _{IH} or V _{IL} , I _{OL} = 7.8 mA	6 V	0.15	0.26	0.4	0.33				
I _I	V _I = V _{CC} or 0	6 V	±0.1	±100	±1000	±1000	nA		
I _{OZ}	V _O = V _{CC} or 0	6	±0.01	±0.5	±10	±5	μA		
I _{CC}	V _I = V _{CC} or 0, I _O = 0	6 V	8		160	80	μA		
C _i		2 to 6 V	3	10	10	10	pF		

2 HCMOS Devices



T-67-21-51

SN54HC356, SN74HC356
8-LINE TO 1-LINE DATA SELECTORS/MULTIPLEXERS/
EDGE-TRIGGERED REGISTERS WITH 3-STATE OUTPUTS

timing requirements over recommended operating free-air temperature range (unless otherwise noted)

	VCC	TA = 25°C		SN54HC356		SN74HC356		UNIT
		MIN	MAX	MIN	MAX	MIN	MAX	
f _{clock} Clock frequency	2 V	0	6	0	4.2	0	5	MHz
	4.5 V	0	31	0	21	0	25	
	6 V	0	33	0	25	0	28	
t _w Pulse duration	CLK high or low	2 V	80	120	100	ns		
		4.5 V	16	24	20			
		6 V	15	20	18			
	\overline{SC} low	2 V	80	120	100	ns		
		4.5 V	16	24	20			
		6 V	15	20	18			
t _{su} Setup time	Data before CLK↑	2 V	75	115	95	ns		
		4.5 V	15	23	19			
		6 V	13	20	16			
	Select before \overline{SC} ↑	2 V	75	115	95	ns		
		4.5 V	15	23	19			
		6 V	13	20	16			
t _h Hold time	Data after CLK↑	2 V	5	5	5	ns		
		4.5 V	5	5	5			
		6 V	5	5	5			
	Select after \overline{SC} ↑	2 V	5	5	5	ns		
		4.5 V	5	5	5			
		6 V	5	5	5			

2
HCMOS Devices



POST OFFICE BOX 655012 • DALLAS, TEXAS 75265

2-405

T-67-21-51

SN54HC356, SN74HC356
8-LINE TO 1-LINE DATA SELECTORS/MULTIPLEXERS/
EDGE-TRIGGERED REGISTERS WITH 3-STATE OUTPUTS

switching characteristics over recommended operating free-air temperature range (unless otherwise noted), $C_L = 50$ pF

PARAMETER	FROM (INPUT)	TO (OUTPUT)	V _{CC}	T _A = 25°C			SN54HC356		SN74HC356		UNIT
				MIN	TYP	MAX	MIN	MAX	MIN	MAX	
f _{max}	CLK		2 V	6			4.2	5		MHz	
			4.5 V	31			21	25			
			6 V	33			25	28			
t _{pd}	CLK	W or Y	2 V	100	225		338	318		ns	
			4.5 V	36	51		77	64			
			6 V	28	43		64	53			
t _{pd}	S0, S1 or S2	W or Y	2 V	120	285		427	355		ns	
			4.5 V	42	57		86	71			
			6 V	34	48		72	60			
t _{pd}	\overline{SC}	W or Y	2 V	120	300		450	375		ns	
			4.5 V	45	60		90	75			
			6 V	36	51		77	64			
t _{en}	$\overline{G1}, \overline{G2},$ or G3	W or Y	2 V	50	125		188	155		ns	
			4.5 V	18	25		38	31			
			6 V	15	21		32	26			
t _{dis}	$\overline{G1}, \overline{G2},$ or G3	W or Y	2 V	68	165		248	205		ns	
			4.5 V	24	33		50	41			
			6 V	20	28		42	35			
t _t		W or Y	2 V	28	60		90	75		ns	
			4.5 V	8	12		18	15			
			6 V	6	10		15	13			

C _{pd}	Power dissipation capacitance	No load, T _A = 25°C	100 pF typ
-----------------	-------------------------------	--------------------------------	------------

switching characteristics over recommended operating free-air temperature range (unless otherwise noted), $C_L = 150$ pF (see Note 1)

PARAMETER	FROM (INPUT)	TO (OUTPUT)	V _{CC}	T _A = 25°C			SN54HC356		SN74HC356		UNIT
				MIN	TYP	MAX	MIN	MAX	MIN	MAX	
t _{pd}	CLK	W or Y	2 V	110	295		442	365		ns	
			4.5 V	42	59		89	73			
			6 V	34	50		75	62			
t _{pd}	S0, S1, S2	W or Y	2 V	130	325		485	405		ns	
			4.5 V	50	65		97	81			
			6 V	40	55		82	69			
t _{pd}	\overline{SC}	W or Y	2 V	110	340		510	425		ns	
			4.5 V	52	68		102	85			
			6 V	42	58		87	72			
t _{en}	$\overline{G1}, \overline{G2},$ or G3	W or Y	2 V	60	165		248	205		ns	
			4.5 V	25	33		50	41			
			6 V	21	28		42	35			
t _t		Any	2 V	37	210		315	265		ns	
			4.5 V	12	42		63	53			
			6 V	10	36		53	45			

NOTE 1: Load circuit and voltage waveforms are shown in Section 1.

