



Description

The MK1726-01A/-02A/-04A devices generate a low EMI output clock from a clock or crystal input. The part is designed to dither the LCD interface clock for PDAs, printers, scanners, modems, copiers, etc. Using ICS' proprietary mix of analog and digital Phase Locked Loop (PLL) technology, the device spreads the frequency spectrum of the output and reduces the frequency amplitude peaks by several dB. The MK1726-01A/-02A/-04A devices offer both centered and down spread from a high-speed clock input.

ICS offers many other clocks for computers and computer peripherals. Consult ICS when you need to remove crystals and oscillators from your board.

Features

- Packaged in 8-pin SOIC/TSSOP
- Provides a spread spectrum output clock
- Supports flat panel controllers
- Accepts a clock or crystal input (provides same frequency dithered output)
- Input frequency range of 4 to 32 MHz.
- Output frequency range of 4 to 128 MHz
- 1X, 2X, 4X frequency multiplication
- 1X: MK1726-01A; 2X: MK1726-02A; 4X: MK1726-04A
- Center and down spread
- Peak reduction by 8 dB to 16 dB typical on 3rd through 19th odd harmonics
- Low EMI feature can be disabled
- Includes power down
- Operating voltage of 3.3 V
- Advanced, low-power CMOS process

Block Diagram

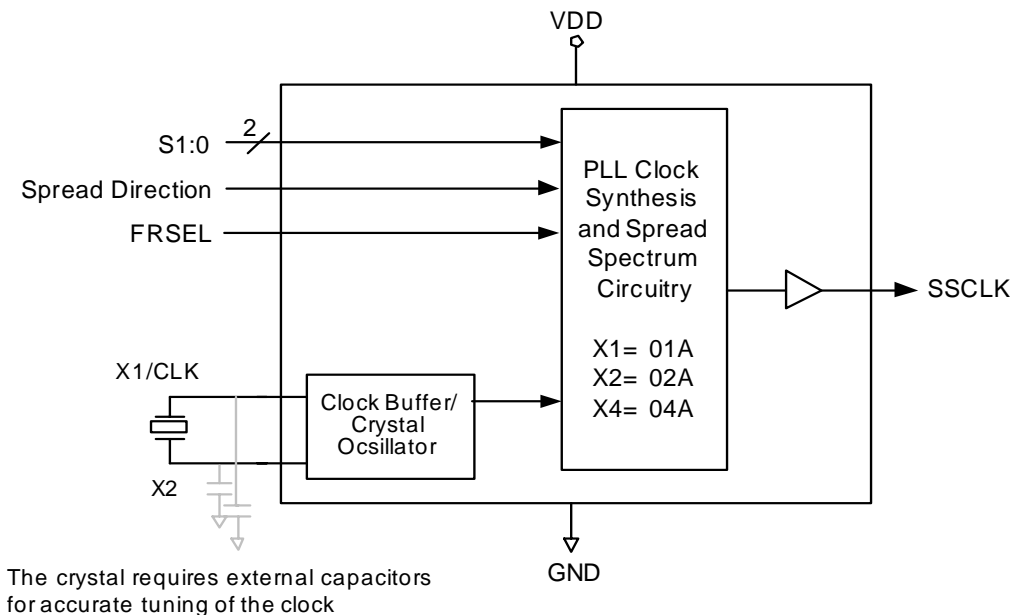



Pin Assignment

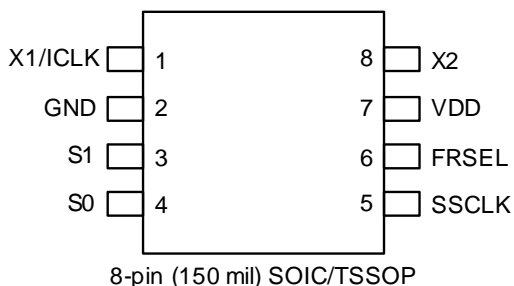

Spread Direction and Spread Percentage

S1 Pin 3	S0 Pin 4	Spread Direction	Spread Percentage
0	0	Center	±1.4
0	M	Center	±1.1
0	1	Center	±0.6
M	0	Center	±0.5
M	M	No Spread	-
M	1	Down	-1.6
1	0	Down	-2.0
1	M	Down	-0.7
1	1	Down	-3.0

0 = connect to GND

M = unconnected (floating)

1 = connect directly to VDD

Frequency Selection

Product	FRSEL (pin 6)	Input Freq. Range	Multiplier	Output Freq. Range
MK1726-01A	0	4.0 to 8.0 MHz	X1	4.0 to 8.0 MHz
MK1726-01A	1	8.0 to 16.0MHz	X1	8.0 to 16.0MHz
MK1726-01A	M	16.0 to 32.0MHz	X1	16.0 to 32.0MHz
MK1726-02A	0	4.0 to 8.0 MHz	X2	8.0 to 16.0MHz
MK1726-02A	1	8.0 to 16.0MHz	X2	16.0 to 32.0MHz
MK1726-02A	M	16.0 to 32.0MHz	X2	32.0 to 64.0MHz
MK1726-04A	0	4.0 to 8.0 MHz	X4	16.0 to 32.0MHz
MK1726-04A	1	8.0 to 16.0MHz	X4	32.0 to 64.0MHz
MK1726-04A	M	16.0 to 32.0MHz	X4	64.0 to 128MHz

0 = connect to GND

M = unconnected (floating)

1 = connect directly to VDD



Pin Descriptions

Pin Number	Pin Name	Pin Type	Pin Description
1	X1/ICLK	Input	Connect to 4-32 MHz crystal or clock.
2	GND	Power	Connect to ground.
3	S1	Input	Function select 1 input. Selects spread amount and direction per table above. (default-internal mid-level).
4	S0	Input	Function select 0 input. Selects spread amount and direction per table above. (default-internal mid-level).
5	SSCLK	Output	Clock output with Spread spectrum
6	FRSEL	Input	Function select for input frequency range. Default to mid level "M".
7	VDD	Power	Connect to +3.3 V.
8	X2	XO	Crystal connection to 4-32 MHz crystal. Leave unconnected for clock

External Components

The MK1726-01A/-02A/-04A devices require a minimum number of external components for proper operation.

Decoupling Capacitor

A decoupling capacitor of 0.01 μ F must be connected between VDD and GND on pins 7 and 2. Connect the capacitor as close to these pins as possible. For optimum device performance, mount the decoupling capacitor on the component side of the PCB. Avoid the use of vias in the decoupling circuit.

Series Termination Resistor

Use series termination when the PCB trace between the clock output and the load is over 1 inch. To series terminate a 50 Ω trace (a commonly used trace impedance), place a 33 Ω resistor in series with the clock line. Place the resistor as close to the clock output pin as possible. The nominal impedance of the clock output is 20 Ω .

Tri-level Select Pin Operation

The S1 and S0 select pins are tri-level, meaning that they have three separate states to make the selections shown in the table on page 2. To select the M (mid) level, the connection to these pins must be eliminated by either floating them originally, or tri-stating the GPIO pins which drive the select pins.

PCB Layout Recommendations

For optimum device performance and lowest output phase noise, observe the following guidelines:

- 1) Mount the 0.01 μ F decoupling capacitor on the component side of the board as close to the VDD pin as possible. No vias should be used between the decoupling capacitor and VDD pin. The PCB trace to the VDD pin and the PCB trace to the ground via should be kept as short as possible.
- 2) To minimize EMI, place the 33 Ω series-termination resistor (if needed) close to the clock output.
- 3) An optimum layout is one with all components on the same side of the board, thus minimizing vias through other signal layers. Other signal traces should be routed away from the MK1726A devices. This includes signal traces located underneath the device, or on layers adjacent to the ground plane layer used by the device.

Crystal Information

The crystal used should be a fundamental mode (do not use third overtone), parallel resonant crystal. To optimize the initial accuracy, connect crystal capacitors from pins X1 to ground and X2 to ground. The value of these capacitors is given by the following equation:

$$\text{Crystal caps (pF)} = (C_L - 6) \times 2$$



In the equation, C_L is the crystal load capacitance. For example, a crystal with a 16 pF load capacitance uses two 20 pF [(16-6) x 2] capacitors.

Spread Spectrum Profile

The MK1726-01A/-02A/-04A device's low EMI clock generator uses an optimized frequency slew rate algorithm to facilitate down stream tracking of zero delay buffers and other PLL devices.

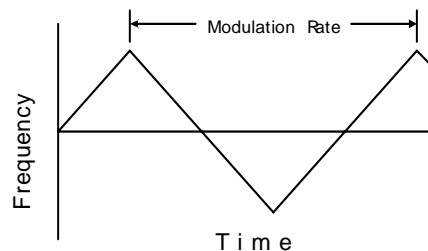

Absolute Maximum Ratings

Stresses above the ratings listed below can cause permanent damage to the MK1726A devices. These ratings, which are standard values for ICS commercially rated parts, are stress ratings only. Functional operation of the device, at these or any other conditions, above those indicated in the operational sections of the specifications is not implied. Exposure to absolute maximum rating conditions for extended periods can affect product reliability. Electrical parameters are guaranteed only over the recommended operating temperature range.

Item	Rating
Supply Voltage, VDD	7 V
All Inputs and Outputs	-0.5 V to VDD+0.5 V
Ambient Operating Temperature	0 to +85°C
Storage Temperature	-65 to +150°C
Junction Temperature	175°C
Soldering Temperature	260°C

Recommended Operation Conditions

Parameter	Min.	Typ.	Max.	Units
Ambient Operating Temperature	0		+70	°C
Power Supply Voltage (measured in respect to GND)	+3.0		3.63	V



DC Electrical Characteristics

Unless stated otherwise, $V_{DD} = 3.3\text{ V} \pm 10\%$, Ambient Temperature 0 to $+85^{\circ}\text{C}$

Parameter	Symbol	Conditions	Min.	Typ.	Max.	Units
Operating Voltage	VDD		3.0	3.3	3.63	V
Supply Current	IDD	No load, at 3.3 V, Fin=12 MHz		23	25	mA
		No load, at 3.3 V, Fin=24 MHz			30	mA
		No load, at 3.3 V, Fin=32 MHz			35	mA
Input High Voltage	V _{IH}		0.85VDD	VDD	VDD	V
Input middle Voltage	V _{IHM}		0.4VDD	0.5VDD	0.6	V
Input Low Voltage	V _{IL}		0.0	0.0	0.15	V
Output High Voltage	V _{OH}	CMOS, I _{OH} = -4 mA	2.4			V
Output High Voltage	V _{OH}	I _{OH} = -6 mA	2.0			V
Output Low Voltage	V _{OL}	I _{OL} = -4 mA			0.4	V
		I _{OL} = -10 mA			1.2	V
Input Capacitance	C _{IN1}	S0, S1, FRSEL pins		4	6	pF
	C _{IN2}	X1, X2 pins		6	9	pF

AC Electrical Characteristics

Unless stated otherwise, $V_{DD} = 3.3\text{ V} \pm 10\%$, Ambient Temperature 0 to $+85^{\circ}\text{C}$, C_L = 15 pF

Parameter	Symbol	Conditions	Min.	Typ.	Max.	Units
Input Clock Frequency			4		32	MHz
Output Clock Frequency			4		128	MHz
Input Clock Duty Cycle		Time above VDD/2	40		60	%
Output Clock Duty Cycle		Time above 1.5 V	45	50	55	%
Cycle-to-cycle Jitter (-01A)		Fin=4MHz, Fout=4 MHz		350	800	ps
Cycle-to-cycle Jitter (-01A)		Fin=8MHz, Fout=8 MHz		260	550	ps
Cycle-to-cycle Jitter (-02A)		Fin=8MHz, Fout=16 MHz		260	550	ps
Cycle-to-cycle Jitter (-02A)		Fin=16MHz, Fout=32 MHz		260	550	ps
Cycle-to-cycle Jitter (-04A)		Fin=16MHz, Fout=64 MHz		360	800	ps
Cycle-to-cycle Jitter (-04A)		Fin=32MHz, Fout=128 MHz		360	800	ps
Output Rise Time (-01A, -02A)	t _R	0.4 to 2.4 V	2.0	3.2	5.0	ns
Output Fall Time (-01A, -02A)	t _F	2.4 to 0.4 V	2.0	3.2	4.4	ns
FSEL = M (-04A only)	t _R		1.2	2.2	3.6	ns
	t _R		1.2	2.2	3.6	ns
FSEL = 1, 0 (-04A only)	t _F		2.2	4.3	6.9	ns
	t _F		2.2	4.3	6.9	ns
EMI Peak Frequency Reduction				8 to 16		dB

Package Outline and Package Dimensions (8-pin TSSOP)

Package dimensions are kept current with JEDEC Publication No. 95

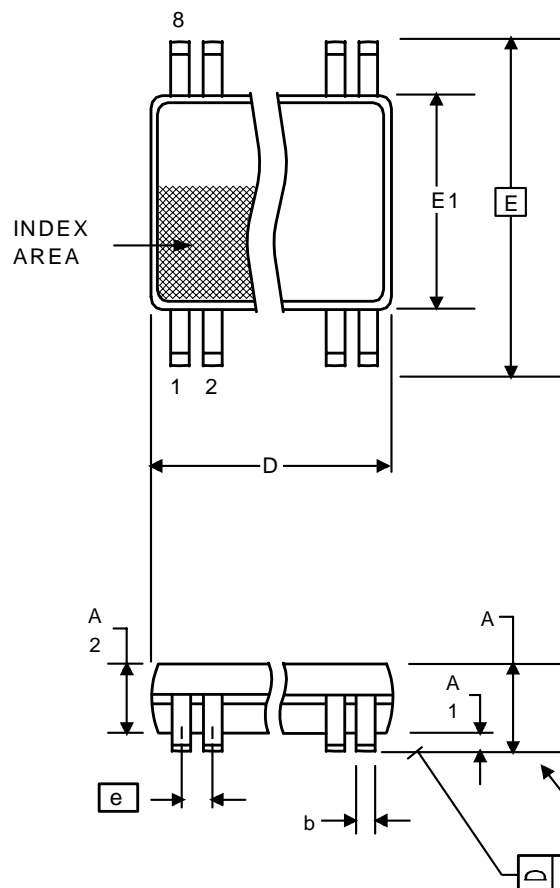

Symbol	Millimeters		Inches	
	Min	Max	Min	Max
A	--	1.20	--	0.047
A1	0.05	0.15	0.002	0.006
A2	0.80	1.05	0.032	0.041
b	0.19	0.30	0.007	0.012
C	0.09	0.20	0.0035	0.008
D	3.90	3.10	0.114	0.122
E	6.40 BASIC		0.252 BASIC	
E1	4.30	4.50	0.169	0.177
e	0.65 Basic		0.0256 Basic	
L	0.45	0.75	0.018	0.030
α	0°	8°	0°	8°
aaa	-	0.10	-	0.004

Thermal Characteristics for 8-pin TSSOP

Parameter	Symbol	Conditions	Min.	Typ.	Max.	Units
Thermal Resistance Junction to Ambient	θ_{JA}	Still air		110		°C/W
	θ_{JA}	1 m/s air flow		100		°C/W
	θ_{JA}	3 m/s air flow		80		°C/W
Thermal Resistance Junction to Case	θ_{JC}			35		°C/W



Package Outline and Package Dimensions (8-pin SOIC, 150 Mil. Body)

Package dimensions are kept current with JEDEC Publication No. 95

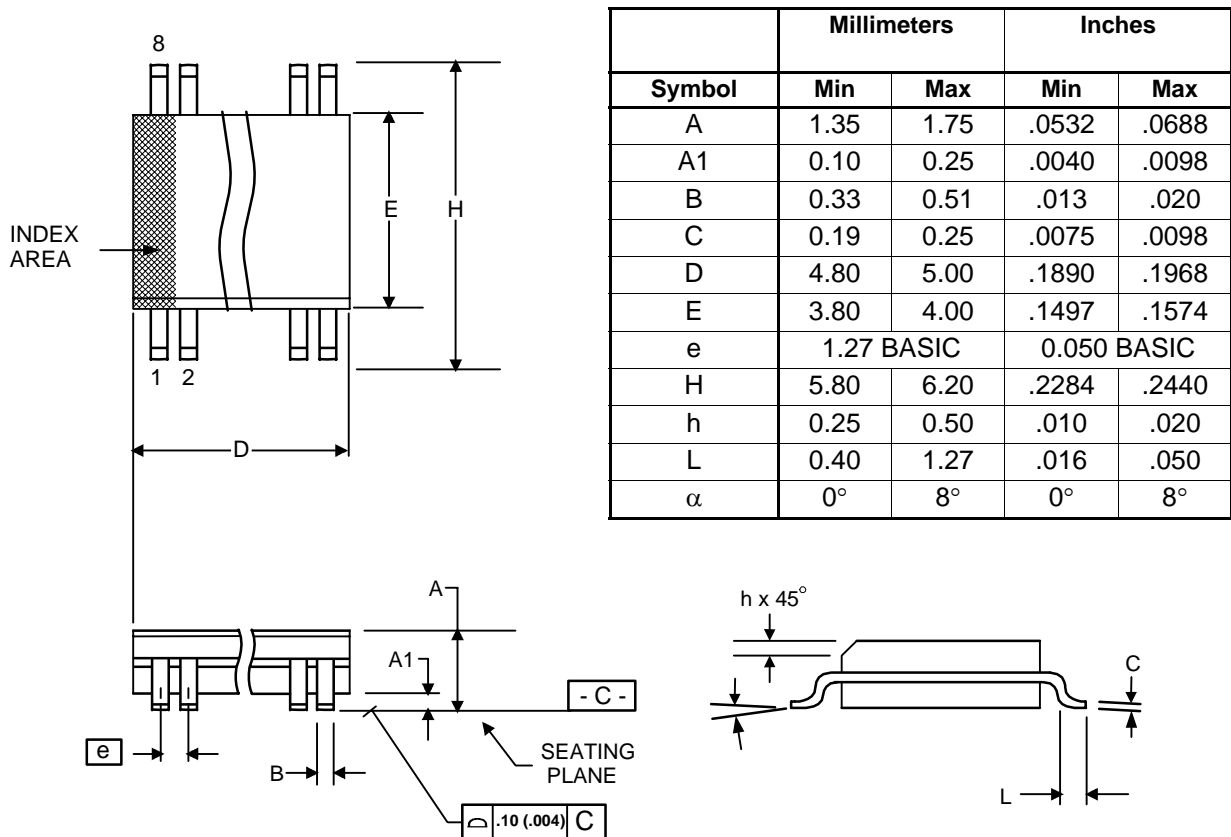

Thermal Characteristics for 8-pin SOIC

Parameter	Symbol	Conditions	Min.	Typ.	Max.	Units
Thermal Resistance Junction to Ambient	θ_{JA}	Still air		150		°C/W
	θ_{JA}	1 m/s air flow		140		°C/W
	θ_{JA}	3 m/s air flow		120		°C/W
Thermal Resistance Junction to Case	θ_{JC}			40		°C/W



Ordering Information

Part / Order Number	Marking	Shipping packaging	Package	Temperature
MK1726-01AG	1726-01AG	Tubes	8-pin TSSOP	0 to +85° C
MK1726-01AGTR	1726-01AG	Tape and Reel	8-pin TSSOP	0 to +85° C
MK1726-01AS	1726-01AS	Tubes	8-pin SOIC	0 to +85° C
MK1726-01ASTR	1726-01AS	Tape and Reel	8-pin SOIC	0 to +85° C
MK1726-02AG	1726-02AG	Tubes	8-pin TSSOP	0 to +85° C
MK1726-02AGTR	1726-02AG	Tape and Reel	8-pin TSSOP	0 to +85° C
MK1726-02AS	1726-02AS	Tubes	8-pin SOIC	0 to +85° C
MK1726-02ASTR	1726-02AS	Tape and Reel	8-pin SOIC	0 to +85° C
MK1726-04AG	1726-04AG	Tubes	8-pin TSSOP	0 to +85° C
MK1726-04AGTR	1726-04AG	Tape and Reel	8-pin TSSOP	0 to +85° C
MK1726-04AS	1726-04AS	Tubes	8-pin SOIC	0 to +85° C
MK1726-04ASTR	1726-04AS	Tape and Reel	8-pin SOIC	0 to +85° C

While the information presented herein has been checked for both accuracy and reliability, Integrated Circuit Systems, Inc. (ICS) assumes no responsibility for either its use or for the infringement of any patents or other rights of third parties, which would result from its use. No other circuits, patents, or licenses are implied. This product is intended for use in normal commercial applications. Any other applications such as those requiring extended temperature range, high reliability, or other extraordinary environmental requirements are not recommended without additional processing by ICS. ICS reserves the right to change any circuitry or specifications without notice. ICS does not authorize or warrant any ICS product for use in life support devices or critical medical instruments.