

54AC/74AC378 • 54ACT/74ACT378

Parallel D Register With Enable

Description

The 'AC/'ACT378 is a 6-bit register with a buffered common Enable. This device is similar to the 'AC/'ACT174, but with common Enable rather than common Master Reset.

- 6-Bit High-Speed Parallel Register
- Positive Edge-Triggered D-Type Inputs
- Fully Buffered Common Clock and Enable inputs
- Outputs Source/Sink 24 mA
- 'ACT378 has TTL-Compatible Inputs

Ordering Code: See Section 6

Logic Symbol

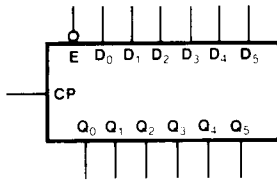

Pin Names

- E Enable Input
- D₀ - D₅ Data Inputs
- CP Clock Pulse Input
- Q₀ - Q₅ Outputs

Connection Diagrams

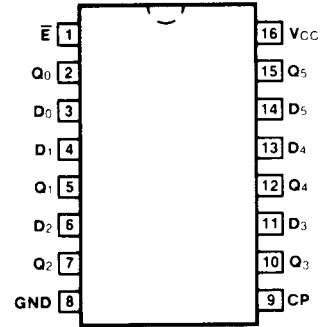

**Pin Assignment
for DIP, Flatpak and SOIC**

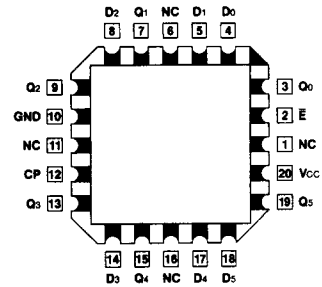

**Pin Assignment
for LCC**

Functional Description

The 'AC/ACT378 consists of six edge-triggered D-type flip-flops with individual D inputs and Q outputs. The Clock (CP) and Enable (\bar{E}) inputs are common to all flip-flops.

When the \bar{E} input is LOW, new data is entered into the register on the LOW-to-HIGH transition of the CP input. When the \bar{E} input is HIGH, the register will retain the present data independent of the CP input.

Truth Table

Inputs			Outputs
\bar{E}	CP	D _n	Q _n
H	┐	X	No Change
L	┐	H	H
L	┐	L	L

H = HIGH Voltage Level
 L = LOW Voltage level
 X = Immaterial
 ┐ = LOW-to-HIGH Transition

Logic Diagram

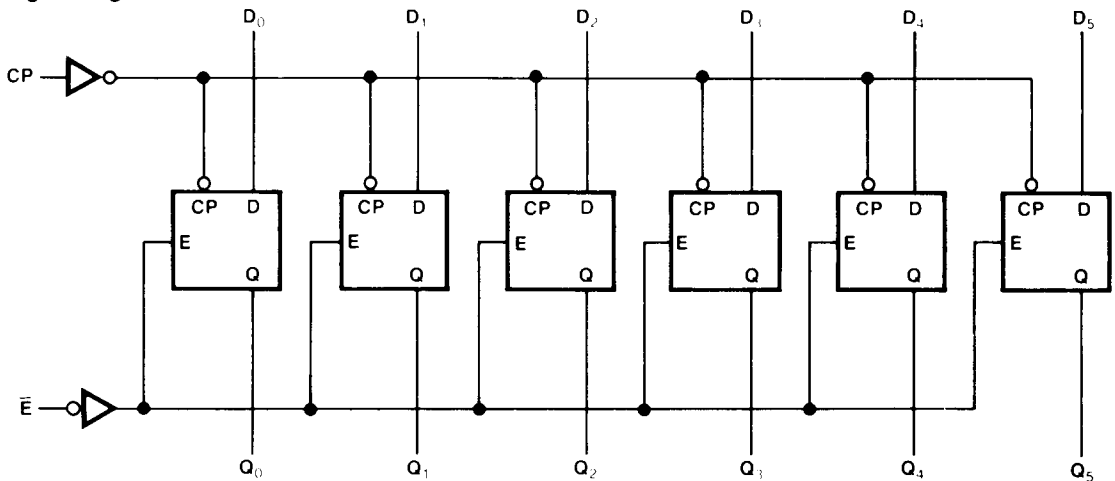

Please note that this diagram is provided only for the understanding of logic operations and should not be used to estimate propagation delays.

DC Characteristics (unless otherwise specified)

Symbol	Parameter	54AC/ACT	74AC/ACT	Units	Conditions
I _{CC}	Maximum Quiescent Supply Current	160	80	μA	V _{IN} = V _{CC} or Ground, V _{CC} = 5.5 V, T _A = Worst Case
I _{CC}	Maximum Quiescent Supply Current	8.0	8.0	μA	V _{IN} = V _{CC} or Ground, V _{CC} = 5.5 V, T _A = 25°
I _{CC(T)}	Maximum Additional I _{CC} /Input (ACT378)	1.6	1.5	mA	V _{IN} = V _{CC} - 2.1 V, V _{CC} = 5.5 V, T _A = Worst Case

AC378 • ACT378

AC Characteristics

Symbol	Parameter	Vcc* (V)	74AC			54AC		74AC		Units	Fig. No.
			TA = +25°C CL = 50 pF			TA = -55°C to +125°C CL = 50 pF		TA = -40°C to +85°C CL = 50 pF			
			Min	Typ	Max	Min	Max	Min	Max		
f _{max}	Maximum Clock Frequency	3.3 5.0	74						MHz	3-3	
t _{PLH}	Propagation Delay CP to Q _n	3.3 5.0	8.5						ns	3-6	
t _{PHL}	Propagation Delay CP to Q _n	3.3 5.0	7.5						ns	3-6	

*Voltage Range 3.3 is 3.3 V ± 0.3 V
Voltage Range 5.0 is 5.0 V ± 0.5 V

AC Operating Requirements

Symbol	Parameter	Vcc* (V)	74AC		54AC		74AC		Units	Fig. No.
			TA = +25°C CL = 50 pF		TA = -55°C to +125°C CL = 50 pF		TA = -40°C to +85°C CL = 50 pF			
			Typ	Guaranteed Minimum						
t _s	Setup Time, HIGH or LOW D _n to CP	3.3 5.0	4.5 3.0						ns	3-9
t _h	Hold Time, HIGH or LOW D _n to CP	3.3 5.0	1.5 1.0						ns	3-9
t _s	Setup Time, HIGH or LOW E to CP	3.3 5.0	-1.5 -1.0						ns	3-9
t _h	Hold Time, HIGH or LOW E to CP	3.3 5.0	0 0						ns	3-9
t _w	CP Pulse Width, HIGH or LOW	3.3 5.0	8.5 6.0						ns	3-6

*Voltage Range 3.3 is 3.3 V ± 0.3 V
Voltage Range 5.0 is 5.0 V ± 0.5 V

Military parameters given herein are for general references only. For current military specifications and subgroup testing information please request Fairchild's Table I data sheet from your Fairchild sales engineer or account representative.

AC Characteristics

Symbol	Parameter	V _{cc} * (V)	74ACT			54ACT		74ACT		Units	Fig. No.
			T _A = +25°C C _L = 50 pF			T _A = -55°C to +125°C C _L = 50 pF		T _A = -40°C to +85°C C _L = 50 pF			
			Min	Typ	Max	Min	Max	Min	Max		
f _{max}	Maximum Clock Frequency	5.0		100					MHz	3-3	
t _{PLH}	Propagation Delay CP to Q _n	5.0		6.0					ns	3-6	
t _{PHL}	Propagation Delay CP to Q _n	5.0		5.5					ns	3-6	

*Voltage Range 5.0 is 5.0 V ± 0.5 V

AC Operating Requirements

Symbol	Parameter	V _{cc} * (V)	74ACT		54ACT		74ACT		Units	Fig. No.
			T _A = +25°C C _L = 50 pF		T _A = -55°C to +125°C C _L = 50 pF		T _A = -40°C to +85°C C _L = 50 pF			
			Typ	Guaranteed Minimum						
t _s	Setup Time, HIGH or LOW D _n to CP	5.0	3.0						ns	3-9
t _h	Hold Time, HIGH or LOW D _n to CP	5.0	1.0						ns	3-9
t _s	Setup Time, HIGH or LOW E to CP	5.0	-1.0						ns	3-9
t _h	Hold Time, HIGH or LOW E to CP	5.0	0						ns	3-9
t _w	CP Pulse Width, HIGH or LOW	5.0	6.0						ns	3-6

*Voltage Range 5.0 is 5.0 V ± 0.5 V

Military parameters given herein are for general references only. For current military specifications and subgroup testing information please request Fairchild's Table I data sheet from your Fairchild sales engineer or account representative.

AC378 • ACT378

Capacitance

Symbol	Parameter	54/74AC/ACT	Units	Conditions
		Typ		
C _{IN}	Input Capacitance	4.5	pF	V _{CC} = 5.5 V
C _{PD}	Power Dissipation Capacitance		pF	V _{CC} = 5.5 V