

MODEL 22

3mm Single Turn Sealed Surface Mount Cermet Trimming Potentiometer

Distributor Item

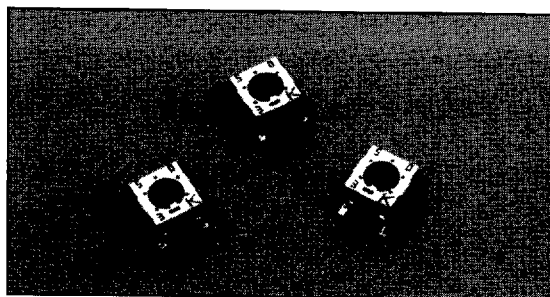

ELECTRICAL

Standard Resistance Range, Ohms	100 to 1Meg
Standard Resistance Tolerance	±20%
Input Voltage, Maximum	200 Vdc or rms not to exceed power rating
Power Rating, Watts	0.125 at 70°C derating to 0 at 125°C
End Resistance, Maximum	1% or 3 Ohms, whichever is greater
Actual Electrical Travel, Nominal	220°
Dielectric Strength	500Vrms
Insulation Resistance, Minimum	100 Megohms
Resolution	Essentially infinite
Contact Resistance Variation, Maximum	3% or 3 Ohms, whichever is greater

ENVIRONMENTAL

Seal	85°C Fluorinert®
Temperature Coefficient, Maximum	±100ppm/°C (<200 ohms = ±250ppm/°C)
Operating Temperature Range	-55°C to +125°C
Thermal Shock	5 cycles, -55°C to +125°C (2% ΔR, 1% ΔVR)
Moisture Resistance	Ten 24 hour cycles (3% ΔR)
Shock, 6ms Sawtooth	100G's (1% ΔR, 1% ΔVR)
Vibration	20G's, 10 to 2,000 Hz (1% ΔR, 1% ΔVR)
High Temperature Exposure	250 hours at 125°C (2% ΔR, 2% ΔVR)
Rotational Life	100 cycles (5% ΔR)
Load Life at 0.25 Watts	1,000 hours at 70°C (3% ΔR, 2% ΔVR)
Resistance to Solder Heat	260°C for 5 sec. (1% ΔRT, 2% ΔVR)

MECHANICAL

Mechanical Stops	Solid
Stop Strength, Minimum	1.3 oz.-in. (100 gr-cm)
Torque, Maximum	.65 oz.-in. (50 gr-cm)
Weight, Nominal	.002 oz. (0.068 grams)

STANDARD RESISTANCE VALUES, OHMS

100	1K	10K	100K	1Meg
200	2K	20K	200K	
500	5K	50K	500K	

Fluorinert® is a registered trademark of 3M Company.
Specifications subject to change without notice.

MODEL 22A - J HOOK

MODEL 22B - GULL WING

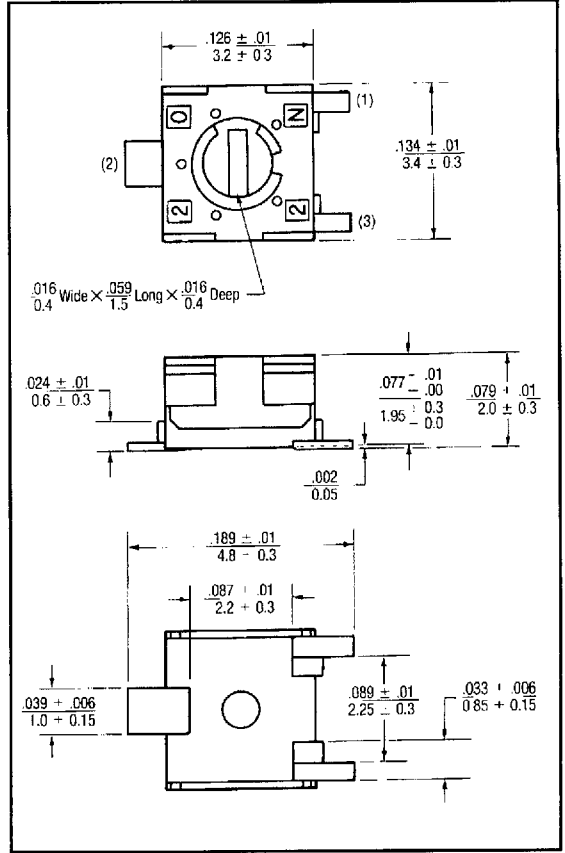
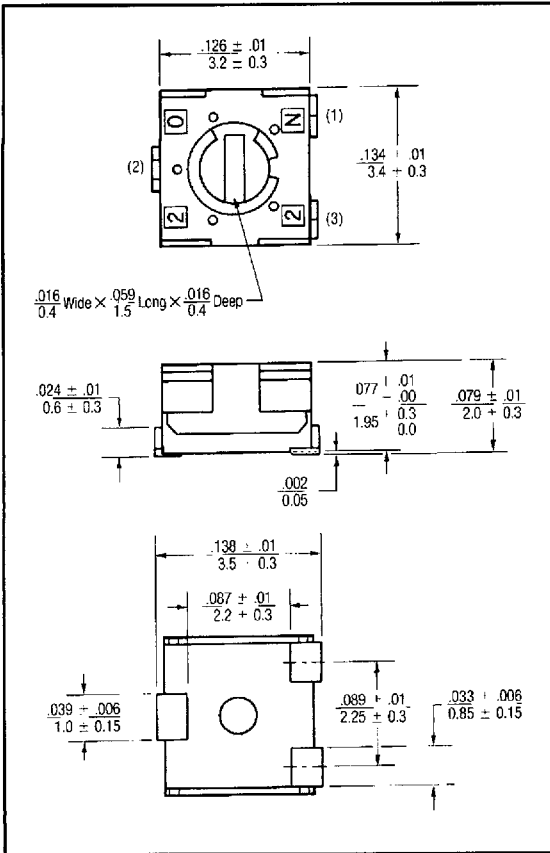

RECOMMENDED PCB LAYOUT

Model 22A

Model 22B

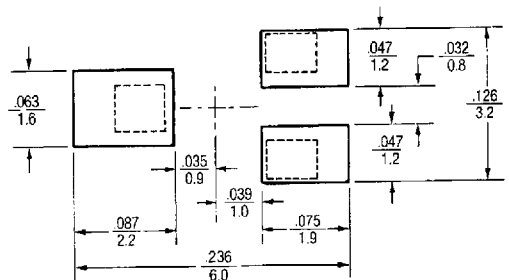
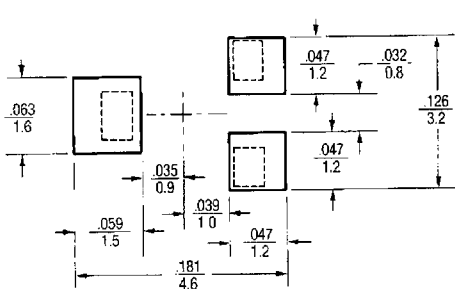

PACKAGING

Standard: Plastic Bags
Capacity = 100 Units

Option: Embossed Tape
All units oriented with #2 (slider) terminal pads adjacent to sprocket holes

Tape	Width	=	12 mm
	Sprocket	=	4 mm Pitch
	Capacity	=	1,000 Units
Reel	Diameter	=	7" (178mm)

ORDERING INFORMATION

Standard:

Model Series ———— **22 A R 10K** ———— Resistance Value
Pin Style ———— ———— Resistance Prefix

Option:

Pin Style ———— **22 A R 10K TR** ———— Packaging Option
TR = Tape & Reel

CIRCUIT DIAGRAM

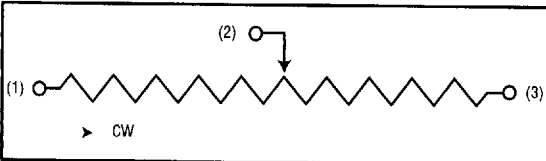

NOTES

English equivalents are based on 1 inch = 25.4mm and are provided for general information only.

Tolerances unless otherwise specified:
Linear = ± 0.3 mm (.01 in.)

