



CYPRESS

PRELIMINARY

CY7C1354C  
CY7C1356C

# 9-Mbit (256K x 36/512K x 18) Pipelined SRAM with NoBL™ Architecture

## Features

- Pin-compatible and functionally equivalent to ZBT™
- Supports 225-MHz bus operations with zero wait states
  - Available speed grades are 225, 200, and 166 MHz
- Internally self-timed output buffer control to eliminate the need to use asynchronous OE
- Fully registered (inputs and outputs) for pipelined operation
- Byte Write capability
- Separate V<sub>DDQ</sub> for 3.3V or 2.5V I/O
- Single 3.3V power supply
- Fast clock-to-output times
  - 2.8 ns (for 225-MHz device)
  - 3.2ns (for 200-MHz device)
  - 3.5 ns (for 166-MHz device)
- Clock Enable ( $\overline{CEN}$ ) pin to suspend operation
- Synchronous self-timed writes
- Available in Lead-Free 100 TQFP, 119 BGA, and 165 fBGA packages
- IEEE 1149.1 JTAG Boundary Scan
- Burst capability—linear or interleaved burst order
- “ZZ” Sleep Mode option and Stop Clock option

## Functional Description

The CY7C1354C and CY7C1356C are 3.3V, 256K x 36 and 512K x 18 Synchronous pipelined burst SRAMs with No Bus Latency™ (NoBL™) logic, respectively. They are designed to support unlimited true back-to-back Read/Write operations with no wait states. The CY7C1354C and CY7C1356C are equipped with the advanced (NoBL) logic required to enable consecutive Read/Write operations with data being transferred on every clock cycle. This feature dramatically improves the throughput of data in systems that require frequent Write/Read transitions. The CY7C1354C and CY7C1356C are pin compatible and functionally equivalent to ZBT devices.

All synchronous inputs pass through input registers controlled by the rising edge of the clock. All data outputs pass through output registers controlled by the rising edge of the clock. The clock input is qualified by the Clock Enable ( $\overline{CEN}$ ) signal, which when deasserted suspends operation and extends the previous clock cycle.

Write operations are controlled by the Byte Write Selects ( $\overline{BW}_a$ – $\overline{BW}_d$  for CY7C1354C and  $\overline{BW}_a$ – $\overline{BW}_b$  for CY7C1356C) and a Write Enable ( $\overline{WE}$ ) input. All writes are conducted with on-chip synchronous self-timed write circuitry.

Three synchronous Chip Enables ( $\overline{CE}_1$ ,  $\overline{CE}_2$ ,  $\overline{CE}_3$ ) and an asynchronous Output Enable ( $\overline{OE}$ ) provide for easy bank selection and output three-state control. In order to avoid bus contention, the output drivers are synchronously three-stated during the data portion of a write sequence.

Logic Block Diagram—CY7C1354C (256K x 36)

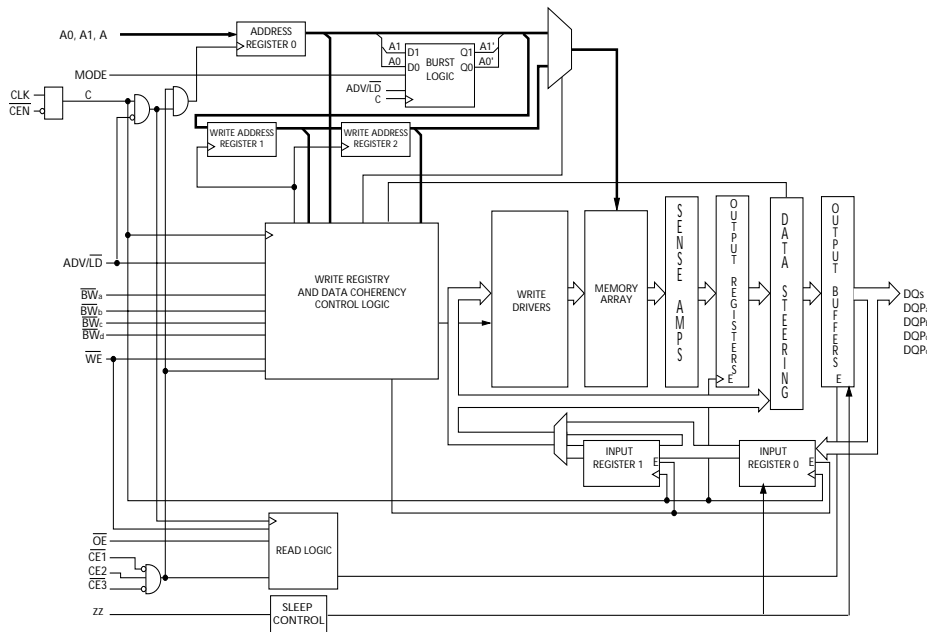

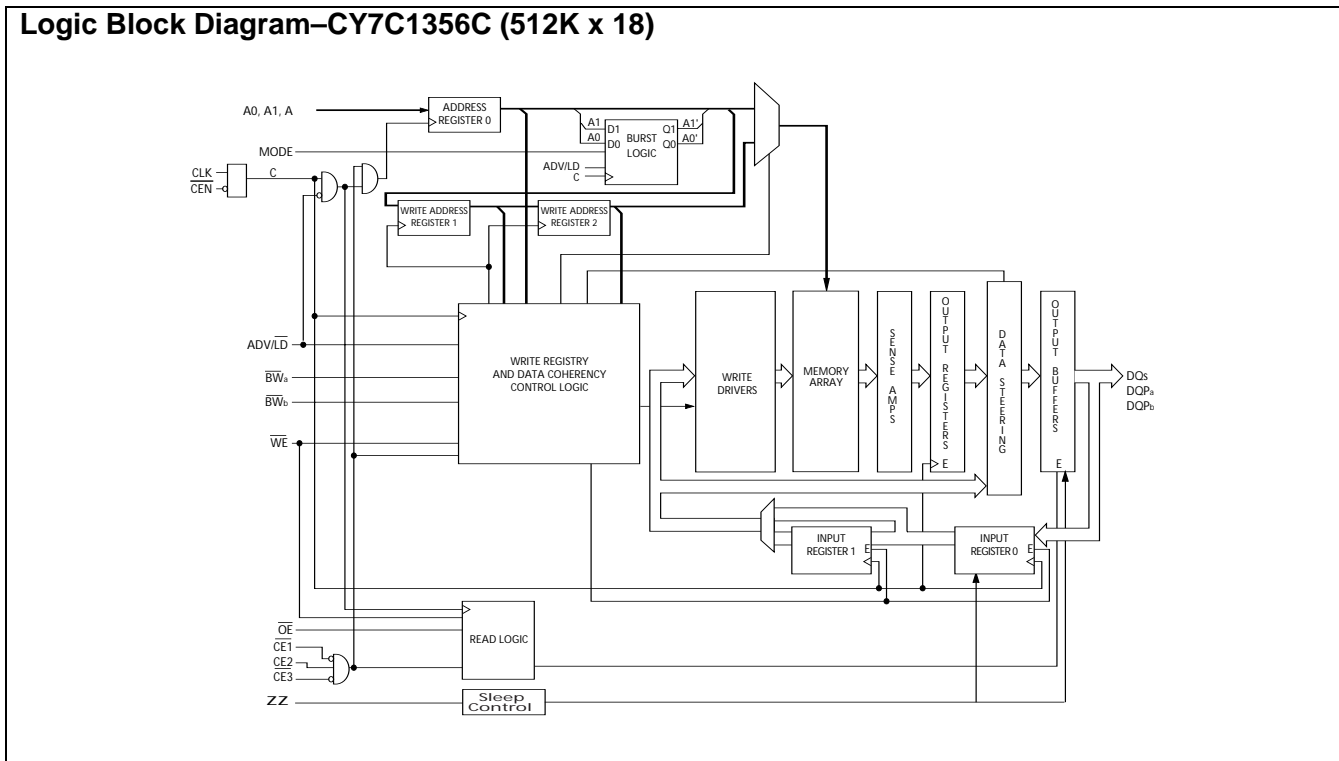
**Logic Block Diagram–CY7C1356C (512K x 18)**

**Selection Guide**

|                              | <b>CY7C1354C-225<br/>CY7C1356C-225</b> | <b>CY7C1354C-200<br/>CY7C1356C-200</b> | <b>CY7C1354C-166<br/>CY7C1356C-166</b> | <b>Unit</b> |
|------------------------------|--|--|--|-------------|
| Maximum Access Time          | 2.8                                    | 3.2                                    | 3.5                                    | ns          |
| Maximum Operating Current    | 250                                    | 220                                    | 180                                    | mA          |
| Maximum CMOS Standby Current | 35                                     | 35                                     | 35                                     | mA          |

Shaded areas contain advance information. Please contact your local Cypress sales representative for availability of these parts.

**Note:**

1. For best-practices recommendations, please refer to the Cypress application note *System Design Guidelines* on [www.cypress.com](http://www.cypress.com).

Pin Configurations

100-pin TQFP Packages

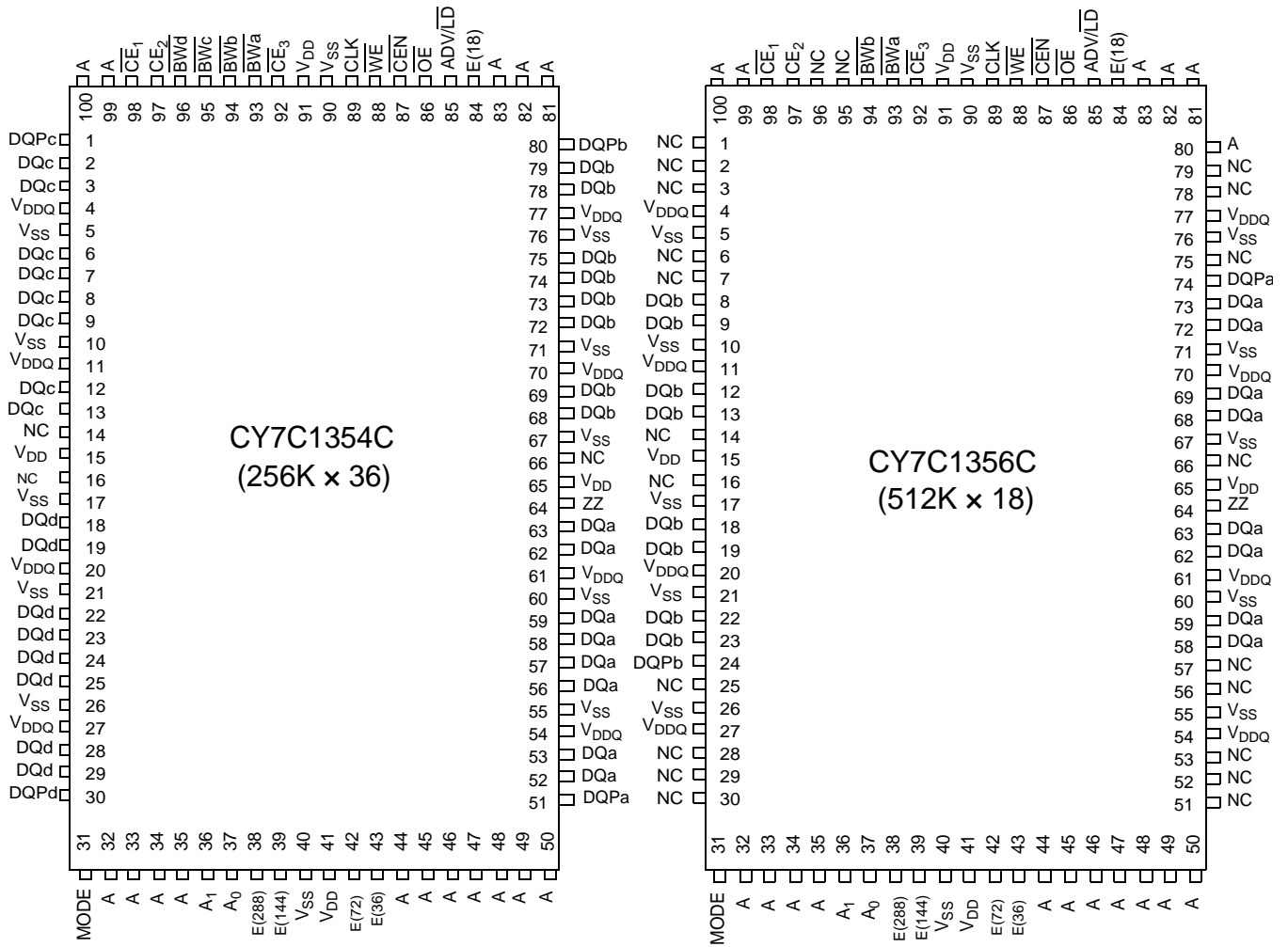

**Pin Configurations (continued)**
**119-ball BGA Pinout  
CY7C1354C (256K x 36) – 14 x 22 BGA**

|          | 1                | 2                | 3               | 4               | 5               | 6                | 7                |
|----------|------------------|------------------|-----------------|-----------------|-----------------|------------------|------------------|
| <b>A</b> | V <sub>DDQ</sub> | A                | A               | E(18)           | A               | A                | V <sub>DDQ</sub> |
| <b>B</b> | NC               | CE <sub>2</sub>  | A               | ADV/LD          | A               | CE <sub>3</sub>  | NC               |
| <b>C</b> | NC               | A                | A               | V <sub>DD</sub> | A               | A                | NC               |
| <b>D</b> | DQ <sub>c</sub>  | DQP <sub>c</sub> | V <sub>SS</sub> | NC              | V <sub>SS</sub> | DQP <sub>b</sub> | DQ <sub>b</sub>  |
| <b>E</b> | DQ <sub>c</sub>  | DQ <sub>c</sub>  | V <sub>SS</sub> | CE <sub>1</sub> | V <sub>SS</sub> | DQ <sub>b</sub>  | DQ <sub>b</sub>  |
| <b>F</b> | V <sub>DDQ</sub> | DQ <sub>c</sub>  | V <sub>SS</sub> | OE              | V <sub>SS</sub> | DQ <sub>b</sub>  | V <sub>DDQ</sub> |
| <b>G</b> | DQ <sub>c</sub>  | DQ <sub>c</sub>  | BW <sub>c</sub> | A               | BW <sub>b</sub> | DQ <sub>b</sub>  | DQ <sub>b</sub>  |
| <b>H</b> | DQ <sub>c</sub>  | DQ <sub>c</sub>  | V <sub>SS</sub> | WE              | V <sub>SS</sub> | DQ <sub>b</sub>  | DQ <sub>b</sub>  |
| <b>J</b> | V <sub>DDQ</sub> | V <sub>DD</sub>  | NC              | V <sub>DD</sub> | NC              | V <sub>DD</sub>  | V <sub>DDQ</sub> |
| <b>K</b> | DQ <sub>d</sub>  | DQ <sub>d</sub>  | V <sub>SS</sub> | CLK             | V <sub>SS</sub> | DQ <sub>a</sub>  | DQ <sub>a</sub>  |
| <b>L</b> | DQ <sub>d</sub>  | DQ <sub>d</sub>  | BW <sub>d</sub> | NC              | BW <sub>a</sub> | DQ <sub>a</sub>  | DQ <sub>a</sub>  |
| <b>M</b> | V <sub>DDQ</sub> | DQ <sub>d</sub>  | V <sub>SS</sub> | CEN             | V <sub>SS</sub> | DQ <sub>a</sub>  | V <sub>DDQ</sub> |
| <b>N</b> | DQ <sub>d</sub>  | DQ <sub>d</sub>  | V <sub>SS</sub> | A1              | V <sub>SS</sub> | DQ <sub>a</sub>  | DQ <sub>a</sub>  |
| <b>P</b> | DQ <sub>d</sub>  | DQP <sub>d</sub> | V <sub>SS</sub> | A0              | V <sub>SS</sub> | DQP <sub>a</sub> | DQ <sub>a</sub>  |
| <b>R</b> | NC               | A                | MODE            | V <sub>DD</sub> | NC              | A                | NC               |
| <b>T</b> | NC               | E(72)            | A               | A               | A               | E(36)            | ZZ               |
| <b>U</b> | V <sub>DDQ</sub> | TMS              | TDI             | TCK             | TDO             | NC               | V <sub>DDQ</sub> |

**CY7C1356C (512K x 18)–14 x 22 BGA**

|          | 1                | 2                | 3               | 4               | 5               | 6                | 7                |
|----------|------------------|------------------|-----------------|-----------------|-----------------|------------------|------------------|
| <b>A</b> | V <sub>DDQ</sub> | A                | A               | E(18)           | A               | A                | V <sub>DDQ</sub> |
| <b>B</b> | NC               | CE <sub>2</sub>  | A               | ADV/LD          | A               | CE <sub>3</sub>  | NC               |
| <b>C</b> | NC               | A                | A               | V <sub>DD</sub> | A               | A                | NC               |
| <b>D</b> | DQ <sub>b</sub>  | NC               | V <sub>SS</sub> | NC              | V <sub>SS</sub> | DQP <sub>a</sub> | NC               |
| <b>E</b> | NC               | DQ <sub>b</sub>  | V <sub>SS</sub> | CE <sub>1</sub> | V <sub>SS</sub> | NC               | DQ <sub>a</sub>  |
| <b>F</b> | V <sub>DDQ</sub> | NC               | V <sub>SS</sub> | OE              | V <sub>SS</sub> | DQ <sub>a</sub>  | V <sub>DDQ</sub> |
| <b>G</b> | NC               | DQ <sub>b</sub>  | BW <sub>b</sub> | A               | V <sub>SS</sub> | NC               | DQ <sub>a</sub>  |
| <b>H</b> | DQ <sub>b</sub>  | NC               | V <sub>SS</sub> | WE              | V <sub>SS</sub> | DQ <sub>a</sub>  | NC               |
| <b>J</b> | V <sub>DDQ</sub> | V <sub>DD</sub>  | NC              | V <sub>DD</sub> | NC              | V <sub>DD</sub>  | V <sub>DDQ</sub> |
| <b>K</b> | NC               | DQ <sub>b</sub>  | V <sub>SS</sub> | CLK             | V <sub>SS</sub> | NC               | DQ <sub>a</sub>  |
| <b>L</b> | DQ <sub>b</sub>  | NC               | V <sub>SS</sub> | NC              | BW <sub>a</sub> | DQ <sub>a</sub>  | NC               |
| <b>M</b> | V <sub>DDQ</sub> | DQ <sub>b</sub>  | V <sub>SS</sub> | CEN             | V <sub>SS</sub> | NC               | V <sub>DDQ</sub> |
| <b>N</b> | DQ <sub>b</sub>  | NC               | V <sub>SS</sub> | A1              | V <sub>SS</sub> | DQ <sub>a</sub>  | NC               |
| <b>P</b> | NC               | DQP <sub>b</sub> | V <sub>SS</sub> | A0              | V <sub>SS</sub> | NC               | DQ <sub>a</sub>  |
| <b>R</b> | NC               | A                | MODE            | V <sub>DD</sub> | NC              | A                | NC               |
| <b>T</b> | E(72)            | A                | A               | E(36)           | A               | A                | ZZ               |
| <b>U</b> | V <sub>DDQ</sub> | TMS              | TDI             | TCK             | TDO             | NC               | V <sub>DDQ</sub> |



Pin Configurations (continued)

165-Ball fBGA Pinout

CY7C1354C (256K x 36) – 13 x 15 fBGA

|          | 1                | 2               | 3                 | 4                 | 5                 | 6                 | 7                | 8               | 9                | 10              | 11               |
|----------|------------------|-----------------|-------------------|-------------------|-------------------|-------------------|------------------|-----------------|------------------|-----------------|------------------|
| <b>A</b> | E(288)           | A               | $\overline{CE}_1$ | $\overline{BW}_c$ | $\overline{BW}_b$ | $\overline{CE}_3$ | $\overline{CEN}$ | ADV/LD          | A                | A               | NC               |
| <b>B</b> | NC               | A               | CE2               | $\overline{BW}_d$ | $\overline{BW}_a$ | CLK               | $\overline{WE}$  | $\overline{OE}$ | E(18)            | A               | E(144)           |
| <b>C</b> | DQP <sub>c</sub> | NC              | V <sub>DDQ</sub>  | V <sub>SS</sub>   | V <sub>SS</sub>   | V <sub>SS</sub>   | V <sub>SS</sub>  | V <sub>SS</sub> | V <sub>DDQ</sub> | NC              | DQP <sub>b</sub> |
| <b>D</b> | DQ <sub>c</sub>  | DQ <sub>c</sub> | V <sub>DDQ</sub>  | V <sub>DD</sub>   | V <sub>SS</sub>   | V <sub>SS</sub>   | V <sub>SS</sub>  | V <sub>DD</sub> | V <sub>DDQ</sub> | DQ <sub>b</sub> | DQ <sub>b</sub>  |
| <b>E</b> | DQ <sub>c</sub>  | DQ <sub>c</sub> | V <sub>DDQ</sub>  | V <sub>DD</sub>   | V <sub>SS</sub>   | V <sub>SS</sub>   | V <sub>SS</sub>  | V <sub>DD</sub> | V <sub>DDQ</sub> | DQ <sub>b</sub> | DQ <sub>b</sub>  |
| <b>F</b> | DQ <sub>c</sub>  | DQ <sub>c</sub> | V <sub>DDQ</sub>  | V <sub>DD</sub>   | V <sub>SS</sub>   | V <sub>SS</sub>   | V <sub>SS</sub>  | V <sub>DD</sub> | V <sub>DDQ</sub> | DQ <sub>b</sub> | DQ <sub>b</sub>  |
| <b>G</b> | DQ <sub>c</sub>  | DQ <sub>c</sub> | V <sub>DDQ</sub>  | V <sub>DD</sub>   | V <sub>SS</sub>   | V <sub>SS</sub>   | V <sub>SS</sub>  | V <sub>DD</sub> | V <sub>DDQ</sub> | DQ <sub>b</sub> | DQ <sub>b</sub>  |
| <b>H</b> | NC               | NC              | NC                | V <sub>DD</sub>   | V <sub>SS</sub>   | V <sub>SS</sub>   | V <sub>SS</sub>  | V <sub>DD</sub> | NC               | NC              | ZZ               |
| <b>J</b> | DQ <sub>d</sub>  | DQ <sub>d</sub> | V <sub>DDQ</sub>  | V <sub>DD</sub>   | V <sub>SS</sub>   | V <sub>SS</sub>   | V <sub>SS</sub>  | V <sub>DD</sub> | V <sub>DDQ</sub> | DQ <sub>a</sub> | DQ <sub>a</sub>  |
| <b>K</b> | DQ <sub>d</sub>  | DQ <sub>d</sub> | V <sub>DDQ</sub>  | V <sub>DD</sub>   | V <sub>SS</sub>   | V <sub>SS</sub>   | V <sub>SS</sub>  | V <sub>DD</sub> | V <sub>DDQ</sub> | DQ <sub>a</sub> | DQ <sub>a</sub>  |
| <b>L</b> | DQ <sub>d</sub>  | DQ <sub>d</sub> | V <sub>DDQ</sub>  | V <sub>DD</sub>   | V <sub>SS</sub>   | V <sub>SS</sub>   | V <sub>SS</sub>  | V <sub>DD</sub> | V <sub>DDQ</sub> | DQ <sub>a</sub> | DQ <sub>a</sub>  |
| <b>M</b> | DQ <sub>d</sub>  | DQ <sub>d</sub> | V <sub>DDQ</sub>  | V <sub>DD</sub>   | V <sub>SS</sub>   | V <sub>SS</sub>   | V <sub>SS</sub>  | V <sub>DD</sub> | V <sub>DDQ</sub> | DQ <sub>a</sub> | DQ <sub>a</sub>  |
| <b>N</b> | DQP <sub>d</sub> | NC              | V <sub>DDQ</sub>  | V <sub>SS</sub>   | NC                | NC                | NC               | V <sub>SS</sub> | V <sub>DDQ</sub> | NC              | DQP <sub>a</sub> |
| <b>P</b> | NC               | E(72)           | A                 | A                 | TDI               | A1                | TDO              | A               | A                | A               | NC               |
| <b>R</b> | MODE             | E(36)           | A                 | A                 | TMS               | A0                | TCK              | A               | A                | A               | A                |

CY7C1356C (512K x 18) – 13 x 15 fBGA

|          | 1                | 2               | 3                 | 4                 | 5                 | 6                 | 7                | 8               | 9                | 10              | 11               |
|----------|------------------|-----------------|-------------------|-------------------|-------------------|-------------------|------------------|-----------------|------------------|-----------------|------------------|
| <b>A</b> | E(288)           | A               | $\overline{CE}_1$ | $\overline{BW}_b$ | NC                | $\overline{CE}_3$ | $\overline{CEN}$ | ADV/LD          | A                | A               | A                |
| <b>B</b> | NC               | A               | CE2               | NC                | $\overline{BW}_a$ | CLK               | $\overline{WE}$  | $\overline{OE}$ | E(18)            | A               | E(144)           |
| <b>C</b> | NC               | NC              | V <sub>DDQ</sub>  | V <sub>SS</sub>   | V <sub>SS</sub>   | V <sub>SS</sub>   | V <sub>SS</sub>  | V <sub>SS</sub> | V <sub>DDQ</sub> | NC              | DQP <sub>a</sub> |
| <b>D</b> | NC               | DQ <sub>b</sub> | V <sub>DDQ</sub>  | V <sub>DD</sub>   | V <sub>SS</sub>   | V <sub>SS</sub>   | V <sub>SS</sub>  | V <sub>DD</sub> | V <sub>DDQ</sub> | NC              | DQ <sub>a</sub>  |
| <b>E</b> | NC               | DQ <sub>b</sub> | V <sub>DDQ</sub>  | V <sub>DD</sub>   | V <sub>SS</sub>   | V <sub>SS</sub>   | V <sub>SS</sub>  | V <sub>DD</sub> | V <sub>DDQ</sub> | NC              | DQ <sub>a</sub>  |
| <b>F</b> | NC               | DQ <sub>b</sub> | V <sub>DDQ</sub>  | V <sub>DD</sub>   | V <sub>SS</sub>   | V <sub>SS</sub>   | V <sub>SS</sub>  | V <sub>DD</sub> | V <sub>DDQ</sub> | NC              | DQ <sub>a</sub>  |
| <b>G</b> | NC               | DQ <sub>b</sub> | V <sub>DDQ</sub>  | V <sub>DD</sub>   | V <sub>SS</sub>   | V <sub>SS</sub>   | V <sub>SS</sub>  | V <sub>DD</sub> | V <sub>DDQ</sub> | NC              | DQ <sub>a</sub>  |
| <b>H</b> | NC               | NC              | NC                | V <sub>DD</sub>   | V <sub>SS</sub>   | V <sub>SS</sub>   | V <sub>SS</sub>  | V <sub>DD</sub> | NC               | NC              | ZZ               |
| <b>J</b> | DQ <sub>b</sub>  | NC              | V <sub>DDQ</sub>  | V <sub>DD</sub>   | V <sub>SS</sub>   | V <sub>SS</sub>   | V <sub>SS</sub>  | V <sub>DD</sub> | V <sub>DDQ</sub> | DQ <sub>a</sub> | NC               |
| <b>K</b> | DQ <sub>b</sub>  | NC              | V <sub>DDQ</sub>  | V <sub>DD</sub>   | V <sub>SS</sub>   | V <sub>SS</sub>   | V <sub>SS</sub>  | V <sub>DD</sub> | V <sub>DDQ</sub> | DQ <sub>a</sub> | NC               |
| <b>L</b> | DQ <sub>b</sub>  | NC              | V <sub>DDQ</sub>  | V <sub>DD</sub>   | V <sub>SS</sub>   | V <sub>SS</sub>   | V <sub>SS</sub>  | V <sub>DD</sub> | V <sub>DDQ</sub> | DQ <sub>a</sub> | NC               |
| <b>M</b> | DQ <sub>b</sub>  | NC              | V <sub>DDQ</sub>  | V <sub>DD</sub>   | V <sub>SS</sub>   | V <sub>SS</sub>   | V <sub>SS</sub>  | V <sub>DD</sub> | V <sub>DDQ</sub> | DQ <sub>a</sub> | NC               |
| <b>N</b> | DQP <sub>b</sub> | NC              | V <sub>DDQ</sub>  | V <sub>SS</sub>   | NC                | NC                | NC               | V <sub>SS</sub> | V <sub>DDQ</sub> | NC              | NC               |
| <b>P</b> | NC               | E(72)           | A                 | A                 | TDI               | A1                | TDO              | A               | A                | A               | NC               |
| <b>R</b> | MODE             | E(36)           | A                 | A                 | TMS               | A0                | TCK              | A               | A                | A               | A                |

**Pin Definitions**

| Pin Name   | I/O Type                       | Pin Description  |
|--|--------------------------------|--|
| A0<br>A1<br>A  | Input-Synchronous              | <b>Address Inputs used to select one of the address locations.</b> Sampled at the rising edge of the CLK.  |
| BW <sub>a</sub> ,<br>BW <sub>b</sub> ,<br>BW <sub>c</sub> ,<br>BW <sub>d</sub> | Input-Synchronous              | <b>Byte Write Select Inputs, active LOW.</b> Qualified with WE to conduct writes to the SRAM. Sampled on the rising edge of CLK. BW <sub>a</sub> controls DQ <sub>a</sub> and DQP <sub>a</sub> , BW <sub>b</sub> controls DQ <sub>b</sub> and DQP <sub>b</sub> , BW <sub>c</sub> controls DQ <sub>c</sub> and DQP <sub>c</sub> , BW <sub>d</sub> controls DQ <sub>d</sub> and DQP <sub>d</sub> .   |
| WE   | Input-Synchronous              | <b>Write Enable Input, active LOW.</b> Sampled on the rising edge of CLK if CEN is active LOW. This signal must be asserted LOW to initiate a write sequence.  |
| ADV/LD   | Input-Synchronous              | <b>Advance/Load Input used to advance the on-chip address counter or load a new address.</b> When HIGH (and CEN is asserted LOW) the internal burst counter is advanced. When LOW, a new address can be loaded into the device for an access. After being deselected, ADV/LD should be driven LOW in order to load a new address.  |
| CLK  | Input-Clock                    | <b>Clock Input.</b> Used to capture all synchronous inputs to the device. CLK is qualified with CEN. CLK is only recognized if CEN is active LOW.  |
| $\overline{CE}_1$  | Input-Synchronous              | <b>Chip Enable 1 Input, active LOW.</b> Sampled on the rising edge of CLK. Used in conjunction with CE <sub>2</sub> and CE <sub>3</sub> to select/deselect the device.   |
| CE <sub>2</sub>  | Input-Synchronous              | <b>Chip Enable 2 Input, active HIGH.</b> Sampled on the rising edge of CLK. Used in conjunction with CE <sub>1</sub> and CE <sub>3</sub> to select/deselect the device.  |
| $\overline{CE}_3$  | Input-Synchronous              | <b>Chip Enable 3 Input, active LOW.</b> Sampled on the rising edge of CLK. Used in conjunction with CE <sub>1</sub> and CE <sub>2</sub> to select/deselect the device.   |
| $\overline{OE}$  | Input-Asynchronous             | <b>Output Enable, active LOW.</b> Combined with the synchronous logic block inside the device to control the direction of the I/O pins. When LOW, the I/O pins are allowed to behave as outputs. When deasserted HIGH, I/O pins are three-stated, and act as input data pins. OE is masked during the data portion of a Write sequence, during the first clock when emerging from a deselected state and when the device has been deselected.  |
| $\overline{CEN}$   | Input-Synchronous              | <b>Clock Enable Input, active LOW.</b> When asserted LOW the clock signal is recognized by the SRAM. When deasserted HIGH the clock signal is masked. Since deasserting CEN does not deselect the device, CEN can be used to extend the previous cycle when required.  |
| DQ <sub>s</sub>  | I/O-Synchronous                | <b>Bidirectional Data I/O lines.</b> As inputs, they feed into an on-chip data register that is triggered by the rising edge of CLK. As outputs, they deliver the data contained in the memory location specified by addresses during the previous clock rise of the Read cycle. The direction of the pins is controlled by OE and the internal control logic. When OE is asserted LOW, the pins can behave as outputs. When HIGH, DQ <sub>a</sub> –DQ <sub>d</sub> are placed in a three-state condition. The outputs are automatically three-stated during the data portion of a write sequence, during the first clock when emerging from a deselected state, and when the device is deselected, regardless of the state of OE. |
| DQP <sub>x</sub>   | I/O-Synchronous                | <b>Bidirectional Data Parity I/O lines.</b> Functionally, these signals are identical to DQ <sub>[a:d]</sub> . During write sequences, DQP <sub>a</sub> is controlled by BW <sub>a</sub> , DQP <sub>b</sub> is controlled by BW <sub>b</sub> , DQP <sub>c</sub> is controlled by BW <sub>c</sub> , and DQP <sub>d</sub> is controlled by BW <sub>d</sub> .   |
| MODE   | Input Strap Pin                | <b>Mode Input.</b> Selects the burst order of the device. Tied HIGH selects the interleaved burst order. Pulled LOW selects the linear burst order. MODE should not change states during operation. When left floating MODE will default HIGH, to an interleaved burst order.  |
| TDO  | JTAG serial output Synchronous | <b>Serial data-out to the JTAG circuit.</b> Delivers data on the negative edge of TCK.   |
| TDI  | JTAG serial input Synchronous  | <b>Serial data-In to the JTAG circuit.</b> Sampled on the rising edge of TCK.  |
| TMS  | Test Mode Select Synchronous   | <b>This pin controls the Test Access Port state machine.</b> Sampled on the rising edge of TCK.  |
| TCK  | JTAG-Clock                     | <b>Clock input to the JTAG circuitry.</b>  |
| V <sub>DD</sub>  | Power Supply                   | <b>Power supply inputs to the core of the device.</b>  |
| V <sub>DDQ</sub>   | I/O Power Supply               | <b>Power supply for the I/O circuitry.</b>   |
| V <sub>SS</sub>  | Ground                         | <b>Ground for the device.</b> Should be connected to ground of the system.   |

**Pin Definitions** (continued)

| Pin Name            | I/O Type           | Pin Description  |
|---------------------|--------------------|--|
| NC                  | –                  | <b>No connects.</b> This pin is not connected to the die.  |
| E(18,36,72,144,288) | –                  | <b>These pins are not connected.</b> They will be used for expansion to the 18M, 36M, 72M, 144M and 288M densities.  |
| ZZ                  | Input-Asynchronous | <b>ZZ “sleep” Input.</b> This active HIGH input places the device in a non-time-critical “sleep” condition with data integrity preserved. During normal operation, this pin can be connected to $V_{SS}$ or left floating. |

**Functional Overview**

The CY7C1354C and CY7C1356C are synchronous-pipelined Burst NoBL SRAMs designed specifically to eliminate wait states during Write/Read transitions. All synchronous inputs pass through input registers controlled by the rising edge of the clock. The clock signal is qualified with the Clock Enable input signal (CEN). If CEN is HIGH, the clock signal is not recognized and all internal states are maintained. All synchronous operations are qualified with  $\overline{CEN}$ . All data outputs pass through output registers controlled by the rising edge of the clock. Maximum access delay from the clock rise ( $t_{CO}$ ) is 2.8 ns (225-MHz device).

Accesses can be initiated by asserting all three Chip Enables ( $\overline{CE}_1, \overline{CE}_2, \overline{CE}_3$ ) active at the rising edge of the clock. If Clock Enable (CEN) is active LOW and ADV/LD is asserted LOW, the address presented to the device will be latched. The access can either be a Read or Write operation, depending on the status of the Write Enable (WE).  $BW_{[d:a]}$  can be used to conduct Byte Write operations.

Write operations are qualified by the Write Enable ( $\overline{WE}$ ). All Writes are simplified with on-chip synchronous self-timed Write circuitry.

Three synchronous Chip Enables ( $\overline{CE}_1, \overline{CE}_2, \overline{CE}_3$ ) and an asynchronous Output Enable ( $\overline{OE}$ ) simplify depth expansion. All operations (Reads, Writes, and Deselects) are pipelined. ADV/LD should be driven LOW once the device has been deselected in order to load a new address for the next operation.

**Single Read Accesses**

A read access is initiated when the following conditions are satisfied at clock rise: (1) CEN is asserted LOW, (2)  $\overline{CE}_1, \overline{CE}_2,$  and  $\overline{CE}_3$  are ALL asserted active, (3) the Write Enable input signal WE is deasserted HIGH, and (4) ADV/LD is asserted LOW. The address presented to the address inputs is latched into the address register and presented to the memory core and control logic. The control logic determines that a read access is in progress and allows the requested data to propagate to the input of the output register. At the rising edge of the next clock the requested data is allowed to propagate through the output register and onto the data bus within 2.8 ns (225-MHz device) provided OE is active LOW. After the first clock of the read access the output buffers are controlled by OE and the internal control logic. OE must be driven LOW in order for the device to drive out the requested data. During the second clock, a subsequent operation (Read/Write/Deselect) can be initiated. Deselecting the device is also pipelined. Therefore, when the SRAM is deselected at clock rise by one of the chip enable signals, its output will three-state following the next clock rise.

**Burst Read Accesses**

The CY7C1354C and CY7C1356C have an on-chip burst counter that allows the user the ability to supply a single address and conduct up to four Reads without reasserting the address inputs. ADV/LD must be driven LOW in order to load a new address into the SRAM, as described in the Single Read Access section above. The sequence of the burst counter is determined by the MODE input signal. A LOW input on MODE selects a linear burst mode, a HIGH selects an interleaved burst sequence. Both burst counters use A0 and A1 in the burst sequence, and will wrap around when incremented sufficiently. A HIGH input on ADV/LD will increment the internal burst counter regardless of the state of chip enables inputs or WE. WE is latched at the beginning of a burst cycle. Therefore, the type of access (Read or Write) is maintained throughout the burst sequence.

**Single Write Accesses**

Write access are initiated when the following conditions are satisfied at clock rise: (1) CEN is asserted LOW, (2)  $\overline{CE}_1, \overline{CE}_2,$  and  $\overline{CE}_3$  are ALL asserted active, and (3) the Write signal WE is asserted LOW. The address presented to  $A_0 \angle A_{16}$  is loaded into the Address Register. The write signals are latched into the Control Logic block.

On the subsequent clock rise the data lines are automatically three-stated regardless of the state of the OE input signal. This allows the external logic to present the data on DQ and DQP ( $DQ_{a,b,c,d}/DQP_{a,b,c,d}$  for CY7C1354C and  $DQ_{a,b}/DQP_{a,b}$  for CY7C1356C). In addition, the address for the subsequent access (Read/Write/Deselect) is latched into the address register (provided the appropriate control signals are asserted).

On the next clock rise the data presented to DQ and DQP ( $DQ_{a,b,c,d}/DQP_{a,b,c,d}$  for CY7C1354C and  $DQ_{a,b}/DQP_{a,b}$  for CY7C1356C) (or a subset for byte write operations, see Write Cycle Description table for details) inputs is latched into the device and the Write is complete.

The data written during the Write operation is controlled by BW ( $BW_{a,b,c,d}$  for CY7C1354C and  $BW_{a,b}$  for CY7C1356C) signals. The CY7C1354C/56C provides Byte Write capability that is described in the Write Cycle Description table. Asserting the Write Enable input (WE) with the selected Byte Write Select (BW) input will selectively write to only the desired bytes. Bytes not selected during a Byte Write operation will remain unaltered. A synchronous self-timed write mechanism has been provided to simplify the Write operations. Byte Write capability has been included in order to greatly simplify Read/Modify/Write sequences, which can be reduced to simple Byte Write operations.

Because the CY7C1354C and CY7C1356C are common I/O devices, data should not be driven into the device while the outputs are active. The Output Enable (OE) can be deasserted

HIGH before presenting data to the DQ and DQP (DQ<sub>a,b,c,d</sub>/DQP<sub>a,b,c,d</sub> for CY7C1354C and DQ<sub>a,b</sub>/DQP<sub>a,b</sub> for CY7C1356C) inputs. Doing so will three-state the output drivers. As a safety precaution, DQ and DQP (DQ<sub>a,b,c,d</sub>/DQP<sub>a,b,c,d</sub> for CY7C1354C and DQ<sub>a,b</sub>/DQP<sub>a,b</sub> for CY7C1356C) are automatically three-stated during the data portion of a write cycle, regardless of the state of OE.

### Burst Write Accesses

The CY7C1354C/56C has an on-chip burst counter that allows the user the ability to supply a single address and conduct up to four WRITE operations without reasserting the address inputs. ADV/LD must be driven LOW in order to load the initial address, as described in the Single Write Access section above. When ADV/LD is driven HIGH on the subsequent clock rise, the chip enables (CE<sub>1</sub>, CE<sub>2</sub>, and CE<sub>3</sub>) and WE inputs are ignored and the burst counter is incremented. The correct BW (BW<sub>a,b,c,d</sub> for CY7C1354C and BW<sub>a,b</sub> for CY7C1356C) inputs must be driven in each cycle of the burst write in order to write the correct bytes of data.

### Sleep Mode

The ZZ input pin is an asynchronous input. Asserting ZZ places the SRAM in a power conservation “sleep” mode. Two clock cycles are required to enter into or exit from this “sleep” mode. While in this mode, data integrity is guaranteed.

### ZZ Mode Electrical Characteristics

| Parameter          | Description                       | Test Conditions             | Min.              | Max               | Unit |
|--------------------|-----------------------------------|-----------------------------|-------------------|-------------------|------|
| I <sub>DDZZ</sub>  | Sleep mode standby current        | ZZ ≥ V <sub>DD</sub> - 0.2V |                   | 50                | mA   |
| t <sub>ZZS</sub>   | Device operation to ZZ            | ZZ ≥ V <sub>DD</sub> - 0.2V |                   | 2t <sub>CYC</sub> | ns   |
| t <sub>ZZREC</sub> | ZZ recovery time                  | ZZ ≤ 0.2V                   | 2t <sub>CYC</sub> |                   | ns   |
| t <sub>ZZI</sub>   | ZZ active to sleep current        | This parameter is sampled   |                   | 2t <sub>CYC</sub> | ns   |
| t <sub>RZZI</sub>  | ZZ Inactive to exit sleep current | This parameter is sampled   | 0                 |                   | ns   |

### Truth Table<sup>[2, 3, 4, 5, 6, 7, 8]</sup>

| Operation                     | Address Used | CE | ZZ | ADV/LD | WE | BW <sub>x</sub> | OE | CEN | CLK | DQ           |
|-------------------------------|--------------|----|----|--------|----|-----------------|----|-----|-----|--------------|
| Deselect Cycle                | None         | H  | L  | L      | X  | X               | X  | L   | L-H | Three-State  |
| Continue Deselect Cycle       | None         | X  | L  | H      | X  | X               | X  | L   | L-H | Three-State  |
| Read Cycle (Begin Burst)      | External     | L  | L  | L      | H  | X               | L  | L   | L-H | Data Out (Q) |
| Read Cycle (Continue Burst)   | Next         | X  | L  | H      | X  | X               | L  | L   | L-H | Data Out (Q) |
| NOP/Dummy Read (Begin Burst)  | External     | L  | L  | L      | H  | X               | H  | L   | L-H | Three-State  |
| Dummy Read (Continue Burst)   | Next         | X  | L  | H      | X  | X               | H  | L   | L-H | Three-State  |
| Write Cycle (Begin Burst)     | External     | L  | L  | L      | L  | L               | X  | L   | L-H | Data In (D)  |
| Write Cycle (Continue Burst)  | Next         | X  | L  | H      | X  | L               | X  | L   | L-H | Data In (D)  |
| NOP/WRITE ABORT (Begin Burst) | None         | L  | L  | L      | L  | H               | X  | L   | L-H | Three-State  |
| WRITE ABORT (Continue Burst)  | Next         | X  | L  | H      | X  | H               | X  | L   | L-H | Three-State  |
| IGNORE CLOCK EDGE (Stall)     | Current      | X  | L  | X      | X  | X               | X  | H   | L-H | -            |
| SLEEP MODE                    | None         | X  | H  | X      | X  | X               | X  | X   | X   | Three-State  |

#### Notes:

- X = “Don’t Care”, H = Logic HIGH, L = Logic LOW, CE stands for ALL Chip Enables active. BW<sub>x</sub> = L signifies at least one Byte Write Select is active, BW<sub>x</sub> = Valid signifies that the desired Byte Write Selects are asserted, see Write Cycle Description table for details.
- Write is defined by WE and BW<sub>x</sub>. See Write Cycle Description table for details.
- When a write cycle is detected, all I/Os are three-stated, even during Byte Writes.
- The DQ and DQP pins are controlled by the current cycle and the OE signal.
- CEN = H inserts wait states.
- Device will power-up deselected and the I/Os in a three-state condition, regardless of OE.
- OE is asynchronous and is not sampled with the clock rise. It is masked internally during write cycles. During a read cycle DQs and DQP<sub>x</sub> = Three-state when OE is inactive or when the device is deselected, and DQs = data when OE is active.

Accesses pending when entering the “sleep” mode are not considered valid nor is the completion of the operation guaranteed. The device must be deselected prior to entering the “sleep” mode. CE<sub>1</sub>, CE<sub>2</sub>, and CE<sub>3</sub> must remain inactive for the duration of t<sub>ZZREC</sub> after the ZZ input returns LOW.

### Interleaved Burst Address Table (MODE = Floating or V<sub>DD</sub>)

| First Address | Second Address | Third Address | Fourth Address |
|---------------|----------------|---------------|----------------|
| A1,A0         | A1,A0          | A1,A0         | A1,A0          |
| 00            | 01             | 10            | 11             |
| 01            | 00             | 11            | 10             |
| 10            | 11             | 00            | 01             |
| 11            | 10             | 01            | 00             |

### Linear Burst Address Table (MODE = GND)

| First Address | Second Address | Third Address | Fourth Address |
|---------------|----------------|---------------|----------------|
| A1,A0         | A1,A0          | A1,A0         | A1,A0          |
| 00            | 01             | 10            | 11             |
| 01            | 10             | 11            | 00             |
| 10            | 11             | 00            | 01             |
| 11            | 00             | 01            | 10             |



**Partial Write Cycle Description**<sup>[2, 3, 4, 9]</sup>

| Function (CY7C1354C)                                   | $\overline{WE}$ | $\overline{BW}_d$ | $\overline{BW}_c$ | $\overline{BW}_b$ | $\overline{BW}_a$ |
|--|-----------------|-------------------|-------------------|-------------------|-------------------|
| Read   | H               | X                 | X                 | X                 | X                 |
| Write –No bytes written                                | L               | H                 | H                 | H                 | H                 |
| Write Byte a – (DQ <sub>a</sub> and DQP <sub>a</sub> ) | L               | H                 | H                 | H                 | L                 |
| Write Byte b – (DQ <sub>b</sub> and DQP <sub>b</sub> ) | L               | H                 | H                 | L                 | H                 |
| Write Bytes b, a                                       | L               | H                 | H                 | L                 | L                 |
| Write Byte c – (DQ <sub>c</sub> and DQP <sub>c</sub> ) | L               | H                 | L                 | H                 | H                 |
| Write Bytes c, a                                       | L               | H                 | L                 | H                 | L                 |
| Write Bytes c, b                                       | L               | H                 | L                 | L                 | H                 |
| Write Bytes c, b, a                                    | L               | H                 | L                 | L                 | L                 |
| Write Byte d – (DQ <sub>d</sub> and DQP <sub>d</sub> ) | L               | L                 | H                 | H                 | H                 |
| Write Bytes d, a                                       | L               | L                 | H                 | H                 | L                 |
| Write Bytes d, b                                       | L               | L                 | H                 | L                 | H                 |
| Write Bytes d, b, a                                    | L               | L                 | H                 | L                 | L                 |
| Write Bytes d, c                                       | L               | L                 | L                 | H                 | H                 |
| Write Bytes d, c, a                                    | L               | L                 | L                 | H                 | L                 |
| Write Bytes d, c, b                                    | L               | L                 | L                 | L                 | H                 |
| Write All Bytes  | L               | L                 | L                 | L                 | L                 |

**Partial Write Cycle Description**<sup>[2, 3, 4, 9]</sup>

| Function (CY7C1356C)                                   | $\overline{WE}$ | $\overline{BW}_b$ | $\overline{BW}_a$ |
|--|-----------------|-------------------|-------------------|
| Read   | H               | x                 | x                 |
| Write – No Bytes Written                               | L               | H                 | H                 |
| Write Byte a – (DQ <sub>a</sub> and DQP <sub>a</sub> ) | L               | H                 | L                 |
| Write Byte b – (DQ <sub>b</sub> and DQP <sub>b</sub> ) | L               | L                 | H                 |
| Write Both Bytes                                       | L               | L                 | L                 |

**IEEE 1149.1 Serial Boundary Scan (JTAG)**

The CY7C1354C/CY7C1356C incorporates a serial boundary scan test access port (TAP) in the BGA package only. The TQFP package does not offer this functionality. This part operates in accordance with IEEE Standard 1149.1-1900, but doesn't have the set of functions required for full 1149.1 compliance. These functions from the IEEE specification are excluded because their inclusion places an added delay in the critical speed path of the SRAM. Note the TAP controller functions in a manner that does not conflict with the operation of other devices using 1149.1 fully compliant TAPs. The TAP operates using JEDEC-standard 3.3V or 2.5V I/O logic levels.

**Note:**

9. Table only lists a partial listing of the byte write combinations. Any combination of  $\overline{BW}_x$  is valid. Appropriate write will be done based on which byte write is active.

The CY7C1354C/CY7C1356C contains a TAP controller, instruction register, boundary scan register, bypass register, and ID register.

**Disabling the JTAG Feature**

It is possible to operate the SRAM without using the JTAG feature. To disable the TAP controller, TCK must be tied LOW ( $V_{SS}$ ) to prevent clocking of the device. TDI and TMS are internally pulled up and may be unconnected. They may alternately be connected to  $V_{DD}$  through a pull-up resistor. TDO should be left unconnected. Upon power-up, the device will come up in a reset state which will not interfere with the operation of the device.

### TAP Controller State Diagram

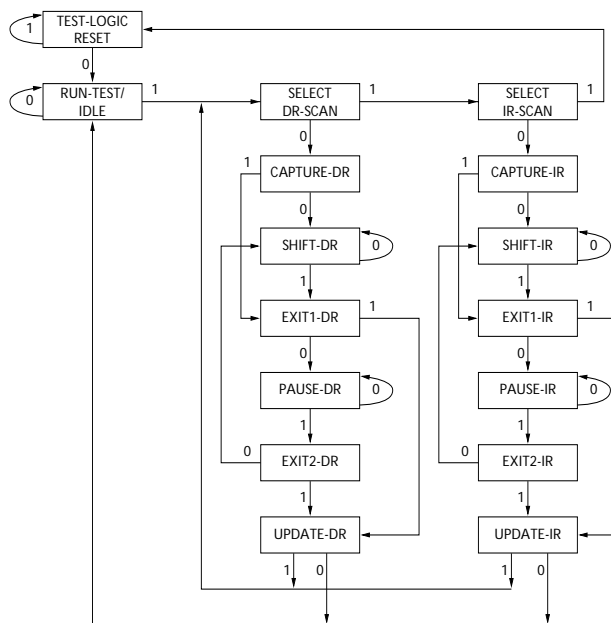

The 0/1 next to each state represents the value of TMS at the rising edge of TCK.

#### Test Access Port (TAP)

##### Test Clock (TCK)

The test clock is used only with the TAP controller. All inputs are captured on the rising edge of TCK. All outputs are driven from the falling edge of TCK.

##### Test MODE SELECT (TMS)

The TMS input is used to give commands to the TAP controller and is sampled on the rising edge of TCK. It is allowable to leave this ball unconnected if the TAP is not used. The ball is pulled up internally, resulting in a logic HIGH level.

##### Test Data-In (TDI)

The TDI ball is used to serially input information into the registers and can be connected to the input of any of the registers. The register between TDI and TDO is chosen by the instruction that is loaded into the TAP instruction register. TDI is internally pulled up and can be unconnected if the TAP is unused in an application. TDI is connected to the most significant bit (MSB) of any register. (See Tap Controller Block Diagram.)

##### Test Data-Out (TDO)

The TDO output ball is used to serially clock data-out from the registers. The output is active depending upon the current state of the TAP state machine. The output changes on the falling edge of TCK. TDO is connected to the least significant bit (LSB) of any register. (See Tap Controller State Diagram.)

### TAP Controller Block Diagram

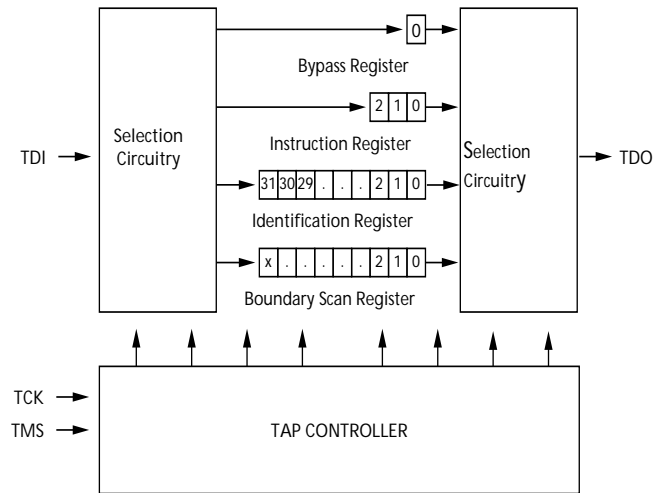

#### Performing a TAP Reset

A RESET is performed by forcing TMS HIGH ( $V_{DD}$ ) for five rising edges of TCK. This RESET does not affect the operation of the SRAM and may be performed while the SRAM is operating.

At power-up, the TAP is reset internally to ensure that TDO comes up in a High-Z state.

#### TAP Registers

Registers are connected between the TDI and TDO balls and allow data to be scanned into and out of the SRAM test circuitry. Only one register can be selected at a time through the instruction register. Data is serially loaded into the TDI ball on the rising edge of TCK. Data is output on the TDO ball on the falling edge of TCK.

##### Instruction Register

Three-bit instructions can be serially loaded into the instruction register. This register is loaded when it is placed between the TDI and TDO balls as shown in the Tap Controller Block Diagram. Upon power-up, the instruction register is loaded with the IDCODE instruction. It is also loaded with the IDCODE instruction if the controller is placed in a reset state as described in the previous section.

When the TAP controller is in the Capture-IR state, the two least significant bits are loaded with a binary "01" pattern to allow for fault isolation of the board-level serial test data path.

##### Bypass Register

To save time when serially shifting data through registers, it is sometimes advantageous to skip certain chips. The bypass register is a single-bit register that can be placed between the TDI and TDO balls. This allows data to be shifted through the SRAM with minimal delay. The bypass register is set LOW ( $V_{SS}$ ) when the BYPASS instruction is executed.

##### Boundary Scan Register

The boundary scan register is connected to all the input and bidirectional balls on the SRAM.

The boundary scan register is loaded with the contents of the RAM I/O ring when the TAP controller is in the Capture-DR

state and is then placed between the TDI and TDO balls when the controller is moved to the Shift-DR state. The EXTEST, SAMPLE/PRELOAD and SAMPLE Z instructions can be used to capture the contents of the I/O ring.

The Boundary Scan Order tables show the order in which the bits are connected. Each bit corresponds to one of the bumps on the SRAM package. The MSB of the register is connected to TDI and the LSB is connected to TDO.

#### Identification (ID) Register

The ID register is loaded with a vendor-specific, 32-bit code during the Capture-DR state when the IDCODE command is loaded in the instruction register. The IDCODE is hardwired into the SRAM and can be shifted out when the TAP controller is in the Shift-DR state. The ID register has a vendor code and other information described in the Identification Register Definitions table.

### TAP Instruction Set

#### Overview

Eight different instructions are possible with the three-bit instruction register. All combinations are listed in the Instruction Codes table. Three of these instructions are listed as RESERVED and should not be used. The other five instructions are described in detail below.

The TAP controller used in this SRAM is not fully compliant to the 1149.1 convention because some of the mandatory 1149.1 instructions are not fully implemented.

The TAP controller cannot be used to load address data or control signals into the SRAM and cannot preload the I/O buffers. The SRAM does not implement the 1149.1 commands EXTEST or INTEST or the PRELOAD portion of SAMPLE/PRELOAD; rather, it performs a capture of the I/O ring when these instructions are executed.

Instructions are loaded into the TAP controller during the Shift-IR state when the instruction register is placed between TDI and TDO. During this state, instructions are shifted through the instruction register through the TDI and TDO balls. To execute the instruction once it is shifted in, the TAP controller needs to be moved into the Update-IR state.

#### EXTEST

EXTEST is a mandatory 1149.1 instruction which is to be executed whenever the instruction register is loaded with all 0s. EXTEST is not implemented in this SRAM TAP controller, and therefore this device is not compliant to 1149.1. The TAP controller does not recognize an all-0 instruction.

When an EXTEST instruction is loaded into the instruction register, the SRAM responds as if a SAMPLE/PRELOAD instruction has been loaded. There is one difference between the two instructions. Unlike the SAMPLE/PRELOAD instruction, EXTEST places the SRAM outputs in a High-Z state.

#### IDCODE

The IDCODE instruction causes a vendor-specific, 32-bit code to be loaded into the instruction register. It also places the instruction register between the TDI and TDO balls and allows

the IDCODE to be shifted out of the device when the TAP controller enters the Shift-DR state.

The IDCODE instruction is loaded into the instruction register upon power-up or whenever the TAP controller is given a test logic reset state.

#### SAMPLE Z

The SAMPLE Z instruction causes the boundary scan register to be connected between the TDI and TDO balls when the TAP controller is in a Shift-DR state. It also places all SRAM outputs into a High-Z state.

#### SAMPLE/PRELOAD

SAMPLE / PRELOAD is a 1149.1 mandatory instruction. When the SAMPLE / PRELOAD instructions are loaded into the instruction register and the TAP controller is in the Capture-DR state, a snapshot of data on the inputs and output pins is captured in the boundary scan register.

The user must be aware that the TAP controller clock can only operate at a frequency up to 20 MHz, while the SRAM clock operates more than an order of magnitude faster. Because there is a large difference in the clock frequencies, it is possible that during the Capture-DR state, an input or output will undergo a transition. The TAP may then try to capture a signal while in transition (metastable state). This will not harm the device, but there is no guarantee as to the value that will be captured. Repeatable results may not be possible.

To guarantee that the boundary scan register will capture the correct value of a signal, the SRAM signal must be stabilized long enough to meet the TAP controller's capture set-up plus hold times ( $t_{CS}$  and  $t_{CH}$ ). The SRAM clock input might not be captured correctly if there is no way in a design to stop (or slow) the clock during a SAMPLE / PRELOAD instruction. If this is an issue, it is still possible to capture all other signals and simply ignore the value of the CK and CK# captured in the boundary scan register.

Once the data is captured, it is possible to shift out the data by putting the TAP into the Shift-DR state. This places the boundary scan register between the TDI and TDO pins.

PRELOAD allows an initial data pattern to be placed at the latched parallel outputs of the boundary scan register cells prior to the selection of another boundary scan test operation.

The shifting of data for the SAMPLE and PRELOAD phases can occur concurrently when required—that is, while data captured is shifted out, the preloaded data can be shifted in.

#### BYPASS

When the BYPASS instruction is loaded in the instruction register and the TAP is placed in a Shift-DR state, the bypass register is placed between the TDI and TDO balls. The advantage of the BYPASS instruction is that it shortens the boundary scan path when multiple devices are connected together on a board.

#### Reserved

These instructions are not implemented but are reserved for future use. Do not use these instructions.

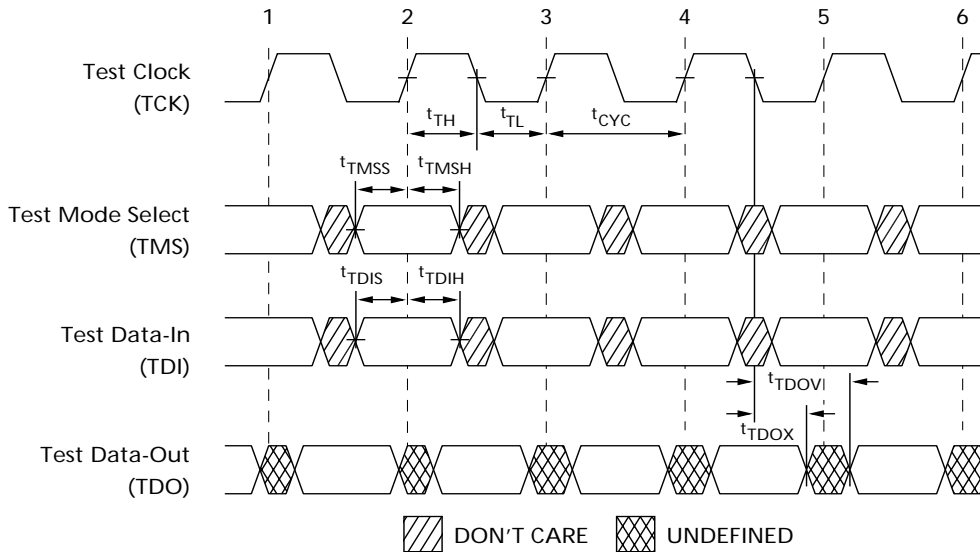
**TAP Timing**

**TAP AC Switching Characteristics** Over the Operating Range<sup>[10, 11]</sup>

| Parameter           | Description                   | Min. | Max. | Unit |
|---------------------|-------------------------------|------|------|------|
| <b>Clock</b>        |                               |      |      |      |
| $t_{TCYC}$          | TCK Clock Cycle Time          | 50   |      | ns   |
| $t_{TF}$            | TCK Clock Frequency           |      | 20   | MHz  |
| $t_{TH}$            | TCK Clock HIGH time           | 25   |      | ns   |
| $t_{TL}$            | TCK Clock LOW time            | 25   |      | ns   |
| <b>Output Times</b> |                               |      |      |      |
| $t_{TDOV}$          | TCK Clock LOW to TDO Valid    |      | 5    | ns   |
| $t_{TDOX}$          | TCK Clock LOW to TDO Invalid  | 0    |      | ns   |
| <b>Set-up Times</b> |                               |      |      |      |
| $t_{TMSS}$          | TMS Set-up to TCK Clock Rise  | 5    |      | ns   |
| $t_{TDIS}$          | TDI Set-up to TCK Clock Rise  | 5    |      | ns   |
| $t_{CS}$            | Capture Set-up to TCK Rise    | 5    |      |      |
| <b>Hold Times</b>   |                               |      |      |      |
| $t_{TMSH}$          | TMS hold after TCK Clock Rise | 5    |      | ns   |
| $t_{TDIH}$          | TDI Hold after Clock Rise     | 5    |      | ns   |
| $t_{CH}$            | Capture Hold after Clock Rise | 5    |      | ns   |

**Notes:**

10.  $t_{CS}$  and  $t_{CH}$  refer to the set-up and hold time requirements of latching data from the boundary scan register.

11. Test conditions are specified using the load in TAP AC test Conditions.  $t_R/t_F = 1\text{ns}$ .

**3.3V TAP AC Test Conditions**

Input pulse levels ..... V<sub>SS</sub> to 3.3V  
 Input rise and fall times ..... 1 ns  
 Input timing reference levels ..... 1.5V  
 Output reference levels ..... 1.5V  
 Test load termination supply voltage ..... 1.5V

**2.5V TAP AC Test Conditions**

Input pulse levels ..... V<sub>SS</sub> to 2.5V  
 Input rise and fall time ..... 1 ns  
 Input timing reference levels ..... 1.25V  
 Output reference levels ..... 1.25V  
 Test load termination supply voltage ..... 1.25V

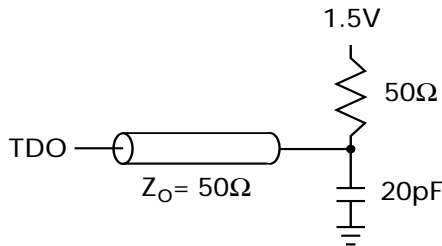
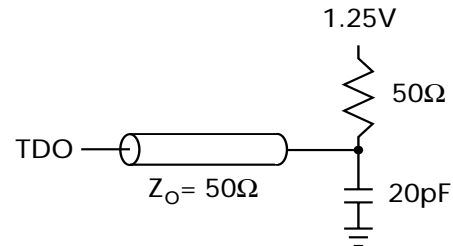
**3.3V TAP AC Output Load Equivalent**

**2.5V TAP AC Output Load Equivalent**

**TAP DC Electrical Characteristics And Operating Conditions**

(0°C < T<sub>A</sub> < +70°C; V<sub>DD</sub> = 3.3V ±0.165V unless otherwise noted)<sup>[12]</sup>

| PARAMETER        | DESCRIPTION         | TEST CONDITIONS                                    | MIN.                    | MAX. | UNIT                  |
|------------------|---------------------|--|-------------------------|------|-----------------------|
| V <sub>OH1</sub> | Output HIGH Voltage | I <sub>OH</sub> = -4.0 mA, V <sub>DDQ</sub> = 3.3V | 2.4                     |      | V                     |
|                  |                     | I <sub>OH</sub> = -1.0 mA, V <sub>DDQ</sub> = 2.5V | 2.0                     |      | V                     |
| V <sub>OH2</sub> | Output HIGH Voltage | I <sub>OH</sub> = -100 μA                          | V <sub>DDQ</sub> = 3.3V | 2.9  | V                     |
|                  |                     |  | V <sub>DDQ</sub> = 2.5V | 2.1  | V                     |
| V <sub>OL1</sub> | Output LOW Voltage  | I <sub>OL</sub> = 8.0 mA                           | V <sub>DDQ</sub> = 3.3V | 0.4  | V                     |
|                  |                     |  | V <sub>DDQ</sub> = 2.5V | 0.4  | V                     |
| V <sub>OL2</sub> | Output LOW Voltage  | I <sub>OL</sub> = 100 μA                           | V <sub>DDQ</sub> = 3.3V | 0.2  | V                     |
|                  |                     |  | V <sub>DDQ</sub> = 2.5V | 0.2  | V                     |
| V <sub>IH</sub>  | Input HIGH Voltage  |  | V <sub>DDQ</sub> = 3.3V | 2.0  | V <sub>DD</sub> + 0.3 |
|                  |                     |  | V <sub>DDQ</sub> = 2.5V | 1.7  | V <sub>DD</sub> + 0.3 |
| V <sub>IL</sub>  | Input LOW Voltage   |  | V <sub>DDQ</sub> = 3.3V | -0.3 | 0.8                   |
|                  |                     |  | V <sub>DDQ</sub> = 2.5V | -0.3 | 0.7                   |
| I <sub>X</sub>   | Input Load Current  | GND ≤ V <sub>IN</sub> ≤ V <sub>DDQ</sub>           | -5                      | 5    | μA                    |

**Identification Register Definitions**

| Instruction Field                         | CY7C1354C         | CY7C1356C         | Description                                  |
|---|-------------------|-------------------|--|
| Revision Number (31:29)                   | 000               | 000               | Reserved for version number.                 |
| Cypress Device ID (28:12) <sup>[13]</sup> | 01011001000100110 | 01011001000010110 | Reserved for future use.                     |
| Cypress JEDEC ID (11:1)                   | 00000110100       | 00000110100       | Allows unique identification of SRAM vendor. |
| ID Register Presence (0)                  | 1                 | 1                 | Indicate the presence of an ID register.     |

**Notes:**

12. All voltages referenced to V<sub>SS</sub> (GND).  
 13. Bit #24 is "1" in the Register Definitions for both 2.5V and 3.3V versions of this device.

**Scan Register Sizes**

| Register Name                               | Bit Size |
|---|----------|
| Instruction                                 | 3        |
| Bypass                                      | 1        |
| ID  | 32       |
| Boundary Scan Order (119-ball BGA package)  | 69       |
| Boundary Scan Order (165-ball fBGA package) | 69       |

**Identification Codes**

| Instruction    | Code | Description  |
|----------------|------|--|
| EXTEST         | 000  | Captures the Input/Output ring contents. Places the boundary scan register between the TDI and TDO. Forces all SRAM outputs to High-Z state. |
| IDCODE         | 001  | Loads the ID register with the vendor ID code and places the register between TDI and TDO. This operation does not affect SRAM operation.    |
| SAMPLE Z       | 010  | Captures the Input/Output contents. Places the boundary scan register between TDI and TDO. Forces all SRAM output drivers to a High-Z state. |
| RESERVED       | 011  | Do Not Use: This instruction is reserved for future use.   |
| SAMPLE/PRELOAD | 100  | Captures the Input/Output ring contents. Places the boundary scan register between TDI and TDO. Does not affect the SRAM operation.          |
| RESERVED       | 101  | Do Not Use: This instruction is reserved for future use.   |
| RESERVED       | 110  | Do Not Use: This instruction is reserved for future use.   |
| BYPASS         | 111  | Places the bypass register between TDI and TDO. This operation does not affect SRAM operation.   |

**Boundary Scan Exit Order (x36)**

| Bit # | 119-Ball ID | 165-Ball ID |
|-------|-------------|-------------|
| 1     | K4          | B6          |
| 2     | H4          | B7          |
| 3     | M4          | A7          |
| 4     | F4          | B8          |
| 5     | B4          | A8          |
| 6     | G4          | A9          |
| 7     | C3          | B10         |
| 8     | B3          | A10         |
| 9     | D6          | C11         |
| 10    | H7          | E10         |
| 11    | G6          | F10         |
| 12    | E6          | G10         |
| 13    | D7          | D10         |
| 14    | E7          | D11         |
| 15    | F6          | E11         |
| 16    | G7          | F11         |
| 17    | H6          | G11         |
| 18    | T7          | H11         |
| 19    | K7          | J10         |
| 20    | L6          | K10         |
| 21    | N6          | L10         |
| 22    | P7          | M10         |

**Boundary Scan Exit Order (x36) (continued)**

| Bit # | 119-Ball ID | 165-Ball ID |
|-------|-------------|-------------|
| 23    | N7          | J11         |
| 24    | M6          | K11         |
| 25    | L7          | L11         |
| 26    | K6          | M11         |
| 27    | P6          | N11         |
| 28    | T4          | R11         |
| 29    | A3          | R10         |
| 30    | C5          | P10         |
| 31    | B5          | R9          |
| 32    | A5          | P9          |
| 33    | C6          | R8          |
| 34    | A6          | P8          |
| 35    | P4          | R6          |
| 36    | N4          | P6          |
| 37    | R6          | R4          |
| 38    | T5          | P4          |
| 39    | T3          | R3          |
| 40    | R2          | P3          |
| 41    | R3          | R1          |
| 42    | P2          | N1          |
| 43    | P1          | L2          |
| 44    | L2          | K2          |
| 45    | K1          | J2          |



**Boundary Scan Exit Order (x36)** (continued)

| Bit # | 119-Ball ID                 | 165-Ball ID                 |
|-------|-----------------------------|-----------------------------|
| 46    | N2                          | M2                          |
| 47    | N1                          | M1                          |
| 48    | M2                          | L1                          |
| 49    | L1                          | K1                          |
| 50    | K2                          | J1                          |
| 51    | Not Bonded<br>(Preset to 1) | Not Bonded<br>(Preset to 1) |
| 52    | H1                          | G2                          |
| 53    | G2                          | F2                          |
| 54    | E2                          | E2                          |
| 55    | D1                          | D2                          |
| 56    | H2                          | G1                          |
| 57    | G1                          | F1                          |
| 58    | F2                          | E1                          |
| 59    | E1                          | D1                          |
| 60    | D2                          | C1                          |
| 61    | C2                          | B2                          |
| 62    | A2                          | A2                          |
| 63    | E4                          | A3                          |
| 64    | B2                          | B3                          |
| 65    | L3                          | B4                          |
| 66    | G3                          | A4                          |
| 67    | G5                          | A5                          |
| 68    | L5                          | B5                          |
| 69    | B6                          | A6                          |

**Boundary Scan Exit Order (x18)** (continued)

| Bit # | 119-Ball ID                 | 165-Ball ID                 |
|-------|-----------------------------|-----------------------------|
| 15    | F6                          | E11                         |
| 16    | G7                          | F11                         |
| 17    | H6                          | G11                         |
| 18    | T7                          | H11                         |
| 19    | K7                          | J10                         |
| 20    | L6                          | K10                         |
| 21    | N6                          | L10                         |
| 22    | P7                          | M10                         |
| 23    | Not Bonded<br>(Preset to 0) | Not Bonded<br>(Preset to 0) |
| 24    | Not Bonded<br>(Preset to 0) | Not Bonded<br>(Preset to 0) |
| 25    | Not Bonded<br>(Preset to 0) | Not Bonded<br>(Preset to 0) |
| 26    | Not Bonded<br>(Preset to 0) | Not Bonded<br>(Preset to 0) |
| 27    | Not Bonded<br>(Preset to 0) | Not Bonded<br>(Preset to 0) |
| 28    | T6                          | R11                         |
| 29    | A3                          | R10                         |
| 30    | C5                          | P10                         |
| 31    | B5                          | R9                          |
| 32    | A5                          | P9                          |
| 33    | C6                          | R8                          |
| 34    | A6                          | P8                          |
| 35    | P4                          | R6                          |
| 36    | N4                          | P6                          |
| 37    | R6                          | R4                          |
| 38    | T5                          | P4                          |
| 39    | T3                          | R3                          |
| 40    | R2                          | P3                          |
| 41    | R3                          | R1                          |
| 42    | Not Bonded<br>(Preset to 0) | Not Bonded<br>(Preset to 0) |
| 43    | Not Bonded<br>(Preset to 0) | Not Bonded<br>(Preset to 0) |
| 44    | Not Bonded<br>(Preset to 0) | Not Bonded<br>(Preset to 0) |
| 45    | Not Bonded<br>(Preset to 0) | Not Bonded<br>(Preset to 0) |
| 46    | P2                          | N1                          |
| 47    | N1                          | M1                          |
| 48    | M2                          | L1                          |
| 49    | L1                          | K1                          |
| 50    | K2                          | J1                          |
| 51    | Not Bonded<br>(Preset to 1) | Not Bonded<br>(Preset to 1) |

**Boundary Scan Exit Order (x18)**

| Bit # | 119-Ball ID                 | 165-Ball ID                 |
|-------|-----------------------------|-----------------------------|
| 1     | K4                          | B6                          |
| 2     | H4                          | B7                          |
| 3     | M4                          | A7                          |
| 4     | F4                          | B8                          |
| 5     | B4                          | A8                          |
| 6     | G4                          | A9                          |
| 7     | C3                          | B10                         |
| 8     | B3                          | A10                         |
| 9     | T2                          | A11                         |
| 10    | Not Bonded<br>(Preset to 0) | Not Bonded<br>(Preset to 0) |
| 11    | Not Bonded<br>(Preset to 0) | Not Bonded<br>(Preset to 0) |
| 12    | Not Bonded<br>(Preset to 0) | Not Bonded<br>(Preset to 0) |
| 13    | D6                          | C11                         |
| 14    | E7                          | D11                         |

**Boundary Scan Exit Order (x18)** (continued)

| Bit # | 119-Ball ID                 | 165-Ball ID                 |
|-------|-----------------------------|-----------------------------|
| 52    | H1                          | G2                          |
| 53    | G2                          | F2                          |
| 54    | E2                          | E2                          |
| 55    | D1                          | D2                          |
| 56    | Not Bonded<br>(Preset to 0) | Not Bonded<br>(Preset to 0) |
| 57    | Not Bonded<br>(Preset to 0) | Not Bonded<br>(Preset to 0) |
| 58    | Not Bonded<br>(Preset to 0) | Not Bonded<br>(Preset to 0) |
| 59    | Not Bonded<br>(Preset to 0) | Not Bonded<br>(Preset to 0) |
| 60    | Not Bonded<br>(Preset to 0) | Not Bonded<br>(Preset to 0) |
| 61    | C2                          | B2                          |
| 62    | A2                          | A2                          |
| 63    | E4                          | A3                          |
| 64    | B2                          | B3                          |
| 65    | Not Bonded<br>(Preset to 0) | Not Bonded<br>(Preset to 0) |
| 66    | G3                          | Not Bonded<br>(Preset to 0) |
| 67    | Not Bonded<br>(Preset to 0) | A4                          |
| 68    | L5                          | B5                          |
| 69    | B6                          | A6                          |





**Maximum Ratings**

(Above which the useful life may be impaired. For user guidelines, not tested.)

- Storage Temperature ..... -65°C to +150°C
- Ambient Temperature with Power Applied..... -55°C to +125°C
- Supply Voltage on V<sub>DD</sub> Relative to GND..... -0.5V to +4.6V
- DC to Outputs in Three-State..... -0.5V to V<sub>DDQ</sub> + 0.5V
- DC Input Voltage..... -0.5V to V<sub>DD</sub> + 0.5V

- Current into Outputs (LOW)..... 20 mA
- Static Discharge Voltage..... > 2001V (per MIL-STD-883, Method 3015)
- Latch-up Current..... > 200 mA

**Operating Range**

| Range      | Ambient Temperature | V <sub>DD</sub> | V <sub>DDQ</sub>             |
|------------|---------------------|-----------------|------------------------------|
| Commercial | 0°C to +70°C        | 3.3V - 5%/+10%  | 2.5V - 5% to V <sub>DD</sub> |
| Industrial | -40°C to +85°C      |                 |                              |

**Electrical Characteristics** Over the Operating Range<sup>[14, 15]</sup>

| Parameter               | Description                                 | Test Conditions  | Min.                    | Max.                   | Unit |    |
|-------------------------|---|--|-------------------------|------------------------|------|----|
| V <sub>DD</sub>         | Power Supply Voltage                        |  | 3.135                   | 3.6                    | V    |    |
| V <sub>DDQ</sub>        | I/O Supply Voltage                          | V <sub>DDQ</sub> = 3.3V  | 3.135                   | V <sub>DD</sub>        | V    |    |
|                         |   | V <sub>DDQ</sub> = 2.5V  | 2.375                   | 2.625                  | V    |    |
| V <sub>OH</sub>         | Output HIGH Voltage                         | V <sub>DD</sub> = Min., I <sub>OH</sub> = -4.0 mA, V <sub>DDQ</sub> = 3.3V   | 2.4                     |                        | V    |    |
|                         |   | V <sub>DD</sub> = Min., I <sub>OH</sub> = -1.0 mA, V <sub>DDQ</sub> = 2.5V   | 2.0                     |                        | V    |    |
| V <sub>OL</sub>         | Output LOW Voltage                          | V <sub>DD</sub> = Min., I <sub>OL</sub> = 8.0 mA, V <sub>DDQ</sub> = 3.3V  |                         | 0.4                    | V    |    |
|                         |   | V <sub>DD</sub> = Min., I <sub>OL</sub> = 1.0 mA, V <sub>DDQ</sub> = 2.5V  |                         | 0.4                    | V    |    |
| V <sub>IH</sub>         | Input HIGH Voltage                          | V <sub>DDQ</sub> = 3.3V  | 2.0                     | V <sub>DD</sub> + 0.3V | V    |    |
|                         |   | V <sub>DDQ</sub> = 2.5V  | 1.7                     | V <sub>DD</sub> + 0.3V | V    |    |
| V <sub>IL</sub>         | Input LOW Voltage <sup>[16]</sup>           | V <sub>DDQ</sub> = 3.3V  | -0.3                    | 0.8                    | V    |    |
|                         |   | V <sub>DDQ</sub> = 2.5V  | -0.3                    | 0.7                    | V    |    |
| I <sub>X</sub>          | Input Load Current except ZZ and MODE       | GND ≤ V <sub>I</sub> ≤ V <sub>DDQ</sub>  | -5                      | 5                      | μA   |    |
|                         |   | Input Current of MODE  | Input = V <sub>SS</sub> | -30                    |      | μA |
|                         |   |  | Input = V <sub>DD</sub> |                        | 5    | μA |
|                         |   | Input Current of ZZ  | Input = V <sub>SS</sub> | -5                     |      | μA |
| Input = V <sub>DD</sub> |   |  | 30                      | μA                     |      |    |
| I <sub>OZ</sub>         | Output Leakage Current                      | GND ≤ V <sub>I</sub> ≤ V <sub>DDQ</sub> , Output Disabled  | -5                      | 5                      | μA   |    |
| I <sub>DD</sub>         | V <sub>DD</sub> Operating Supply            | V <sub>DD</sub> = Max., I <sub>OUT</sub> = 0 mA, f = f <sub>MAX</sub> = 1/t <sub>CYC</sub>   | 4.4-ns cycle, 225 MHz   | 250                    | mA   |    |
|                         |   |  | 5-ns cycle, 200 MHz     | 220                    | mA   |    |
|                         |   |  | 6-ns cycle, 166 MHz     | 180                    | mA   |    |
| I <sub>SB1</sub>        | Automatic CE Power-down Current—TTL Inputs  | Max. V <sub>DD</sub> , Device Deselected, V <sub>IN</sub> ≥ V <sub>IH</sub> or V <sub>IN</sub> ≤ V <sub>IL</sub> , f = f <sub>MAX</sub> = 1/t <sub>CYC</sub> | 4.4-ns cycle, 225 MHz   | 130                    | mA   |    |
|                         |   |  | 5-ns cycle, 200 MHz     | 120                    | mA   |    |
|                         |   |  | 6-ns cycle, 166 MHz     | 110                    | mA   |    |
| I <sub>SB2</sub>        | Automatic CE Power-down Current—CMOS Inputs | Max. V <sub>DD</sub> , Device Deselected, V <sub>IN</sub> ≤ 0.3V or V <sub>IN</sub> ≥ V <sub>DDQ</sub> - 0.3V, f = 0   | All speed grades        |                        | 35   | mA |
| I <sub>SB3</sub>        | Automatic CE Power-down Current—CMOS Inputs | Max. V <sub>DD</sub> , Device Deselected, V <sub>IN</sub> ≤ 0.3V or V <sub>IN</sub> ≥ V <sub>DDQ</sub> - 0.3V, f = f <sub>MAX</sub> = 1/t <sub>CYC</sub>     | 4.4-ns cycle, 225 MHz   | 120                    | mA   |    |
|                         |   |  | 5-ns cycle, 200 MHz     | 110                    | mA   |    |
|                         |   |  | 6-ns cycle, 166 MHz     | 100                    | mA   |    |
| I <sub>SB4</sub>        | Automatic CE Power-down Current—TTL Inputs  | Max. V <sub>DD</sub> , Device Deselected, V <sub>IN</sub> ≥ V <sub>IH</sub> or V <sub>IN</sub> ≤ V <sub>IL</sub> , f = 0                                     | All speed grades        |                        | 40   | mA |

Shaded areas contain advance information.

**Notes:**

- 14. Overshoot: V<sub>IH</sub>(AC) < V<sub>DD</sub> + 1.5V (Pulse width less than t<sub>CYC</sub>/2), undershoot: V<sub>IL</sub>(AC) > -2V (Pulse width less than t<sub>CYC</sub>/2).
- 15. T<sub>Power-up</sub>: Assumes a linear ramp from 0V to V<sub>DD</sub> (min.) within 200 ms. During this time V<sub>IH</sub> < V<sub>DD</sub> and V<sub>DDQ</sub> < V<sub>DD</sub>.

**Capacitance<sup>[16]</sup>**

| Parameter | Description              | Test Conditions   | BGA Max. | fBGA Max. | TQFP Max. | Unit |
|-----------|--------------------------|---|----------|-----------|-----------|------|
| $C_{IN}$  | Input Capacitance        | $T_A = 25^\circ\text{C}$ , $f = 1\text{ MHz}$ ,<br>$V_{DD} = 3.3\text{V}$ $V_{DDQ} = 2.5\text{V}$ | 5        | 5         | 5         | pF   |
| $C_{CLK}$ | Clock Input Capacitance  |   | 5        | 5         | 5         | pF   |
| $C_{I/O}$ | Input/Output Capacitance |   | 7        | 7         | 5         | pF   |

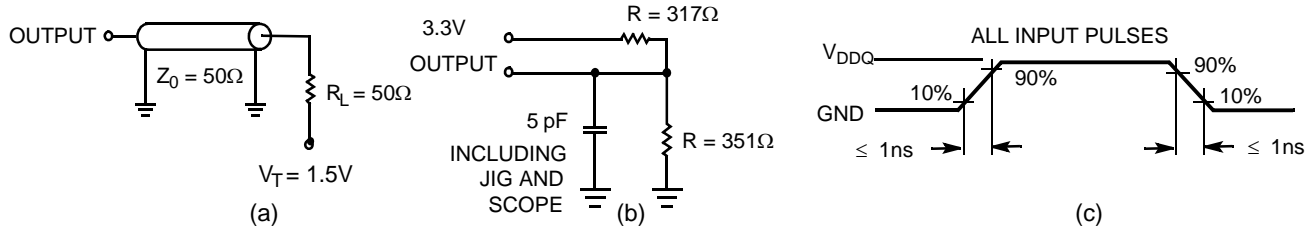
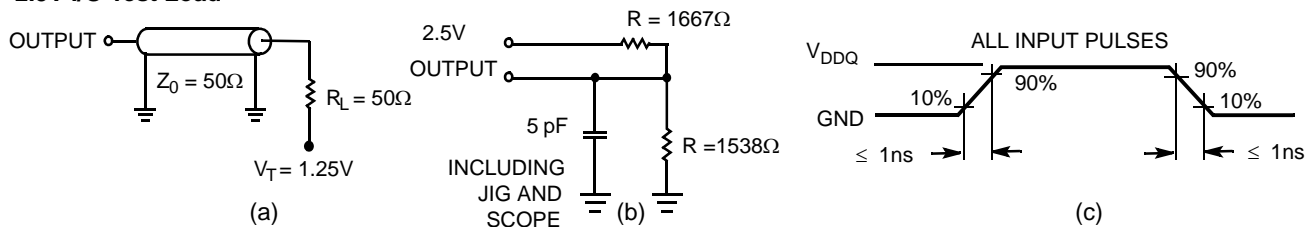
**AC Test Loads and Waveforms**
**3.3V I/O Test Load**

**2.5V I/O Test Load**

**Thermal Resistance<sup>[16]</sup>**

| Parameters    | Description                              | Test Conditions  | BGA Typ. | fBGA Typ. | TQFP Typ. | Unit               |
|---------------|--|--|----------|-----------|-----------|--------------------|
| $\Theta_{JA}$ | Thermal Resistance (Junction to Ambient) | Test conditions follow standard test methods and procedures for measuring thermal impedance, per EIA/JESD51. | 25       | 27        | 25        | $^\circ\text{C/W}$ |
| $\Theta_{JC}$ | Thermal Resistance (Junction to Case)    |  | 6        | 6         | 9         | $^\circ\text{C/W}$ |

**Switching Characteristics Over the Operating Range<sup>[19, 20]</sup>**

| Parameter           | Description  | -225 |      | -200 |      | -166 |      | Unit |
|---------------------|--|------|------|------|------|------|------|------|
|                     |  | Min. | Max. | Min. | Max. | Min. | Max. |      |
| $t_{Power}^{[17]}$  | $V_{CC}$ (typical) to the First Access Read or Write | 1    |      | 1    |      | 1    |      | ms   |
| <b>Clock</b>        |  |      |      |      |      |      |      |      |
| $t_{CYC}$           | Clock Cycle Time                                     | 4.4  |      | 5    |      | 6    |      | ns   |
| $F_{MAX}$           | Maximum Operating Frequency                          |      | 225  |      | 200  |      | 166  | MHz  |
| $t_{CH}$            | Clock HIGH   | 1.8  |      | 2.0  |      | 2.4  |      | ns   |
| $t_{CL}$            | Clock LOW  | 1.8  |      | 2.0  |      | 2.4  |      | ns   |
| <b>Output Times</b> |  |      |      |      |      |      |      |      |
| $t_{CO}$            | Data Output Valid after CLK Rise                     |      | 2.8  |      | 3.2  |      | 3.5  | ns   |
| $t_{EOV}$           | OE LOW to Output Valid                               |      | 2.8  |      | 3.2  |      | 3.5  | ns   |
| $t_{DOH}$           | Data Output Hold after CLK Rise                      | 1.25 |      | 1.5  |      | 1.5  |      | ns   |

Shaded areas contain advance information.

**Notes:**

16. Tested initially and after any design or process changes that may affect these parameters.

17. This part has a voltage regulator internally;  $t_{power}$  is the time power needs to be supplied above  $V_{DD}$  minimum initially, before a Read or Write operation can be initiated.

18.  $t_{CHZ}$ ,  $t_{CLZ}$ ,  $t_{EOLZ}$ , and  $t_{EOHZ}$  are specified with AC test conditions shown in (b) of AC Test Loads. Transition is measured  $\pm 200\text{ mV}$  from steady-state voltage.

19. Timing reference level is 1.5V when  $V_{DDQ} = 3.3\text{V}$  and is 1.25V when  $V_{DDQ} = 2.5\text{V}$ .

20. Test conditions shown in (a) of AC Test Loads unless otherwise noted.

**Switching Characteristics** Over the Operating Range (continued)<sup>[19, 20]</sup>

| Parameter           | Description   | -225 |      | -200 |      | -166 |      | Unit |
|---------------------|---|------|------|------|------|------|------|------|
|                     |   | Min. | Max. | Min. | Max. | Min. | Max. |      |
| t <sub>CHZ</sub>    | Clock to High-Z <sup>[18, 21, 22]</sup>                       | 1.25 | 2.8  | 1.5  | 3.2  | 1.5  | 3.5  | ns   |
| t <sub>CLZ</sub>    | Clock to Low-Z <sup>[18, 21, 22]</sup>                        | 1.25 |      | 1.5  |      | 1.5  |      | ns   |
| t <sub>EOHZ</sub>   | $\overline{OE}$ HIGH to Output High-Z <sup>[18, 21, 22]</sup> |      | 2.8  |      | 3.2  |      | 3.5  | ns   |
| t <sub>EOLZ</sub>   | $\overline{OE}$ LOW to Output Low-Z <sup>[18, 21, 22]</sup>   | 0    |      | 0    |      | 0    |      | ns   |
| <b>Set-up Times</b> |   |      |      |      |      |      |      |      |
| t <sub>AS</sub>     | Address Set-up before CLK Rise                                | 1.4  |      | 1.5  |      | 1.5  |      | ns   |
| t <sub>DS</sub>     | Data Input Set-up before CLK Rise                             | 1.4  |      | 1.5  |      | 1.5  |      | ns   |
| t <sub>CENS</sub>   | $\overline{CEN}$ Set-up before CLK Rise                       | 1.4  |      | 1.5  |      | 1.5  |      | ns   |
| t <sub>WES</sub>    | $\overline{WE}$ , $\overline{BW}_x$ Set-up before CLK Rise    | 1.4  |      | 1.5  |      | 1.5  |      | ns   |
| t <sub>ALS</sub>    | ADV/LD Set-up before CLK Rise                                 | 1.4  |      | 1.5  |      | 1.5  |      | ns   |
| t <sub>CES</sub>    | Chip Select Set-up  | 1.4  |      | 1.5  |      | 1.5  |      | ns   |
| <b>Hold Times</b>   |   |      |      |      |      |      |      |      |
| t <sub>AH</sub>     | Address Hold after CLK Rise                                   | 0.4  |      | 0.5  |      | 0.5  |      | ns   |
| t <sub>DH</sub>     | Data Input Hold after CLK Rise                                | 0.4  |      | 0.5  |      | 0.5  |      | ns   |
| t <sub>CENH</sub>   | $\overline{CEN}$ Hold after CLK Rise                          | 0.4  |      | 0.5  |      | 0.5  |      | ns   |
| t <sub>WEH</sub>    | $\overline{WE}$ , $\overline{BW}_x$ Hold after CLK Rise       | 0.4  |      | 0.5  |      | 0.5  |      | ns   |
| t <sub>ALH</sub>    | ADV/LD Hold after CLK Rise                                    | 0.4  |      | 0.5  |      | 0.5  |      | ns   |
| t <sub>CEH</sub>    | Chip Select Hold after CLK Rise                               | 0.4  |      | 0.5  |      | 0.5  |      | ns   |

**Notes:**

21. At any given voltage and temperature, t<sub>EOHZ</sub> is less than t<sub>EOLZ</sub> and t<sub>CHZ</sub> is less than t<sub>CLZ</sub> to eliminate bus contention between SRAMs when sharing the same data bus. These specifications do not imply a bus contention condition, but reflect parameters guaranteed over worst case user conditions. Device is designed to achieve High-Z prior to Low-Z under the same system conditions.

22. This parameter is sampled and not 100% tested.

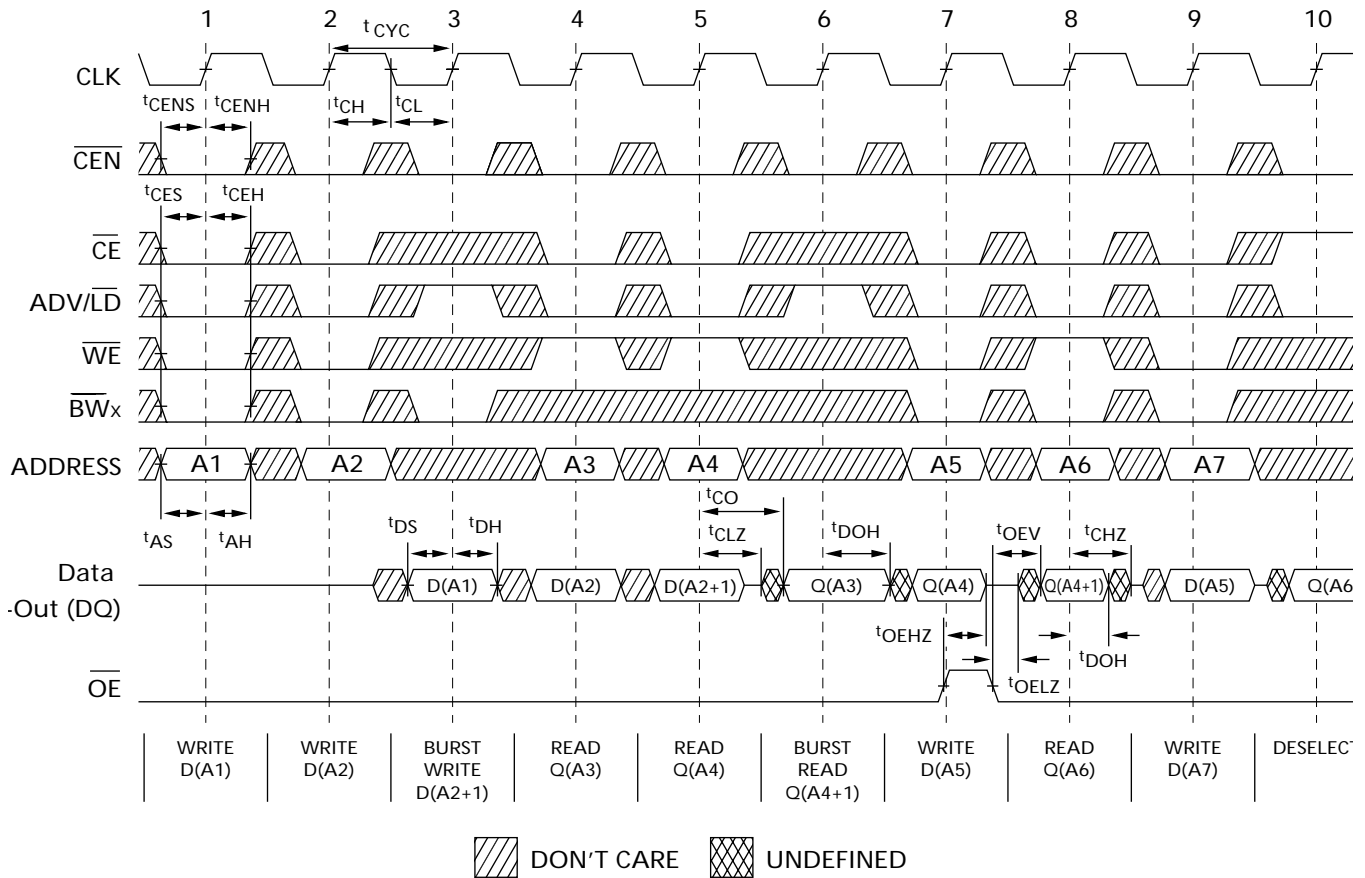
**Switching Waveforms**
**Read/Write Timing<sup>[23,24,25]</sup>**

**Notes:**

23. For this waveform  $\overline{ZZ}$  is tied low.

24. When  $\overline{CE}$  is LOW,  $\overline{CE}_1$  is LOW,  $\overline{CE}_2$  is HIGH and  $\overline{CE}_3$  is LOW. When  $\overline{CE}$  is HIGH,  $\overline{CE}_1$  is HIGH or  $\overline{CE}_2$  is LOW or  $\overline{CE}_3$  is HIGH.

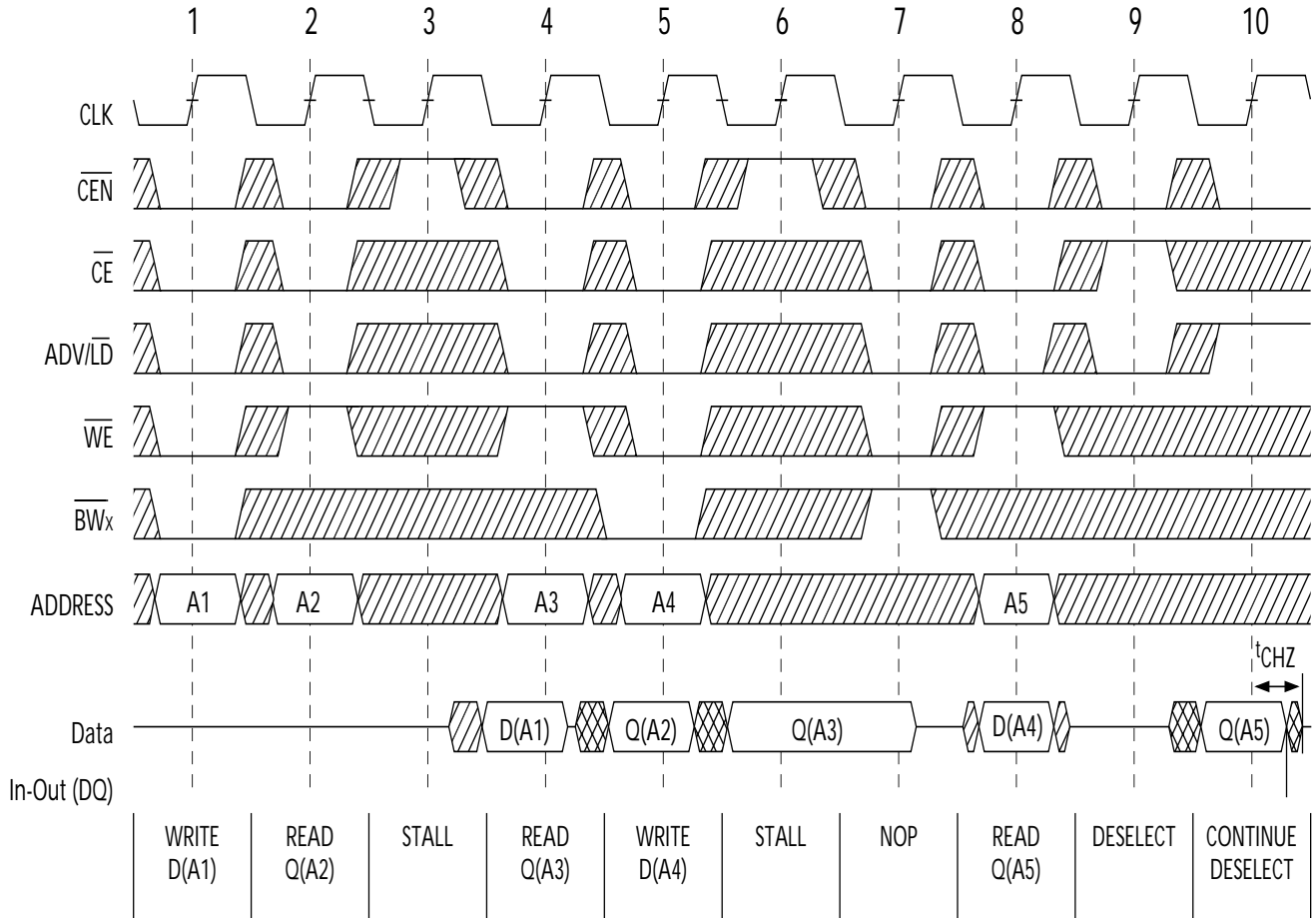
25. Order of the Burst sequence is determined by the status of the MODE (0=Linear, 1=Interleaved). Burst operations are optional.

**Switching Waveforms (continued)**
**NOP, STALL and DESELECT Cycles<sup>[23,24,26]</sup>**

 DON'T CARE    
  UNDEFINED

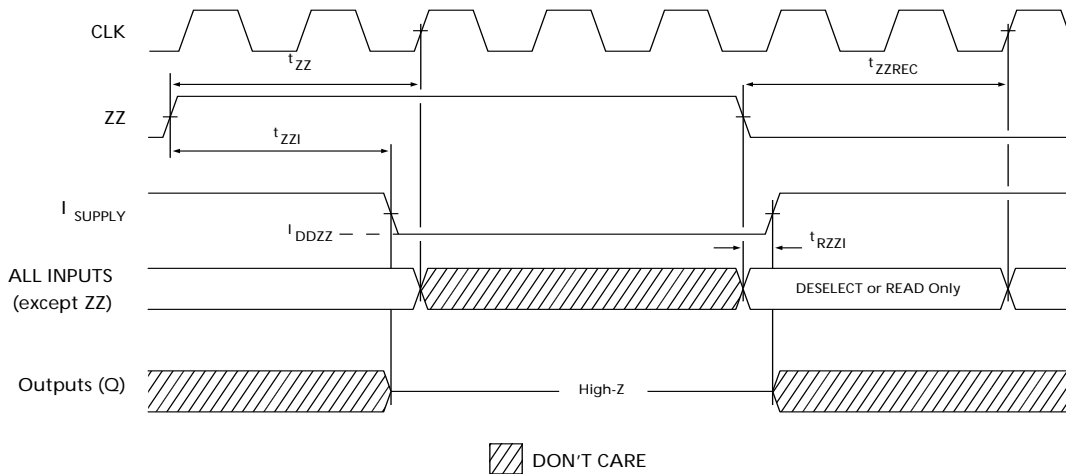
**ZZ Mode Timing<sup>[27,28]</sup>**

**Notes:**

- 26. The IGNORE CLOCK EDGE or STALL cycle (Clock 3) illustrated  $\overline{\text{CEN}}$  being used to create a pause. A write is not performed during this cycle.
- 27. Device must be deselected when entering ZZ mode. See cycle description table for all possible signal conditions to deselect the device.
- 28. I/Os are in High-Z when exiting ZZ sleep mode.

**Ordering Information**

| Speed (MHz)       | Ordering Code     | Package Name   | Package Type  | Operating Range |
|-------------------|-------------------|--|---|-----------------|
| 225               | CY7C1354C-225AXC  | A101   | Lead-Free 100-lead Thin Quad Flat Pack (14 x 20 x 1.4 mm) | Commercial      |
|                   | CY7C1356C-225AXC  |  |   |                 |
|                   | CY7C1354C-225AXI  | A101   | Lead-Free 100-lead Thin Quad Flat Pack (14 x 20 x 1.4 mm) | Industrial      |
|                   | CY7C1356C-225AXI  |  |   |                 |
|                   | CY7C1354C-225BGC  | BG119  | 119-ball Ball Grid Array (14 x 22 x 2.4 mm)               | Commercial      |
|                   | CY7C1356C-225BGC  |  |   |                 |
|                   | CY7C1354C-225BGI  | BG119  | 119-ball Ball Grid Array (14 x 22 x 2.4 mm)               | Industrial      |
|                   | CY7C1356C-225BGI  |  |   |                 |
|                   | CY7C1354C-225BZC  | BB165D   | 165-ball Fine Pitch Ball Grid Array (13 x 15 x 1.4 mm)    | Commercial      |
|                   | CY7C1356C-225BZC  |  |   |                 |
|                   | CY7C1354C-225BZI  | BB165D   | 165-ball Fine Pitch Ball Grid Array (13 x 15 x 1.4 mm)    | Industrial      |
|                   | CY7C1356C-225BZI  |  |   |                 |
|                   | CY7C1354C-225BGXC | BG119  | 119-ball Ball Grid Array (14 x 22 x 2.4 mm)               | Commercial      |
|                   | CY7C1356C-225BGXC |  |   |                 |
|                   | CY7C1354C-225BGXI | BG119  | 119-ball Ball Grid Array (14 x 22 x 2.4 mm)               | Industrial      |
|                   | CY7C1356C-225BGXI |  |   |                 |
|                   | CY7C1354C-225BZXC | BB165D   | 165-ball Fine Pitch Ball Grid Array (13 x 15 x 1.4 mm)    | Commercial      |
|                   | CY7C1356C-225BZXC |  |   |                 |
| CY7C1354C-225BZXI | BB165D            | 165-ball Fine Pitch Ball Grid Array (13 x 15 x 1.4 mm) | Industrial  |                 |
| CY7C1356C-225BZXI |                   |  |   |                 |
| 200               | CY7C1354C-200AXC  | A101   | Lead-Free 100-lead Thin Quad Flat Pack (14 x 20 x 1.4 mm) | Commercial      |
|                   | CY7C1356C-200AXC  |  |   |                 |
|                   | CY7C1354C-200AXI  | A101   | Lead-Free 100-lead Thin Quad Flat Pack (14 x 20 x 1.4 mm) | Industrial      |
|                   | CY7C1356C-200AXI  |  |   |                 |
|                   | CY7C1354C-200BGC  | BG119  | 119-ball Ball Grid Array (14 x 22 x 2.4 mm)               | Commercial      |
|                   | CY7C1356C-200BGC  |  |   |                 |
|                   | CY7C1354C-200BGI  | BG119  | 119-ball Ball Grid Array (14 x 22 x 2.4 mm)               | Industrial      |
|                   | CY7C1356C-200BGI  |  |   |                 |
|                   | CY7C1354C-200BZC  | BB165D   | 165-ball Fine Pitch Ball Grid Array (13 x 15 x 1.4 mm)    | Commercial      |
|                   | CY7C1356C-200BZC  |  |   |                 |
|                   | CY7C1354C-200BZI  | BB165D   | 165-ball Fine Pitch Ball Grid Array (13 x 15 x 1.4 mm)    | Industrial      |
|                   | CY7C1356C-200BZI  |  |   |                 |
|                   | CY7C1354C-200BGXC | BG119  | 119-ball Ball Grid Array (14 x 22 x 2.4 mm)               | Commercial      |
|                   | CY7C1356C-200BGXC |  |   |                 |
|                   | CY7C1354C-200BGXI | BG119  | 119-ball Ball Grid Array (14 x 22 x 2.4 mm)               | Industrial      |
|                   | CY7C1356C-200BGXI |  |   |                 |
|                   | CY7C1354C-200BZXC | BB165D   | 165-ball Fine Pitch Ball Grid Array (13 x 15 x 1.4 mm)    | Commercial      |
|                   | CY7C1356C-200BZXC |  |   |                 |
| CY7C1354C-200BZXI | BB165D            | 165-ball Fine Pitch Ball Grid Array (13 x 15 x 1.4 mm) | Industrial  |                 |
| CY7C1356C-200BZXI |                   |  |   |                 |

**Ordering Information**

| Speed (MHz) | Ordering Code     | Package Name | Package Type  | Operating Range |
|-------------|-------------------|--------------|---|-----------------|
| 166         | CY7C1354C-166AXC  | A101         | Lead-Free 100-lead Thin Quad Flat Pack (14 x 20 x 1.4 mm) | Commercial      |
|             | CY7C1356C-166AXC  |              |   |                 |
|             | CY7C1354C-166AXI  | A101         | Lead-Free 100-lead Thin Quad Flat Pack (14 x 20 x 1.4 mm) | Industrial      |
|             | CY7C1356C-166AXI  |              |   |                 |
|             | CY7C1354C-166BGC  | BG119        | 119-ball Ball Grid Array (14 x 22 x 2.4 mm)               | Commercial      |
|             | CY7C1356C-166BGC  |              |   |                 |
|             | CY7C1354C-166BGI  | BG119        | 119-ball Ball Grid Array (14 x 22 x 2.4 mm)               | Industrial      |
|             | CY7C1356C-166BGI  |              |   |                 |
|             | CY7C1354C-166BZC  | BB165D       | 165-ball Fine Pitch Ball Grid Array (13 x 15 x 1.4 mm)    | Commercial      |
|             | CY7C1356C-166BZC  |              |   |                 |
|             | CY7C1354C-166BZI  | BB165D       | 165-ball Fine Pitch Ball Grid Array (13 x 15 x 1.4 mm)    | Industrial      |
|             | CY7C1356C-166BZI  |              |   |                 |
|             | CY7C1354C-166BGXC | BG119        | 119-ball Ball Grid Array (14 x 22 x 2.4 mm)               | Commercial      |
|             | CY7C1356C-166BGXC |              |   |                 |
|             | CY7C1354C-166BGXI | BG119        | 119-ball Ball Grid Array (14 x 22 x 2.4 mm)               | Industrial      |
|             | CY7C1356C-166BGXI |              |   |                 |
|             | CY7C1354C-166BZXC | BB165D       | 165-ball Fine Pitch Ball Grid Array (13 x 15 x 1.4 mm)    | Commercial      |
|             | CY7C1356C-166BZXC |              |   |                 |
|             | CY7C1354C-166BZXI | BB165D       | 165-ball Fine Pitch Ball Grid Array (13 x 15 x 1.4 mm)    | Industrial      |
|             | CY7C1356C-166BZXI |              |   |                 |

Shaded areas contain advance information. Please contact your local Cypress sales representative for availability of these parts. Lead-free BGX package will be available in 2005.

**Package Diagrams**

**100-Pin Thin Plastic Quad Flatpack (14 x 20 x 1.4 mm) A101**

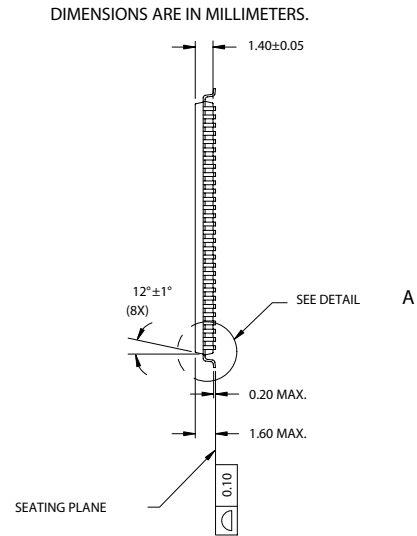
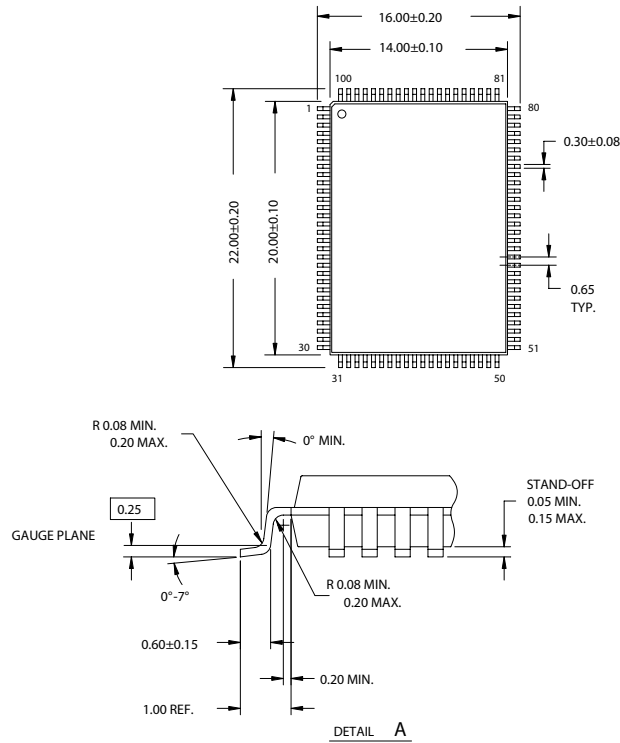

51-85050-\*A



Package Diagrams (continued)

**119-Lead BGA (14 x 22 x 2.4mm) BG119**

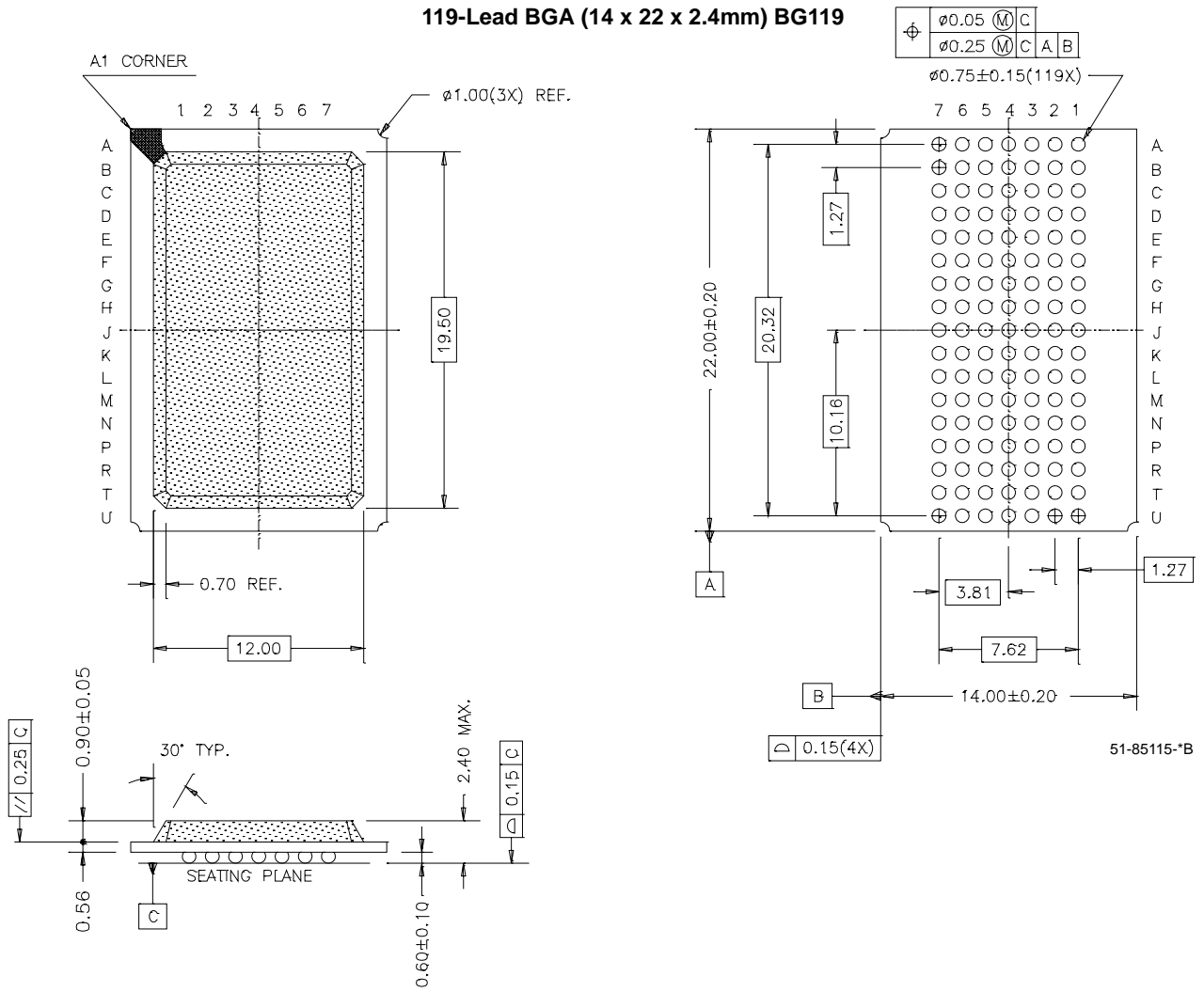

**Package Diagrams** (continued)

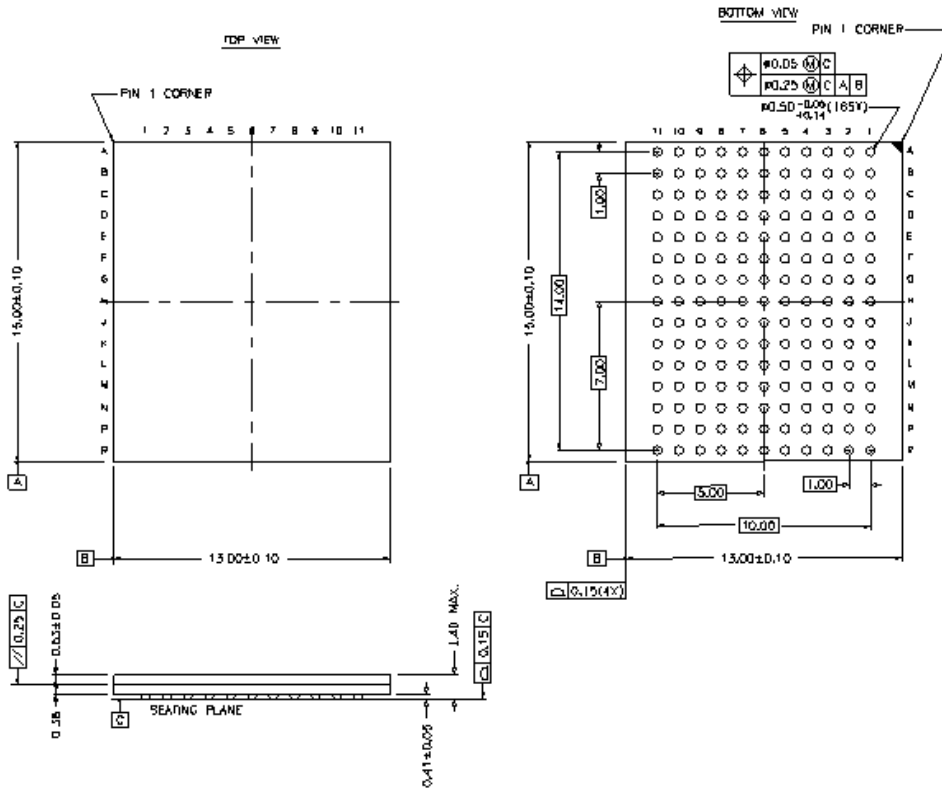
**165 FBGA 13 x 15 x 1.40 MM BB165D**

51-85180-\*\*

NoBL and No Bus Latency are trademarks of Cypress Semiconductor Corporation. ZBT is a trademark of Integrated Device Technology. All product and company names mentioned in this document are the trademarks of their respective holders.



**Document History Page**

| <b>Document Title: CY7C1354C/CY7C1356C 9-Mbit (256K x 36/512K x 18) Pipelined SRAM with NoBL™ Architecture</b> |                |                   |                        |  |
|--|----------------|-------------------|------------------------|--|
| <b>Document Number: 38-05538</b>   |                |                   |                        |  |
| <b>REV.</b>  | <b>ECN No.</b> | <b>Issue Date</b> | <b>Orig. of Change</b> | <b>Description of Change</b>   |
| **   | 242032         | See ECN           | RKF                    | New data sheet   |
| *A   | 278130         | See ECN           | RKF                    | Changed Boundary Scan order to match the B Rev of these devices<br>Changed TQFP pkg to Lead-free TQFP in Ordering Information section<br>Added comment of Lead-free BG and BZ packages availability  |
| *B   | 284431         | See ECN           | VBL                    | Changed ISB1 and ISB3 from DC Characteristic table as follows<br>ISB1: 225 MHz -> 130 mA, 200 MHz -> 120 mA, 167 MHz -> 110 mA<br>ISB3: 225 MHz -> 120 mA, 200 MHz -> 110 mA, 167 MHz -> 100 mA<br>Add BG and BZ pkg lead-free part numbers to ordering info section |