

THIS SKETCH IS FOR QUOTATION PURPOSES ONLY

**FINISH**  
(TICK APPLICABLE):

- 100% TIN
- GOLD

- NOTES:
1. MAXIMUM PERMISSIBLE OUT OF SQUARE OF PIN TO MOULDING TO BE 0.10mm IN ANY DIRECTION.
  2. CONTACT LEG VARIATION ON COMPLETE ASSEMBLY NOT TO EXCEED 0.10mm.

SPECIFICATION:

MATERIAL:  
 MOULDING = HIGH TEMPERATURE NYLON 6T, UL94V-0, BLACK  
 PINS = PHOSPHOR BRONZE  
 FINISH:  
 PINS: SEE BOX  
 ELECTRICAL:  
 CURRENT RATING = 1A MAX  
 CONTACT RESISTANCE = 30 mΩ MAX  
 INSULATION RESISTANCE = 100 MΩ MIN  
 DIELECTRIC STRENGTH = 650V AC/DC  
 ENVIRONMENTAL:  
 TEMPERATURE RANGE = -40°C TO +105°C  
 PACKING:  
 BAG

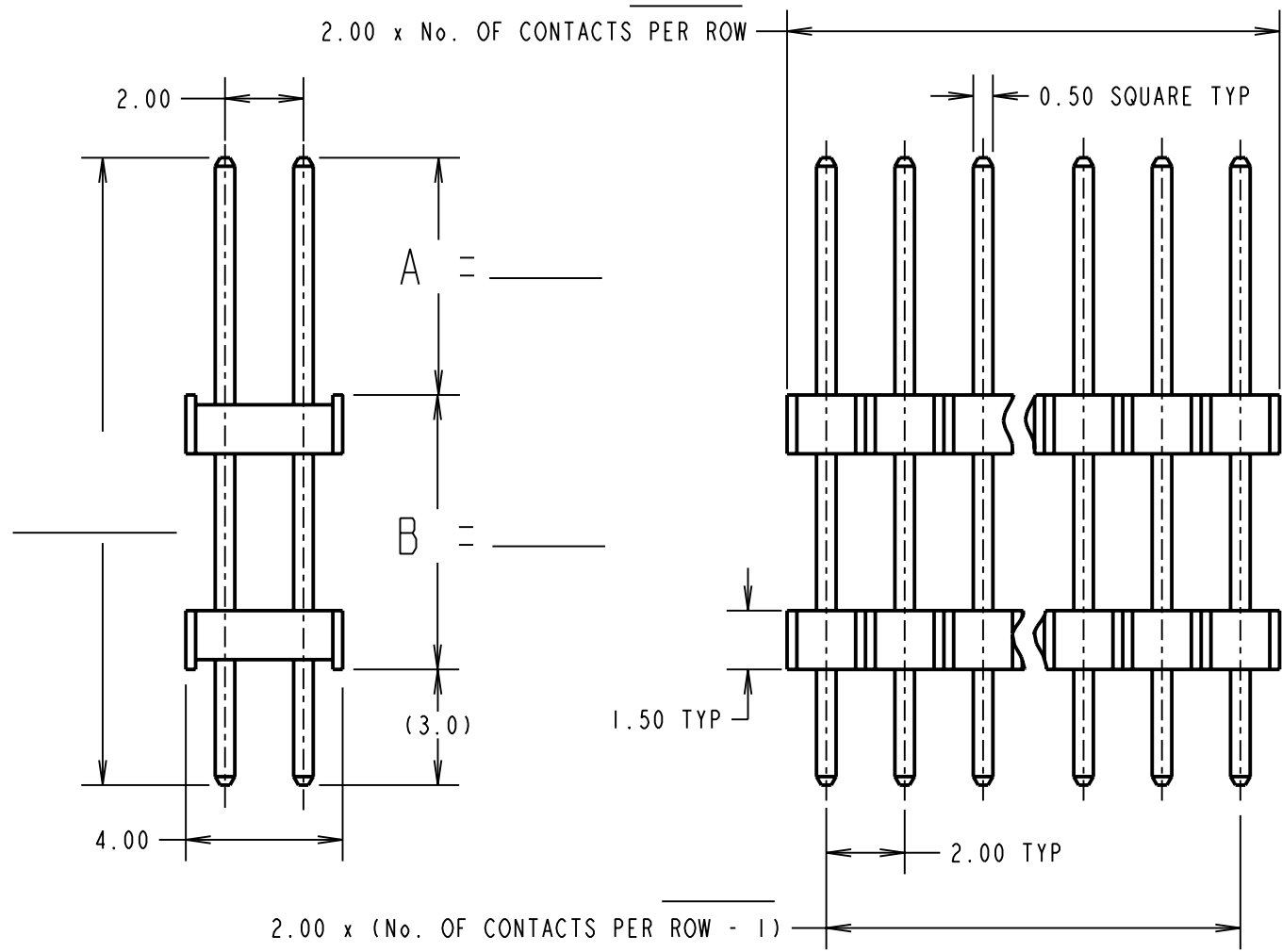

DATE OF SKETCH:

REQUESTED BY:

No. OF CONTACTS PER ROW:



<b>HARWIN INC</b> U.S.A. TEL: (812) 542 2540 FAX: (812) 542 2541	<b>HARWIN PLC</b> U.K. TEL: 023 9231 4545 FAX: 023 9231 4590	<b>HARWIN PTE</b> SINGAPORE TEL: 65 6779 4909 FAX: 65 6779 3868
---	---	--

THIS DRAWING AND ANY INFORMATION OR DESCRIPTIVE MATTER SET OUT HEREON ARE CONFIDENTIAL AND COPYRIGHT PROPERTY OF THE HARWIN GROUP AND MUST NOT BE DISCLOSED, LOANED, COPIED OR USED FOR MANUFACTURING, TENDERING OR FOR ANY OTHER PURPOSE WITHOUT THEIR WRITTEN PERMISSION.

**TOLERANCES**  
 X. = ±1mm  
 X.X = ±0.25mm  
 X.XX = ±0.10mm  
 X.XXX = ±0.01mm  
 ANGLES = ±5°  
 UNLESS STATED

**TITLE:**  
 2.00mm PITCH DIL EXTENDED  
 PC TAIL PIN HEADER VARIANT

**DRAWING No.:**  
 M22 - \_\_\_\_\_ F \_\_\_\_\_

SHT  
1  
OF  
1