

8Kx8 Static RAM
CMOS, High Speed
Monolithic

The EDI8808CB is a 65,536bit, high speed CMOS Static RAM organized as 8Kx8.

All inputs and outputs are TTL compatible and allow for direct interfacing with common system bus architecture while operating from a single 5V supply.

Military product compliant to MIL-STD-883, paragraph 1.2.1 is available.

ADVANCE INFORMATION

Features

64K bit CMOS Static

Random Access Memory

- Access Times 20, 25, 35, and 45ns
- Inputs and Outputs Directly TTL Compatible

Jedec Approved Pinouts

- 28 Pin Ceramic Dual-in-line Packages
CERDIP 600 mils Wide, No. 70
Sidebraced, 300 mils Wide, No. 2
- 32 Pin Ceramic LCC, No. 12
- 28 Lead Flatpack, No. 79

Single +5V (±10%) Supply Operation

Pin Configurations
and Block Diagram

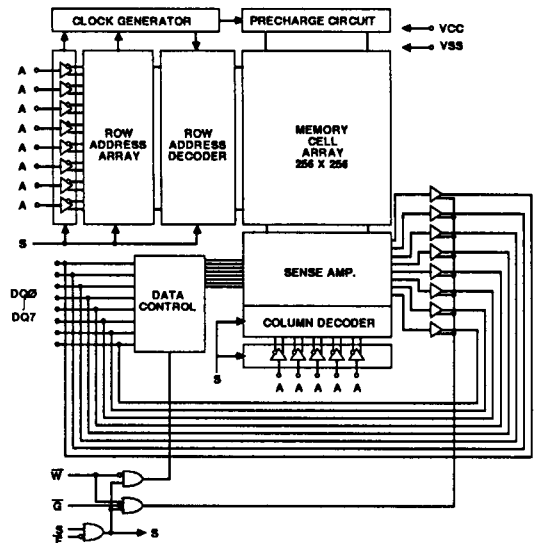
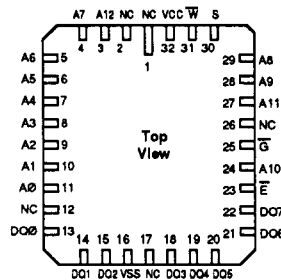
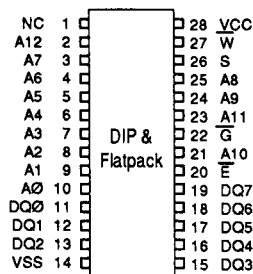

Pin Names

A0-A12	Address Inputs
E	Chip Enable
S	Chip Select
W	Write Enable
G	Output Enable
DQ0-DQ7	Data Input/Output
VCC	Power (+5V±10%)
VSS	Ground
NC	No Connection