

GD54/74HC174, GD54/74HCT174

HEX D-TYPE FLIP-FLOPS WITH COMMON CLOCK & CLEAR

General Description

These devices are identical in pinout to the 54/74LS174. They contain six D-type flip-flops with common clock and clear inputs. Data on the D inputs having the specified setup and hold times are transferred to the outputs on the rising edge of the clock pulse. Clear is asynchronous and active-low. The clear input when low, sets all outputs to a low state. These devices are characterized for operation over wide temperature ranges to meet industry and military specifications.

Features

- Low Power consumption characteristic of CMOS devices
- Output drive capability: 10 LS TTL Loads Min.
- Operating speed superior to LS TTL
- Wide operating voltage range: for HC 2 to 6 volts
for HCT 4.5 to 5.5 volts
- Low input current: 1 μ A Max.
- Low quiescent current: 80 μ A Max. (74HC)
- High noise immunity characteristic of CMOS
- Diode protection on all inputs

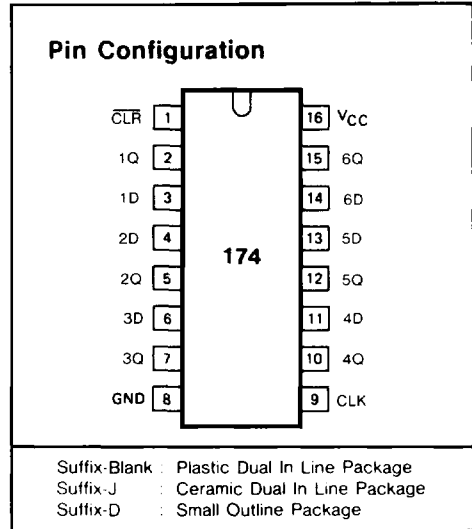

Function Table

OPERATING MODES	INPUTS			OUTPUTS
	$\overline{\text{CLR}}$	CLK	nD	nQ
clear	L	X	X	L
load "1"	H	↑	h	H
load "0"	H	↑	l	L

H = HIGH voltage level
 h = HIGH voltage level one set-up time prior to the LOW-to-HIGH CLK transition
 L = LOW voltage level
 l = LOW voltage level one set-up time prior to the LOW-to-HIGH CLK transition
 X = don't care
 ↑ = LOW-to-HIGH CLK transition

Absolute Maximum Ratings

SYMBOL	PARAMETER	CONDITIONS	MIN.	MAX.	UNIT
V_{CC}	DC Supply voltage		-0.5	+7	V
I_{IK}, I_{OK}	DC input or output diode current	for $V_i < -0.5$ or $V_i > V_{CC} + 0.5V$		20	mA
I_O	DC output source or sink current	for $-0.5V < V_o < V_{CC} + 0.5V$		25	mA
I_{CC}	DC V_{CC} or GND current			50	mA
T_{stg}	Storage temperature range		-65	150	°C
P_D	Power dissipation per package	above +70°C: derate linearly with 8mW/K		500	mW
T_L	Lead temperature	At distance 1/16 ± 1/32 in. from case for 60 sec(CERAMIC) 10 sec(PLASTIC)		300 260	°C

Recommended Operating Conditions

CHARACTERISTIC	LIMITS		UNITS
	MIN.	MAX.	
Supply-Voltage Range V_{CC} : GD54/74HC Types GD54/74HCT Types	2 4.5	6 5.5	V
DC Input or Output Voltage V_i, V_o	0	V_{CC}	V
Operating Temperature T_A : GD74 Types GD54 Types	-40 -55	+85 +125	°C
Input Rise and Fall times t_r, t_f : GD54/74HC Types at 2V at 4.5V at 6V GD54/74HCT Types at 4.5 V		1000 500 400 500	ns

Logic Diagram

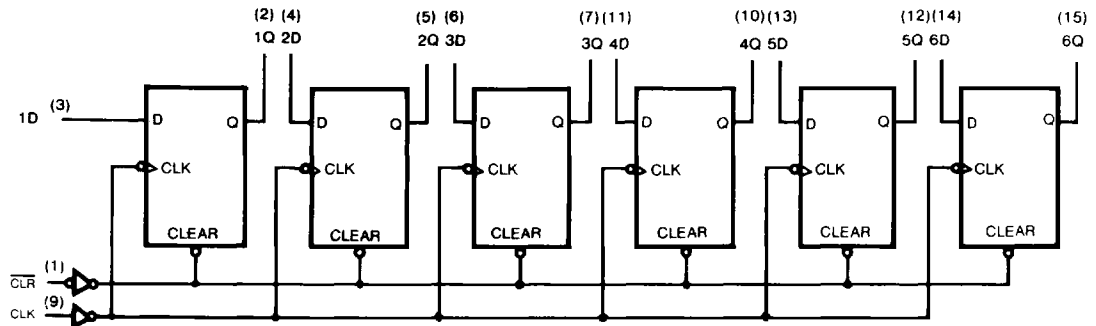

Fig. 1 Logic diagram

DC Electrical Characteristics for HC

SYMBOL	PARAMETER	TEST CONDITION	V _{CC} (V)	T _A =25°C			GD74HC174		GD54HC174		UNIT
				MIN.	TYP.	MAX.	MIN.	MAX.	MIN.	MAX.	
V _{IH}	HIGH level input Voltage		2.0	1.5			1.5		1.5		V
			4.5	3.15		3.15		3.15			
			6.0	4.2		4.2		4.2			
V _{IL}	LOW level input voltage		2.0			0.3		0.3		0.3	V
			4.5			0.9		0.9		0.9	
			6.0			1.2		1.2		1.2	
V _{OH}	HIGH level output voltage	V _{IN} =V _{IH}	I _{OH} =-20μA	2.0	1.9	2.0		1.9		1.9	V
				4.5	4.4	4.5		4.4		4.4	
	or V _{IL}	I _{OH} =-4mA I _{OH} =-5.2mA	2.0								
			4.5	3.98	4.3		3.84		3.7		
			6.0	5.48	5.2		5.34		5.2		
V _{OL}	LOW level output voltage	V _{IN} =V _{IH}	I _{OL} =20μA	2.0			0.1		0.1	V	
				4.5			0.1		0.1		
	or V _{IL}	I _{OL} =4mA I _{OL} =5.2mA	2.0			0.1		0.1	0.1		
			4.5		0.17	0.26		0.33	0.4		
			6.0		0.15	0.26		0.33	0.4		
I _{IN}	Input leakage Current	V _{IN} =V _{CC} or GND	6.0			0.1		1.0		μA	
I _{CC}	Quiescent Supply Current	V _{IN} =V _{CC} or GND I _{out} =0μA	6.0			8		80	160	μA	

DC Electrical Characteristics for HCT

SYMBOL	PARAMETER	TEST CONDITION	V _{CC} (V)	T _A =25°C			GD74HCT174		GD54HCT174		UNIT
				MIN.	TYP.	MAX.	MIN.	MAX.	MIN.	MAX.	
V _{IH}	HIGH level input Voltage		4.5 to 5.5	2.0			2.0		2.0		V
V _{IL}	LOW level input voltage		4.5 to 5.5			0.8		0.8		0.8	V
V _{OH}	HIGH level output voltage	V _{IN} =V _{IH}	I _{OH} =-20μA	4.5	4.4	4.5		4.4		4.4	V
				4.5	3.98	4.3		3.84		3.7	
		or V _{IL}	I _{OH} =-4mA	4.5							
				4.5							
V _{OL}	LOW level output voltage	V _{IN} =V _{IH}	I _{OL} =20μA	4.5			0.1		0.1	0.1	V
				4.5		0.17	0.26		0.33	0.4	
		or V _{IL}	I _{OL} =4mA	4.5							
				4.5							
I _{IN}	Input leakage Current	V _{IN} =V _{CC} or GND	5.5			0.1		1.0		μA	
I _{CC}	Quiescent Supply Current	V _{IN} =V _{CC} or GND I _{out} =0μA	5.5			8		80	160	μA	

GD54/74HC174, GD54/74HCT174

Timing Requirements for HC: $t_r=t_f=6\text{ns}$ $C_L=50\text{ pF}$

SYMBOL	PARAMETER		V _{CC} (V)	T _A =25°C			GD74HC174		GD54HC174		UNIT
				MIN.	TYP.	MAX.	MIN.	MAX.	MIN.	MAX.	
t _w	Pulse width	CL \bar{R}	2.0	80	30		100		120		ns
			4.5	16	10		20		25		
			6.0	14	8		18		22		
		CLK	2.0	80	30		100		120		ns
			4.5	16	10		20		25		
			6.0	14	8		18		22		
t _{su}	Setup time	Data to CLK	2.0	60	30		80		100		ns
			4.5	15	10		18		22		
			6.0	14	8		16		18		
t _{rec}	Recovery time	PR or CL \bar{R} to CLK	2.0	5	0		5		5		ns
			4.5	5	0		5		5		
			6.0	5	0		5		5		
t _h	Hold time	CLK to Data	2.0	3	0		3		3		ns
			4.5	3	0		3		3		
			6.0	3	0		3		3		

AC Characteristics for HC: $t_r=t_f=6\text{ns}$ $C_L=50\text{ pF}$

SYMBOL	PARAMETER		V _{CC} (V)	T _A =25°C			GD74HC174		GD54HC174		UNIT
				MIN.	TYP.	MAX.	MIN.	MAX.	MIN.	MAX.	
f _{max}	Maximum Clock Pulse Frequency	2.0	6	20		5		4		MHz	
		4.5	30	65		25		20			
		6.0	35	75		30		25			
t _{PLH} / t _{PHL}	Propagation Delay Time CLK to nQ.	2.0		46	160		200		250	ns	
		4.5		15	30		40		50		
		6.0		14	28		35		45		
t _{PLH} / t _{PHL}	Propagation Delay Time CL \bar{R} to nQ.	2.0		45	155		190		230	ns	
		4.5		15	28		38		45		
		6.0		14	26		34		40		
t _{TLH} / t _{THL}	Output Transition Time	2.0		25	70		85		100	ns	
		4.5		8	15		18		22		
		6.0		7	13		16		19		

GD54/74HC174, GD54/74HCT174

Timing Requirements for HCT: $t_r=t_f=6\text{ns}$ $C_L=50\text{ pF}$

SYMBOL	PARAMETER		V _{CC} (V)	T _A =25°C			GD74HCT174		GD54HCT174		UNIT
				MIN.	TYP.	MAX.	MIN.	MAX.	MIN.	MAX.	
t _w	Pulse width	$\overline{\text{CLR}}$	4.5	18	10		20		25		ns
		CLK	4.5	10	10		20		25		ns
t _{su}	Setup time	Data to CLK	4.5	15	10		18		20		ns
t _{rec}	Recovery time	$\overline{\text{PR}}$ or $\overline{\text{CLR}}$ to CLK	4.5	5	0		5		5		ns
t _h	Hold time	CLK to Data	4.5	3	0		3		3		ns

AC Characteristics for HCT: $t_r=t_f=6\text{ns}$ $C_L=50\text{ pF}$

SYMBOL	PARAMETER		V _{CC} (V)	T _A =25°C			GD74HCT174		GD54HCT174		UNIT
				MIN.	TYP.	MAX.	MIN.	MAX.	MIN.	MAX.	
f _{max}	Maximum Clock Pulse Frequency		4.5	27	54		22		18		MHz
t _{PLH} / t _{PHL}	Propagation Delay time CLK to nQ		4.5		16	30		40		50	ns
t _{PLH} / t _{PHL}	Propagation Delay time $\overline{\text{CLR}}$ to nQ		4.5		16	30		40		50	ns
t _{TLH} / t _{THL}	Output Transition time		4.5		8	15		18		22	ns

AC Waveforms

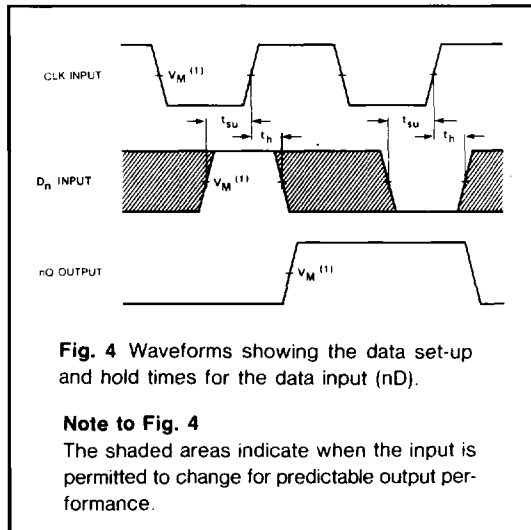
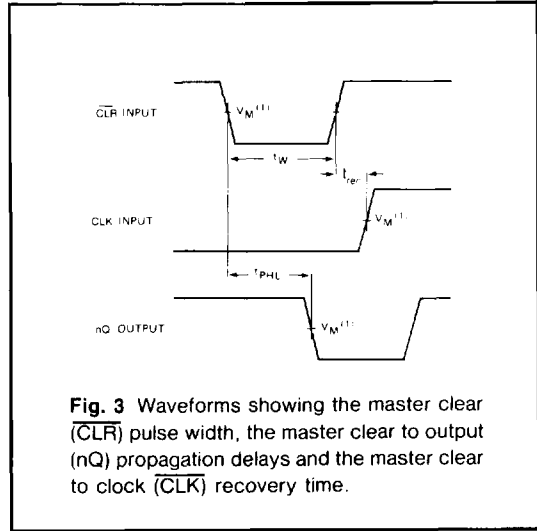
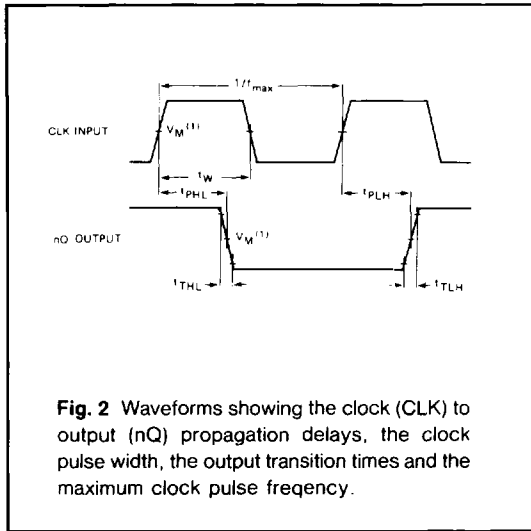

Note to AC waveforms
(1) HC : $V_M = 50\%$; $V_I = \text{GND to } V_{CC}$.
HCT : $V_M = 1.3V$; $V_I = \text{GND to } 3V$.