

SKFM620C-D THRU SKFM6200C-D

List

List..... 1

Package outline..... 2

Features..... 2

Mechanical data..... 2

Maximum ratings 2

Rating and characteristic curves..... 3

Pinning information..... 4

Marking..... 4

Suggested solder pad layout..... 4

Packing information..... 5

Reel packing..... 6

Suggested thermal profiles for soldering processes..... 6

High reliability test capabilities..... 7

SKFM620C-D THRU SKFM6200C-D

6.0A Surface Mount Schottky Barrier Rectifiers - 20V-200V

Features

- Batch process design, excellent power dissipation offers better reverse leakage current and thermal resistance.
- Low power loss, high efficiency.
- High current capability, low forward voltage drop.
- High surge capability.
- Guardring for overvoltage protection.
- Ultra high-speed switching.
- Silicon epitaxial planar chip, metal silicon junction.
- Lead-free parts meet environmental standards of MIL-STD-19500 /228
- Suffix "-H" indicates Halogen-free part, ex.SKFM620C-D-H.

Mechanical data

- Epoxy:UL94-V0 rated flame retardant
- Case : Molded plastic, TO-252 / DPAK
- Terminals : Solder plated, solderable per MIL-STD-750, Method 2026
- Mounting Position : Any
- Weight : Approximated 0.34 gram

Package outline

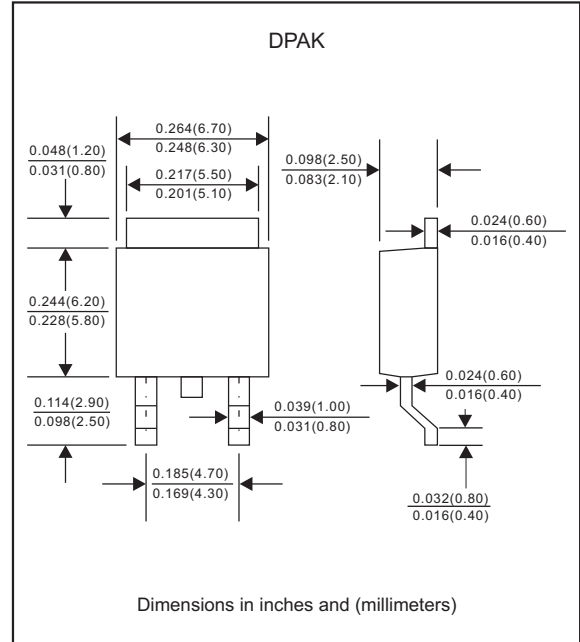

Maximum ratings and Electrical Characteristics (AT T_A=25°C unless otherwise noted)

PARAMETER	CONDITIONS	Symbol	MIN.	TYP.	MAX.	UNIT
Forward rectified current	See Fig.1	I _O			6.0	A
Forward surge current	8.3ms single half sine-wave (JEDEC methode)	I _{FSM}			75	A
Reverse current	V _R = V _{RRM} T _J = 25°C	I _R			0.5	mA
	V _R = V _{RRM} T _J = 100°C				20	
Typical thermal resistance	Junction to ambient	R _{θJA}		41		°C/W
	Junction to case	R _{θJC}		24		°C/W
Diode junction capacitance	f=1MHz and applied 4V DC reverse voltage	C _J		250		pF
Storage temperature		T _{STG}	-65		+175	°C

SYMBOLS	V _{RRM} *1 (V)	V _{RMS} *2 (V)	V _R *3 (V)	V _F *4 (V)	Operating temperature T _J , (°C)
SKFM620C-D	20	14	20	0.55	-55 to +125
SKFM630C-D	30	21	30		
SKFM640C-D	40	28	40		
SKFM645C-D	45	31.5	45		
SKFM650C-D	50	35	50	0.70	-55 to +150
SKFM660C-D	60	42	60		
SKFM680C-D	80	56	80	0.85	
SKFM6100C-D	100	70	100		
SKFM6150C-D	150	105	150	0.90	
SKFM6200C-D	200	140	200	0.92	

- *1 Repetitive peak reverse voltage
- *2 RMS voltage
- *3 Continuous reverse voltage
- *4 Maximum forward voltage@ I_F = 3.0A

Rating and characteristic curves (SKFM620C-D THRU SKFM6200C-D)

FIG.1-TYPICAL FORWARD CURRENT DERATING CURVE

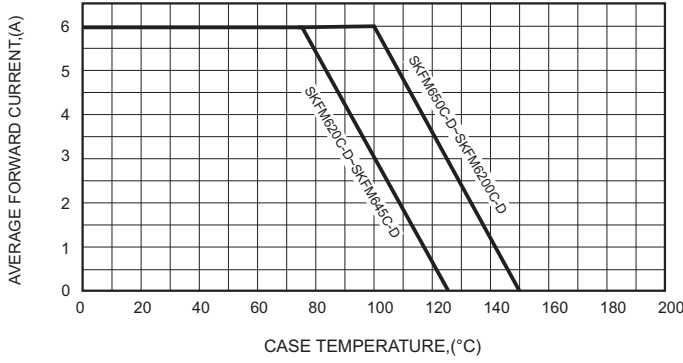

FIG.2-TYPICAL FORWARD CHARACTERISTICS

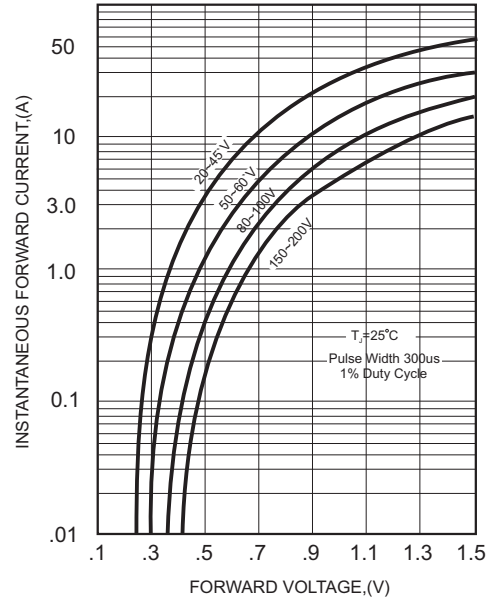

FIG.3-MAXIMUM NON-REPETITIVE FORWARD SURGE CURRENT

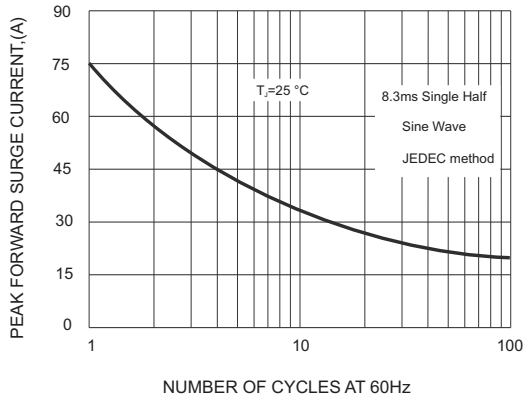

FIG.4 - TYPICAL REVERSE CHARACTERISTICS

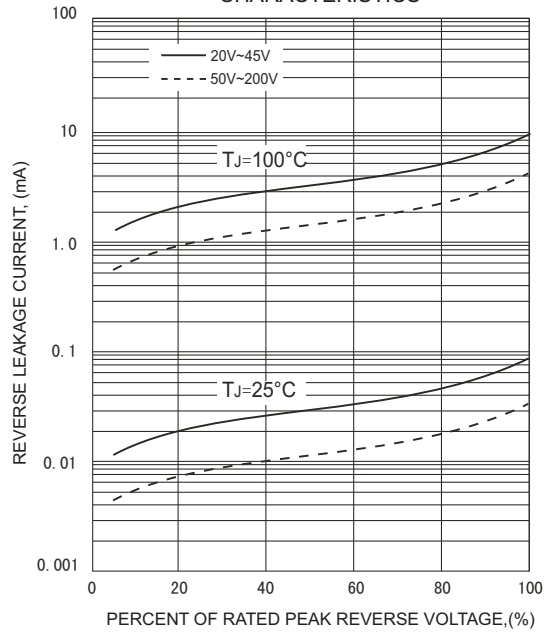
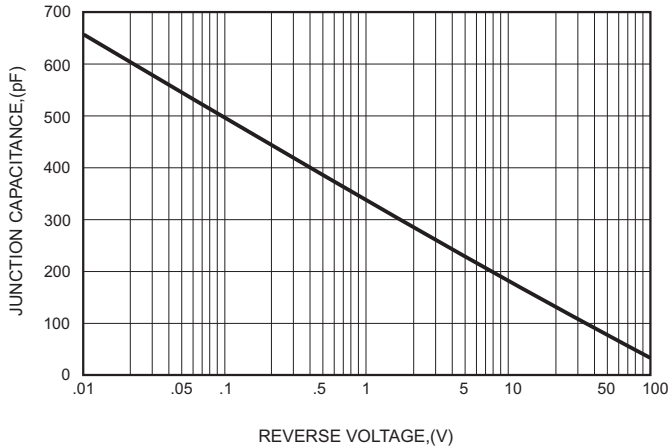
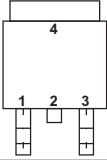
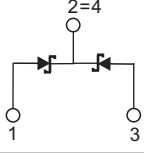

FIG.5-TYPICAL JUNCTION CAPACITANCE



SKFM620C-D THRU SKFM6200C-D

Pinning information

Simplified outline	Symbol
	

Marking

Type number	Marking code
SKFM620C-D	SK620
SKFM630C-D	SK630
SKFM640C-D	SK640
SKFM645C-D	SK640
SKFM650C-D	SK650
SKFM660C-D	SK660
SKFM680C-D	SK680
SKFM6100C-D	SK6100
SKFM6150C-D	SK6150
SKFM6200C-D	SK6200

Suggested solder pad layout

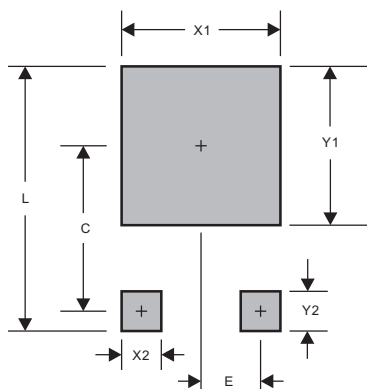

PACKAGE	DPAK
C	0.272(6.90)
E	0.091(2.30)
L	0.457(11.60)
X1	0.276(7.00)
X2	0.059(1.50)
Y1	0.276(7.00)
Y2	0.098(2.50)

Dimensions in inches and (millimeters)

SKFM620C-D THRU SKFM6200C-D

Packing information

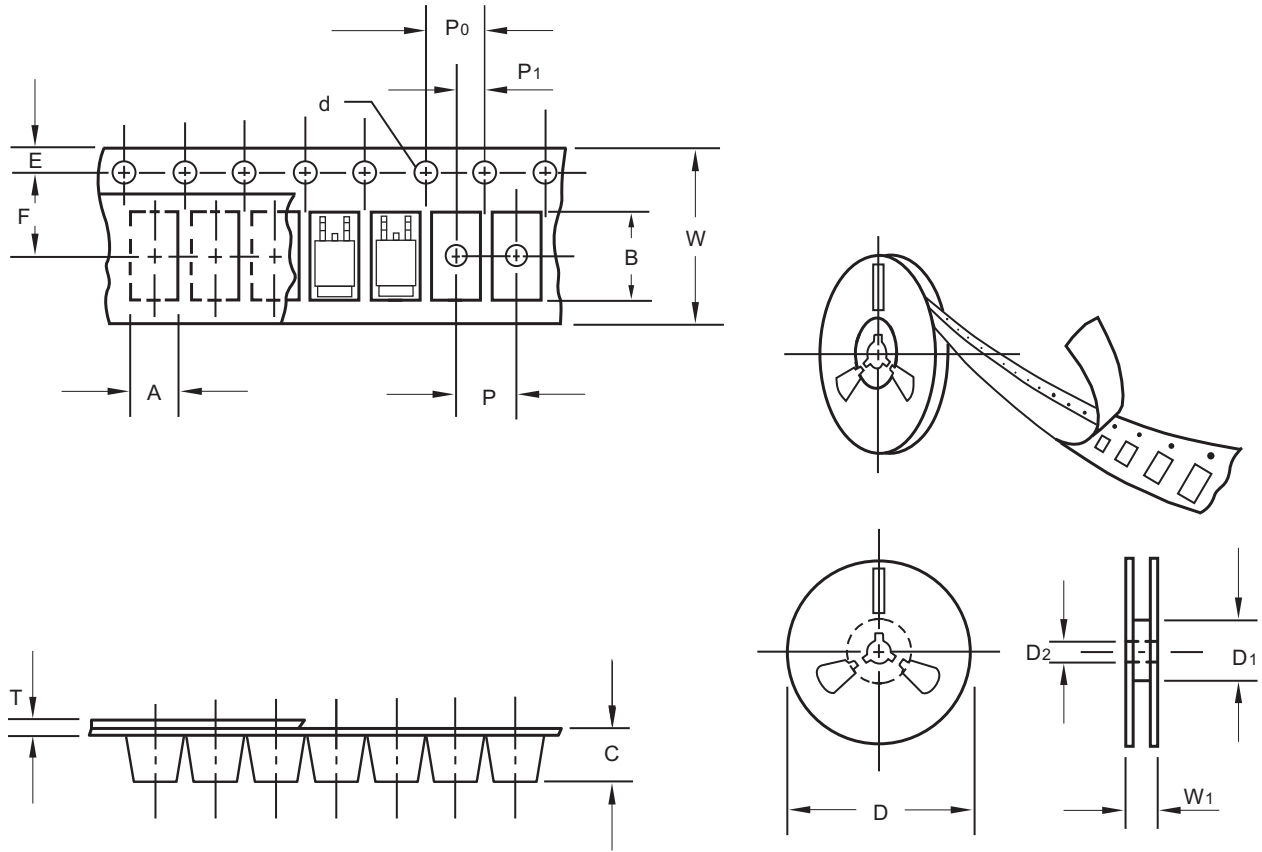

unit:mm

Item	Symbol	Tolerance	DPAK
Carrier width	A	0.1	6.90
Carrier length	B	0.1	10.50
Carrier depth	C	0.1	2.70
Sprocket hole	d	0.1	1.50
13" Reel outside diameter	D	2.0	330.00
13" Reel inner diameter	D1	min	50.00
7" Reel outside diameter	D	2.0	-
7" Reel inner diameter	D1	min	-
Feed hole diameter	D2	0.5	13.00
Sprocket hole position	E	0.1	1.75
Punch hole position	F	0.1	7.50
Punch hole pitch	P	0.1	8.00
Sprocket hole pitch	P0	0.1	4.00
Embossment center	P1	0.1	2.00
Overall tape thickness	T	0.1	0.23
Tape width	W	0.3	16.00
Reel width	W1	1.0	22.00

Note: Devices are packed in accordance with EIA standard RS-481-A and specifications listed above.

SKFM620C-D THRU SKFM6200C-D

Reel packing

PACKAGE	REEL SIZE	REEL (pcs)	COMPONENT SPACING (m/m)	BOX (pcs)	INNER BOX (m/m)	REEL DIA, (m/m)	CARTON SIZE (m/m)	CARTON (pcs)	APPROX. GROSS WEIGHT (kg)
DPAK/TO-252	13"	3,000	8.0	6,000	335*335*43	330	350*330*360	48,000	22.0

Suggested thermal profiles for soldering processes

- 1.Storage environment: Temperature=5°C~40°C Humidity=55%±25%
- 2.Reflow soldering of surface-mount devices

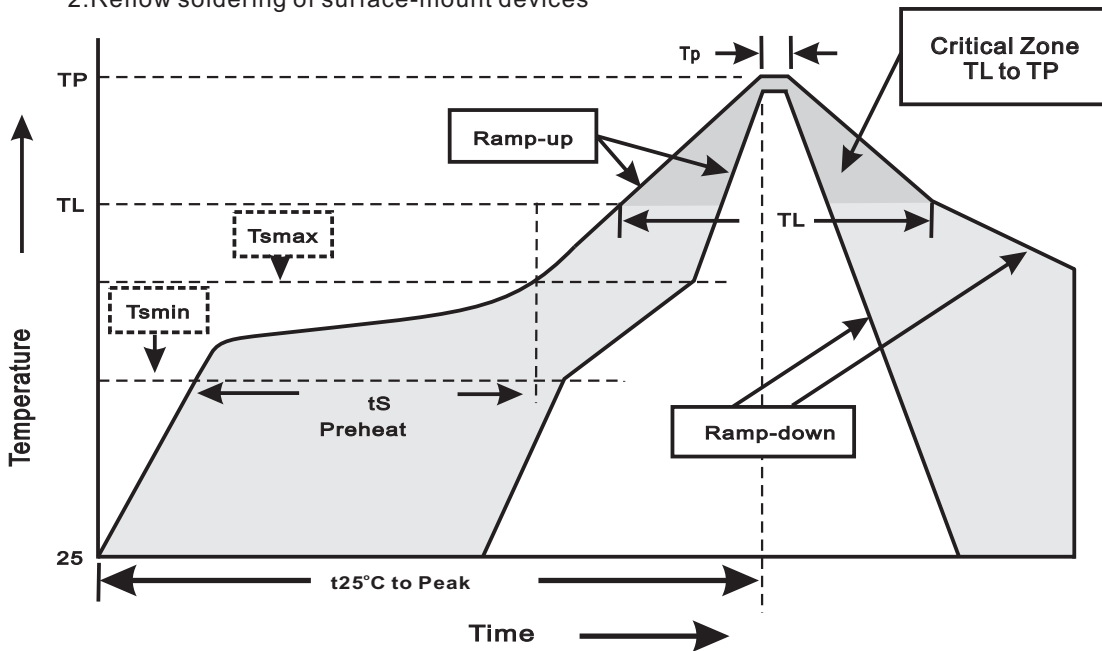

3.Reflow soldering

Profile Feature	Soldering Condition
Average ramp-up rate(T _L to T _P)	<3°C/sec
Preheat -Temperature Min(T _{smin}) -Temperature Max(T _{smax}) -Time(min to max)(t _s)	150°C 200°C 60~120sec
T _{smax} to T _L -Ramp-upRate	<3°C/sec
Time maintained above: -Temperature(T _L) -Time(t _L)	217°C 60~260sec
Peak Temperature(T _P)	255°C-0/+5°C
Time within 5°C of actual Peak Temperature(t _P)	10~30sec
Ramp-down Rate	<3°C/sec
Time 25°C to Peak Temperature	<6minutes

SKFM620C-D THRU SKFM6200C-D**High reliability test capabilities**

Item Test	Conditions	Reference
1. Solder Resistance	at $260\pm 5^{\circ}\text{C}$ for $10\pm 2\text{sec}$. immerse body into solder $1/16''\pm 1/32''$	MIL-STD-750D METHOD-2031
2. Solderability	at $245\pm 5^{\circ}\text{C}$ for 5 sec.	MIL-STD-202F METHOD-208
3. High Temperature Reverse Bias	$V_R=80\%$ rate at $T_J=125^{\circ}\text{C}$ for 168 hrs.	MIL-STD-750D METHOD-1038
4. Forward Operation Life	Rated average rectifier current at $T_A=25^{\circ}\text{C}$ for 500hrs.	MIL-STD-750D METHOD-1027
5. Intermittent Operation Life	$T_A = 25^{\circ}\text{C}$, $I_F = I_O$ On state: power on for 5 min. off state: power off for 5 min. on and off for 500 cycles.	MIL-STD-750D METHOD-1036
6. Pressure Cooker	$15P_{SIG}$ at $T_A=121^{\circ}\text{C}$ for 4 hrs.	JESD22-A102
7. Temperature Cycling	-55°C to $+125^{\circ}\text{C}$ dwelled for 30 min. and transferred for 5min. total 10 cycles.	MIL-STD-750D METHOD-1051
8. Forward Surge	8.3ms single half sine-wave , one surge.	MIL-STD-750D METHOD-4066-2
9. Humidity	at $T_A=85^{\circ}\text{C}$, RH=85% for 1000hrs.	MIL-STD-750D METHOD-1021
10. High Temperature Storage Life	at 175°C for 1000 hrs.	MIL-STD-750D METHOD-1031