

STRUCTURE Silicon Monolithic Integrated Circuit
TYPE Step down DC/DC converter controller for Laptop PC

PRODUCT SERIES
FEATURES

BD9526AMUV

- Built in 2ch H³REG DC/DC converter controller
- The Light load mode efficiency is improved by SLLM (Simple Light Load Mode)
- Adjustable Switching Frequency (f=200kHz~500kHz)
- Built in 3ch Linear Regulator

○Absolute Maximum ratings (Ta=25°C)

Parameter	Symbol	Limits	Unit
Terminal voltage	VIN1, VIN2, CTL	30 ^{*1*2}	V
	EXTVCC, FB1, FB2, Is+1, Is+2, MCTL	7 ^{*1*2}	V
	FS1, FS2, REF1, REF2, LG1, LG2, TEST1, TEST2	INTVCC+0.3 ^{*1*2}	V
	BOOT1, BOOT2	35 ^{*1*2}	V
	BOOT1-SW1, BOOT2-SW2, HG1-SW1, HG2-SW2	7 ^{*1*2}	V
	HG1	BOOT1+0.3 ^{*1*2}	V
	HG2	BOOT2+0.3 ^{*1*2}	V
	EN1, EN2	6 ^{*1*2}	V
	DGND, PGND1, PGND2	AGND±0.3 ^{*1*2}	V
Power dissipation 1	Pd1	0.38 ^{*3}	W
Power dissipation 2	Pd2	0.88 ^{*4}	W
Power dissipation 3	Pd3	2.06 ^{*5}	W
Power dissipation 4	Pd4	4.56 ^{*6}	W
Operating temperature range	Topr	-10~+100	°C
Storage temperature range	Tstg	-55~+150	°C
Junction Temperature	Tjmax	+150	°C

*1 Do not however exceed Pd.

*2 Instantaneous surge voltage, back electromotive force and voltage under less than 10% duty cycle.

*3 Reduced by 3.0mW for each increase in Ta of 1°C over 25°C (when don't mounted on a heat radiation board)

*4 Reduced by 7.0mW for increase in Ta of 1°C over 25°C. (when mounted on a board 70.0mm×70mm×1.6mm Glass-epoxy PCB which has 1 layer. (Copper foil area : 0mm²))

*5 Reduced by 16.5mW for increase in Ta of 1°C over 25°C. (when mounted on a board 70.0mm×70mm×1.6mm Glass-epoxy PCB which has 4 layers. (1st and 4th copper foil area : 20.2mm², 2nd and 3rd copper foil area : 5505mm²))

*6 Reduced by 36.5mW for increase in Ta of 1°C over 25°C. (when mounted on a board 70.0mm×70mm×1.6mm Glass-epoxy PCB which has 4 layers. (All copper foil area : 5505mm²))

○Operating supply voltage range (Ta=25°C)

Parameter	Symbol	MIN.	MAX.	Unit
Terminal voltage	VIN1, VIN2	7	25	V
	EXTVCC	4.5	5.5	V
	CTL	-0.3	25	V
	EN1, EN2	-0.3	5.5	V
	BOOT1, BOOT2	4.5	30	V
	BOOT1-SW1, BOOT2-SW2, HG1-SW1, HG2-SW2	-0.3	5.5	V
	REF1, REF2	1	2.75	V
	Is+1, Is+ 2, FB1, FB2	1.9	5.6	V
	MCTL	-0.3	INTVCC+0.3	V

★ This product is not designed for protection against radioactive rays.

Status of this document

The Japanese version of this document is the official specification.

This translated version is intended only as a reference, to aid in understanding the official version.

If there are any differences between the original and translated versions of this document, the official Japanese language version takes priority.

○Electrical characteristics (unless otherwise noted, Ta=25°C VIN1=VIN2=12V, CTL=5V, EN1=EN2=5V, REF1=2.5V, REF2=1.65V, RFS1=RFS2=51kΩ)

Parameter	Symbol	Limit			Unit	Condition
		Min.	Typ.	Max.		
VIN1 Bias Current	IIN1	-	130	200	μA	CTL=5V
VIN2 Bias Current 1	IIN2_1	-	100	150	μA	CTL=5V, EN1=EN2=0V
VIN2 Bias Current 2	IIN2_2	-	20	40	μA	CTL=5V, EN1=EN2=0V,EXTVCC=5V
VIN1 Shutdown Current	ISHD1	-	0	10	μA	CTL=0V
VIN2 Shutdown Current	ISHD2	-	0	10	μA	CTL=0V
CTL Low Voltage	VCTLL	-0.3	-	0.8	V	
CTL High Voltage	VCTLH	2.3	-	25	V	
CTL Bias Current	ICTL	-	1	3	μA	VCTL=5V
EN Low Voltage	VENL	-0.3	-	0.8	V	
EN High Voltage	VENH	2.3	-	5.5	V	
EN Bias Current	IEN	-	1	3	μA	VEN=3V
[5V Linear Regulator]						
INTVCC output Voltage	VINTVCC	4.90	5.00	5.10	V	IINTVCC1=1mA
INTVCC Maximum Current	IINTVCC	200	-	-	mA	IREG2=0mA
INTVCC Line regulation	Reg.IINT	-	-	180	mV	VIN=7.5 to 25V
INTVCC Load regulation	Reg.LINT	-	-	50	mV	IINTVCC=0 to 30mA
[3.3V Linear Regulator]						
REG1 Output Voltage	VREG1	3.27	3.30	3.33	V	IREG1=1mA
REG1Maximum Current	IREG1	100	-	-	mA	
REG1Line regulation	Reg.I1	-	-	33	mV	VIN=7.5 to 25V
REG1Load regulation	Reg.L1	-	-	33	mV	IREG1=0 to 50mA
REG2 Output Voltage	VREG2	3.27	3.30	3.33	V	IREG2=1mA
REG2Maximum Current	IREG2	100	-	-	mA	
REG2Line regulation	Reg.I2	-	-	20	mV	VIN=7.5 to 25V
REG2Load regulation	Reg.L2	-	-	30	mV	IREG2=0 to 100mA
[5V Switch Block]						
EXTVCC Input Threshold Voltage	Vcc_UVLO	4.2	4.4	4.6	V	EXTVCC: Sweep up
EXTVCC Input Delay Time	TVcc	2	4	8	ms	
Switch Resistance	RVcc	-	1.0	2.0	Ω	
[Under voltage lock out block for DC/DC]						
INTVCC Threshold Voltage	REG1_UVLO	4.0	4.2	4.4	V	INTVCC: Sweep up
REG2 Threshold Voltage	REG2_UVLO	2.45	2.65	2.85	V	REG2: Sweep up
Hysteresis voltage	dV_UVLO	50	100	200	mV	INTVCC, REG2: Sweep down
[Error amplifier block]						
Feed back voltage 1	VFB1	REF1×2 -25m	REF1×2	REF1×2 +25m	V	
FB1 Bias Current	IFB1	5	25	50	μA	FB1=5V
Output Discharge Resistance 1	RDISOUT1	-	1	3	kΩ	
Feed back voltage 2	VFB2	REF2×2 -25m	REF2×2	REF2×2 +25m	V	
FB2 Bias Current	IFB2	3	16	32	μA	FB2=3.3V
Output Discharge Resistance 2	RDISOUT2	-	1	3	kΩ	
REF1, REF2 Bias Current	IREF1, IREF2	-1	-	1	μA	
[H²REG block]						
ON Time 1	TON1	0.860	0.960	1.060	μs	REF=2.5V
ON Time 2	TON2	0.570	0.670	0.770	μs	REF=1.65V
Maximum On Time	TONMAX	3.5	7	14	μs	
Minimum Off Time	TOFFMIN	-	0.2	0.4	μs	
[FET Driver block]						
HG higher side ON resistor	HGHON	-	3.0	6.0	Ω	
HG lower side ON resistor	HGLON	-	2.0	4.0	Ω	
LG higher side ON resistor	LGHON	-	2.0	4.0	Ω	
LG lower side ON resistor	LGLON	-	0.5	1.0	Ω	
[Short circuit protection block]						
SCP Threshold Voltage	VSCP	REF×2×0.66	REF×2×0.7	REF×2×0.74	V	
Delay Time	TSCP	0.5	1	2	ms	
[Current limit protection block]						
Maximum offset voltage	dVSMAX	43	50	57	mV	
Is+1 bias current	IISP1	-	2.5	10	μA	Is+1=2V
Is+2 bias current	IISP2	-	2.5	10	μA	Is+2=2V
[Soft Start block]						
Soft Start Time	TSS	0.5	1.0	2.0	ms	
[SLLM mode control block]						
MCTL terminal voltage 1	VCONT	-0.3	-	0.3	V	Continuous mode
MCTL terminal voltage 2	VQLLM	1.5	-	3.0	V	QL ² M mode (Maximum LG off time : 40usec)
MCTL terminal voltage 3	VSLLM	4.5	-	INTVCC+0.3	V	SL ² M mode (Maximum LG off time : ∞)
MCTL float level	VMCTL	1.5	-	3.0	V	

○Physical Dimensions

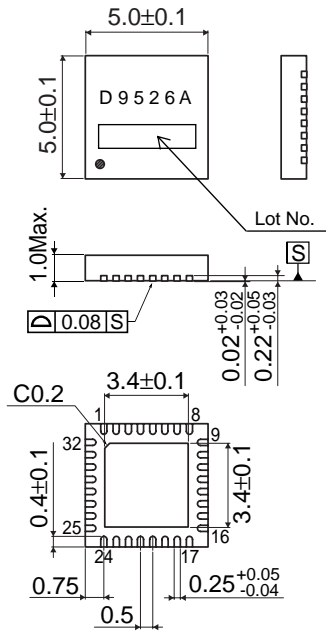

VQFN032-V5050
(UNIT : mm)

○Block Diagram, Application Circuit

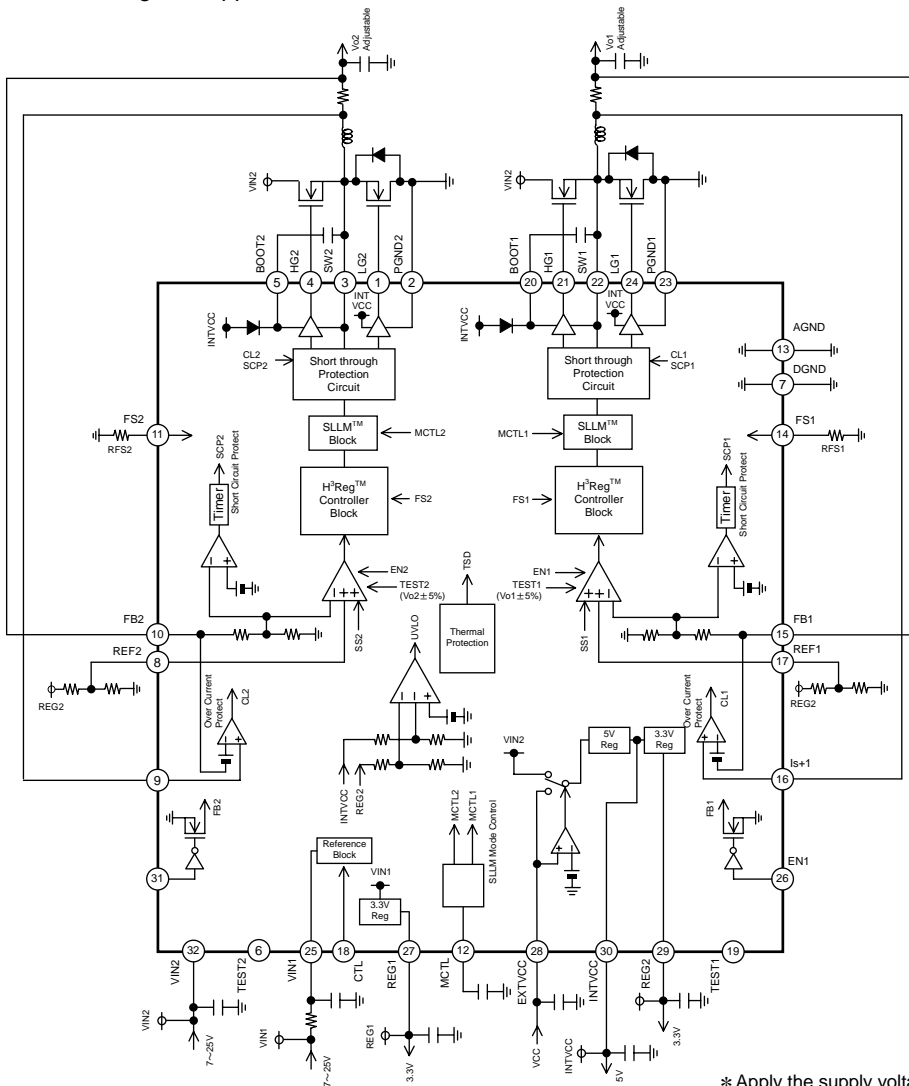

○Pin Description

PIN No.	PIN Name
1	LG2
2	PGND2
3	SW2
4	HG2
5	BOOT2
6	TEST2
7	DGND
8	REF2
9	Is+2
10	FB2
11	FS2
12	MCTL
13	AGND
14	FS1
15	FB1
16	Is+1
17	REF1
18	CTL
19	TEST1
20	BOOT1
21	HG1
22	SW1
23	PGND1
24	LG1
25	VIN1
26	EN1
27	REG1
28	EXTVCC
29	REG2
30	INTVCC
31	EN2
32	VIN2
-	FIN

* Apply the supply voltage EXTVCC pin after INTVCC pin is operated.

○Output condition table

Input			Output				
CTL	EN1	EN2	REG1(3.3V)	REG2(3.3V)	INTVCC	DC/DC1	DC/DC2
Low	Low	Low	OFF	OFF	OFF	OFF	OFF
Low	Low	High	OFF	OFF	OFF	OFF	OFF
Low	High	Low	OFF	OFF	OFF	OFF	OFF
Low	High	High	OFF	OFF	OFF	OFF	OFF
High	Low	Low	ON	ON	ON	OFF	OFF
High	Low	High	ON	ON	ON	OFF	ON
High	High	Low	ON	ON	ON	ON	OFF
High	High	High	ON	ON	ON	ON	ON

○NOTE FOR USE

(1) Absolute maximum rating

The device may be destroyed when applied voltage or operating temperature exceeds its absolute maximum rating. Because the source, such as short mode or open mode, cannot be identified if the device is destroyed, it is important to take physical safety measures (such as fusing) if a special mode in excess of absolute rating limits is to be implemented.

(2) Supply line

In case the motor's reverse electromotive force gives rise to the return of regenerative current, measures should be taken to establish a channel for the current, such as adding a capacitor between the power supply and GND. In determining the approach to take, make sure that no problems will be posed by the various characteristics involved, such as capacitance loss at low temperatures with an electrolytic capacitor.

(3) GND potential

Make sure the potential for the GND pin is always kept lower than the potentials of all other pins, regardless of the operating mode.

(4) Thermal design

Be sure to factor in allowable power dissipation (Pd) in actual operation, and to build sufficient margin into the thermal design to accommodate this power loss.

(5) Operation in strong magnetic fields

Use in strong electromagnetic fields may cause malfunctions. Exercise caution with respect to electromagnetic fields.

(6) ASO

Set the parameters so that output Tr will not exceed the absolute maximum rating or ASO value when the IC is used.

(7) Thermal shutdown circuit

This IC is provided with a built-in thermal shutdown (TSD) circuit, which is activated when the chip temperature reaches the threshold value listed below. When TSD is on, the device goes to high impedance mode. Note that the TSD circuit is provided for the exclusive purpose shutting down the IC in the presence of extreme heat, and is not designed to protect the IC per se or guarantee performance when or after extreme heat conditions occur. Therefore, do not operate the IC with the expectation of continued use or subsequent operation once the TSD is activated.

TSD ON temperature [°C] (typ.)	Hysteresis temperature [°C] (typ.)
175	15

(8) Ground wiring pattern

When both a small-signal GND and high current GND are present, single-point grounding (at the set standard point) is recommended, in order to separate the small-signal and high current patterns, and to be sure the voltage change stemming from the wiring resistance and high current does not cause any voltage change in the small-signal GND. In the same way, care must be taken to avoid wiring pattern fluctuations in any connected external component GND.

(9) Heat sink (FIN)

Since the heat sink (FIN) is connected with the Sub, short it to the GND.

(10) For ICs with more than one power supply, it is possible that rush current may flow instantaneously due to the internal powering sequence and delays. Therefore, give special consideration to power coupling capacitance, power wiring, width of GND wiring, and routing of wiring.

(11) Short-circuits between pins and and mounting errors

Do not short-circuit between output pin and supply pin or ground, or between supply pin and ground. Mounting errors, such as incorrect positioning or orientation, may destroy the device.

Notes

No copying or reproduction of this document, in part or in whole, is permitted without the consent of ROHM CO.,LTD.

The content specified herein is subject to change for improvement without notice.

The content specified herein is for the purpose of introducing ROHM's products (hereinafter "Products"). If you wish to use any such Product, please be sure to refer to the specifications, which can be obtained from ROHM upon request.

Examples of application circuits, circuit constants and any other information contained herein illustrate the standard usage and operations of the Products. The peripheral conditions must be taken into account when designing circuits for mass production.

Great care was taken in ensuring the accuracy of the information specified in this document. However, should you incur any damage arising from any inaccuracy or misprint of such information, ROHM shall bear no responsibility for such damage.

The technical information specified herein is intended only to show the typical functions of and examples of application circuits for the Products. ROHM does not grant you, explicitly or implicitly, any license to use or exercise intellectual property or other rights held by ROHM and other parties. ROHM shall bear no responsibility whatsoever for any dispute arising from the use of such technical information.

The Products specified in this document are intended to be used with general-use electronic equipment or devices (such as audio visual equipment, office-automation equipment, communication devices, electronic appliances and amusement devices).

The Products are not designed to be radiation tolerant.

While ROHM always makes efforts to enhance the quality and reliability of its Products, a Product may fail or malfunction for a variety of reasons.

Please be sure to implement in your equipment using the Products safety measures to guard against the possibility of physical injury, fire or any other damage caused in the event of the failure of any Product, such as derating, redundancy, fire control and fail-safe designs. ROHM shall bear no responsibility whatsoever for your use of any Product outside of the prescribed scope or not in accordance with the instruction manual.

The Products are not designed or manufactured to be used with any equipment, device or system which requires an extremely high level of reliability the failure or malfunction of which may result in a direct threat to human life or create a risk of human injury (such as a medical instrument, transportation equipment, aerospace machinery, nuclear-reactor controller, fuel-controller or other safety device). ROHM shall bear no responsibility in any way for use of any of the Products for the above special purposes. If a Product is intended to be used for any such special purpose, please contact a ROHM sales representative before purchasing.

If you intend to export or ship overseas any Product or technology specified herein that may be controlled under the Foreign Exchange and the Foreign Trade Law, you will be required to obtain a license or permit under the Law.

Thank you for your accessing to ROHM product informations.

More detail product informations and catalogs are available, please contact your nearest sales office.

ROHM Customer Support System

THE AMERICAS / EUROPE / ASIA / JAPAN

www.rohm.com

Contact us : webmaster@rohm.co.jp