



DACO SEMICONDUCTOR CO., LTD. MBR60030CT(R)L

LOW VF SCHOTTKY DIODE MODULE TYPE 600A

Features

High Surge Capability

600Amp Rectifier
30 Volts

Maximum Ratings

Operating Temperature: -40 °C to +100 °C

Storage Temperature: -40 °C to +150 °C

Part Number	Maximum Recurrent Peak Reverse Voltage	Maximum RMS Voltage	Maximum DC Blocking Voltage
MBR60030CT(R)L	30V	21V	30V

TWIN TOWER

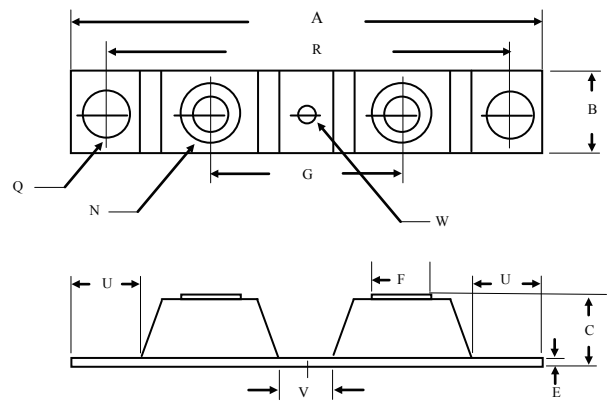

Electrical Characteristics @ 25 °C Unless Otherwise Specified

Average Forward Current (Per pkg)	$I_{F(AV)}$	600A	$T_C=100^{\circ}C$
Peak Forward Surge Current (Per leg)	I_{FSM}	4000A	8.3ms, half sine
Maximum Instantaneous Forward Voltage (Per leg)	V_F	0.58V	$I_{FM}=300A; T_J=25^{\circ}C$
Maximum Instantaneous Reverse Current At Rated DC Blocking Voltage (Per leg)	I_R	3mA 250mA	$T_J=25^{\circ}C$ $T_J=100^{\circ}C$
Maximum Thermal Resistance Junction To Case (Per leg)	$R_{\theta jc}$	0.28 °C/W	

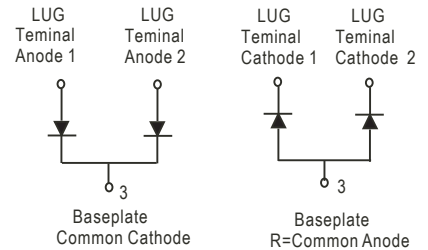

DIM	Inches		Millimeters	
	Min	Max	Min	Max
A	----	3.630	----	92.40
B	0.700	0.800	17.78	20.32
C	----	0.650	----	16.51
E	0.130	0.141	3.30	3.60
F	0.482	0.490	12.25	12.45
G	1.368	BSC	34.75	BSC
N	1/4-20 UNC FULL			
Q	0.275	0.290	6.99	7.37
R	3.150	BSC	80.01	BSC
U	0.600	----	15.24	----
V	0.312	0.370	7.92	9.40
W	0.180	0.195	4.57	4.95

NOTE :

(1) Pulse Test: Pulse Width 300 μ sec. Duty Cycle < 2%



Figure .1-Typical Forward Characteristics

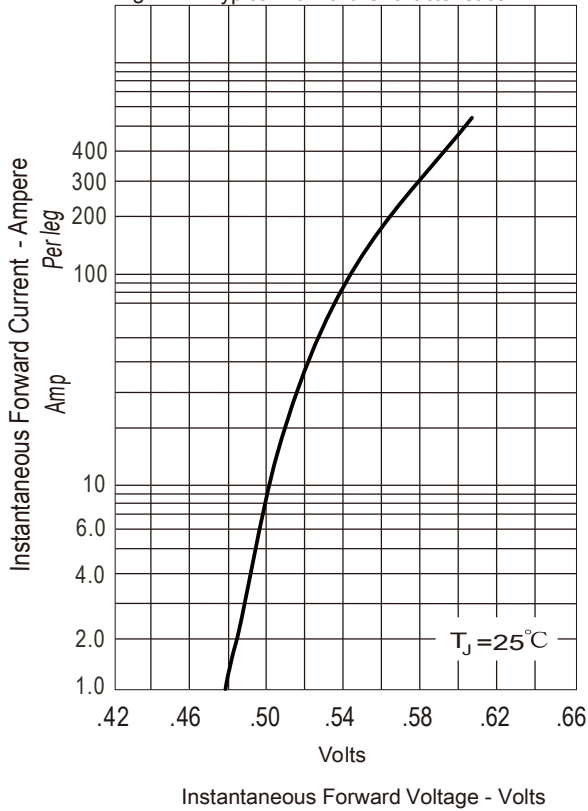

Figure .2- Forward Derating Curve

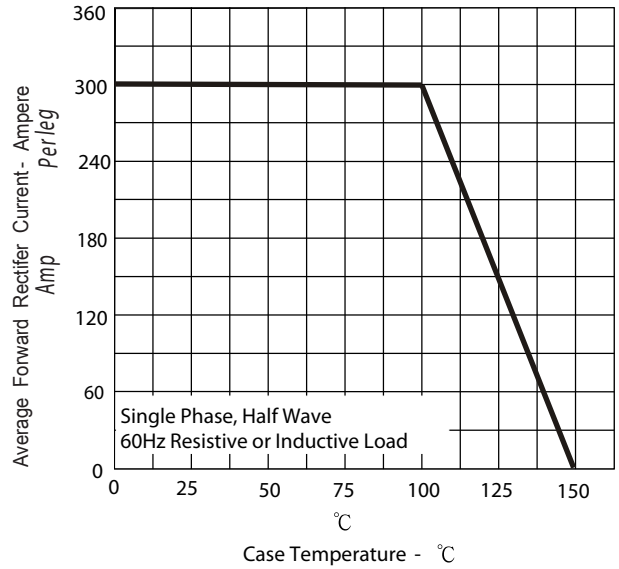

Figure .4- Typical Reverse Characteristics

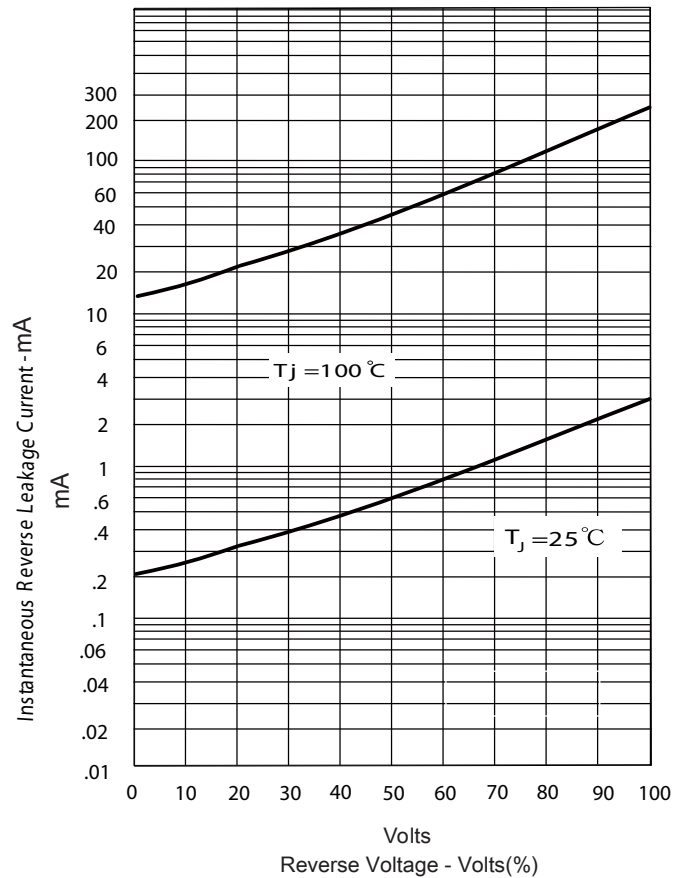

Figure .3- Peak Forward Surge Current

