

## Rochester Electronics Manufactured Components

Rochester branded components are manufactured using either die/wafers purchased from the original suppliers or Rochester wafers recreated from the original IP. All recreations are done with the approval of the OCM.

Parts are tested using original factory test programs or Rochester developed test solutions to guarantee product meets or exceed the OCM data sheet.

## Quality Overview

- ISO-9001
- AS9120 certification
- Qualified Manufacturers List (QML) MIL-PRF-35835
  - Class Q Military
  - Class V Space Level
- Qualified Suppliers List of Distributors (QSLD)
  - Rochester is a critical supplier to DLA and meets all industry and DLA standards.

Rochester Electronics, LLC is committed to supplying products that satisfy customer expectations for quality and are equal to those originally supplied by industry manufacturers.

The original manufacturer's datasheet accompanying this document reflects the performance and specifications of the Rochester manufactured version of this device. Rochester Electronics guarantees the performance of its semiconductor products to the original OEM specifications. 'Typical' values are for reference purposes only. Certain minimum or maximum ratings may be based on product characterization, design, simulation, or sample testing.

## 54174/DM54174/DM74174, 54175/DM54175/DM74175 Hex/Quad D Flip-Flops with Clear

### General Description

These positive-edge triggered flip-flops utilize TTL circuitry to implement D-type flip-flop logic. All have a direct clear input, and the quad (175) version features complementary outputs from each flip-flop.

Information at the D inputs meeting the setup and hold time requirements is transferred to the Q outputs on the positive-going edge of the clock pulse. Clock triggering occurs at a particular voltage level and is not directly related to the transition time of the positive-going pulse. When the clock input is at either the high or low level, the D input signal has no effect at the output.

### Features

- 174 contains six flip-flops with single-rail outputs
- 175 contains four flip-flops with double-rail outputs
- Buffered clock and direct clear inputs
- Individual data input to each flip-flop
- Applications include:
  - Buffer/storage registers
  - Shift registers
  - Pattern generators
- Typical clock frequency 40 MHz
- Typical power dissipation per flip-flop 38 mW
- Alternate Military/Aerospace device (54174, 54175) is available. Contact a National Semiconductor Sales Office/Distributor for specifications.

### Connection Diagrams

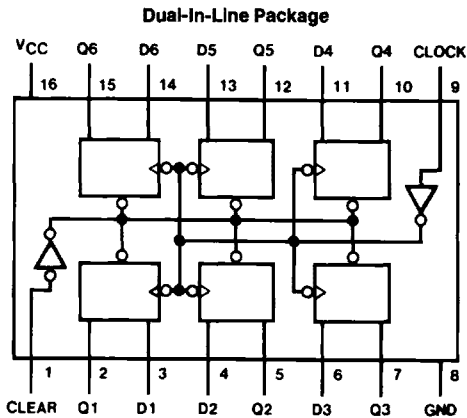

Order Number 54174DMQB, 54174FMB, DM54174J,  
DM54174W or DM74174N  
See NS Package Number J16A, N16E or W16A

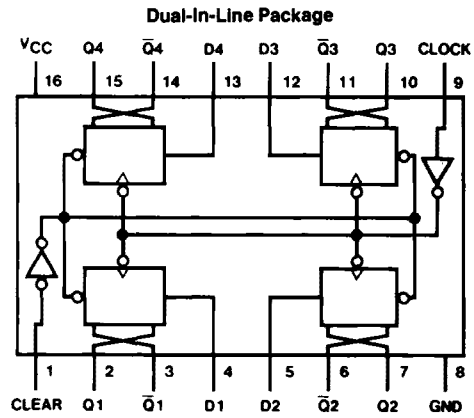

Order Number 54175DMQB, 54175FMB, DM54175J,  
DM54175W or DM74175N  
See NS Package Number J16A, N16E or W16A

### Function Table (Each Flip-Flop)

Inputs			Outputs	
Clear	Clock	D	Q	Q <sup>+</sup>
L	X	X	L	H
H	↑	H	H	L
H	↑	L	L	H
H	L	X	Q <sub>0</sub>	Q <sub>0</sub> <sup>+</sup>

H = High Level (steady state)

L = Low Level (steady state)

X = Don't Care

↑ = Transition from low to high level

Q<sub>0</sub> = The level of Q before the indicated steady-state input conditions were established.

<sup>+</sup> = 175 only

## Absolute Maximum Ratings (Note)

If Military/Aerospace specified devices are required, please contact the National Semiconductor Sales Office/Distributors for availability and specifications.

Supply Voltage	7V
Input Voltage	5.5V
Operating Free Air Temperature Range	
DM54 and 54	-55°C to +125°C
DM74	0°C to +70°C
Storage Temperature Range	-65°C to +150°C

Note: The "Absolute Maximum Ratings" are those values beyond which the safety of the device cannot be guaranteed. The device should not be operated at these limits. The parametric values defined in the "Electrical Characteristics" table are not guaranteed at the absolute maximum ratings. The "Recommended Operating Conditions" table will define the conditions for actual device operation.

## Recommended Operating Conditions

Symbol	Parameter	DM54174			DM74174			Units
		Min	Nom	Max	Min	Nom	Max	
V <sub>CC</sub>	Supply Voltage	4.5	5	5.5	4.75	5	5.25	V
V <sub>IH</sub>	High Level Input Voltage	2			2			V
V <sub>IL</sub>	Low Level Input Voltage			0.8			0.8	V
I <sub>OH</sub>	High Level Output Current			-0.8			-0.8	mA
I <sub>OL</sub>	Low Level Output Current			16			16	mA
f <sub>CLK</sub>	Clock Frequency (Note 4)	0		30	0		30	MHz
t <sub>w</sub>	Pulse Width (Note 4)	Clock Low	25		25			ns
		Clock High	10		10			
		Clear	20		20			
t <sub>SU</sub>	Data Setup Time (Note 4)	20			20			ns
t <sub>H</sub>	Data Hold Time (Note 4)	0			0			ns
t <sub>REL</sub>	Clear Release Time (Note 4)	30			30			ns
T <sub>A</sub>	Free Air Operating Temperature	-55		125	0		70	°C

## '174 Electrical Characteristics

over recommended operating free air temperature range (unless otherwise noted)

Symbol	Parameter	Conditions	Min	Typ (Note 1)	Max	Units
V <sub>I</sub>	Input Clamp Voltage	V <sub>CC</sub> = Min, I <sub>I</sub> = -12 mA			-1.5	V
V <sub>OH</sub>	High Level Output Voltage	V <sub>CC</sub> = Min, I <sub>OH</sub> = Max V <sub>IL</sub> = Max, V <sub>IH</sub> = Min	2.4			V
V <sub>OL</sub>	Low Level Output Voltage	V <sub>CC</sub> = Min, I <sub>OL</sub> = Max V <sub>IH</sub> = Min, V <sub>IL</sub> = Max			0.4	V
I <sub>I</sub>	Input Current @ Max Input Voltage	V <sub>CC</sub> = Max, V <sub>I</sub> = 5.5V			1	mA
I <sub>IH</sub>	High Level Input Current	V <sub>CC</sub> = Max, V <sub>I</sub> = 2.4V			40	μA
I <sub>IL</sub>	Low Level Input Current	V <sub>CC</sub> = Max, V <sub>I</sub> = 0.4V			-1.6	mA
I <sub>OS</sub>	Short Circuit Output Current	V <sub>CC</sub> = Max (Note 2)	DM54	-20	-57	mA
			DM74	-18	-57	
I <sub>CC</sub>	Supply Current	V <sub>CC</sub> = Max (Note 3)		45	65	mA

Note 1: All typicals are at V<sub>CC</sub> = 5V, T<sub>A</sub> = 25°C.

Note 2: Not more than one output should be shorted at a time.

Note 3: With all outputs open and all DATA and CLEAR inputs at 4.5V, I<sub>CC</sub> is measured after a momentary ground, then 4.5V applied to the CLOCK input.

Note 4: T<sub>A</sub> = 25°C and V<sub>CC</sub> = 5V.

## '174 Switching Characteristics

at  $V_{CC} = 5V$  and  $T_A = 25^\circ C$  (See Section 1 for Test Waveforms and Output Load)

Symbol	Parameter	From (Input) To (Output)	$R_L = 400\Omega, C_L = 15\text{ pF}$		Units
			Min	Max	
$f_{MAX}$	Maximum Clock Frequency		30		MHz
$t_{PLH}$	Propagation Delay Time Low to High Level Output	Clock to Any Q		25	ns
$t_{PHL}$	Propagation Delay Time High to Low Level Output	Clock to Any Q		25	ns
$t_{PHL}$	Propagation Delay Time High to Low Level Output	Clear to Any Q		40	ns

## Recommended Operating Conditions

Symbol	Parameter	DM54175			DM74175			Units
		Min	Nom	Max	Min	Nom	Max	
$V_{CC}$	Supply Voltage	4.5	5	5.5	4.75	5	5.25	V
$V_{IH}$	High Level Input Voltage	2			2			V
$V_{IL}$	Low Level Input Voltage			0.8			0.8	V
$I_{OH}$	High Level Output Current			-0.8			-0.8	mA
$I_{OL}$	Low Level Output Current			16			16	mA
$f_{CLK}$	Clock Frequency (Note 1)	0		30	0		30	MHz
$t_w$	Pulse Width (Note 1)	Clock Low	25		25			ns
		Clock High	10		10			
		Clear	20		20			
$t_{SU}$	Data Setup Time (Note 1)	20			20			ns
$t_H$	Data Hold Time (Note 1)	0			0			ns
$t_{REL}$	Clear Release Time (Note 1)	30			30			ns
$T_A$	Free Air Operating Temperature	-55		125	0		70	$^\circ C$

Note 1:  $T_A = 25^\circ C$  and  $V_{CC} = 5V$ .

## '175 Electrical Characteristics

over recommended operating free air temperature range (unless otherwise noted)

Symbol	Parameter	Conditions	Min	Typ (Note 1)	Max	Units
$V_I$	Input Clamp Voltage	$V_{CC} = \text{Min}, I_I = -12 \text{ mA}$			-1.5	V
$V_{OH}$	High Level Output Voltage	$V_{CC} = \text{Min}, I_{OH} = \text{Max}$ $V_{IL} = \text{Max}, V_{IH} = \text{Min}$	2.4			V
$V_{OL}$	Low Level Output Voltage	$V_{CC} = \text{Min}, I_{OL} = \text{Max}$ $V_{IH} = \text{Min}, V_{IL} = \text{Max}$			0.4	V
$I_I$	Input Current @ Max Input Voltage	$V_{CC} = \text{Max}, V_I = 5.5 \text{ V}$			1	mA
$I_{IH}$	High Level Input Current	$V_{CC} = \text{Max}, V_I = 2.4 \text{ V}$			40	$\mu\text{A}$
$I_{IL}$	Low Level Input Current	$V_{CC} = \text{Max}, V_I = 0.4 \text{ V}$			-1.6	mA
$I_{OS}$	Short Circuit Output Current	$V_{CC} = \text{Max}$ (Note 2)	DM54	-20	-57	mA
			DM74	-18	-57	
$I_{CC}$	Supply Current	$V_{CC} = \text{Max}$ (Note 3)		30	45	mA

## '175 Switching Characteristics

at  $V_{CC} = 5 \text{ V}$  and  $T_A = 25^\circ\text{C}$  (See Section 1 for Test Waveforms and Output Load)

Symbol	Parameter	From (Input) To (Output)	$R_L = 400\Omega, C_L = 15 \text{ pF}$		Units
			Min	Max	
$f_{MAX}$	Maximum Clock Frequency		30		MHz
$t_{PLH}$	Propagation Delay Time Low to High Level Output	Clock to Any Q or $\bar{Q}$		25	ns
$t_{PHL}$	Propagation Delay Time High to Low Level Output	Clock to Any Q or $\bar{Q}$		25	ns
$t_{PLH}$	Propagation Delay Time Low to High Level Output	Clear to Any $\bar{Q}$		25	ns
$t_{PHL}$	Propagation Delay Time High to Low Level Output	Clear to Any Q		40	ns

**Note 1:** All typicals are at  $V_{CC} = 5 \text{ V}$ ,  $T_A = 25^\circ\text{C}$ .

**Note 2:** Not more than one output should be shorted at a time.

**Note 3:** With all outputs open and 4.5V applied to all DATA and CLEAR inputs,  $I_{CC}$  is measured after a momentary ground then 4.5V applied to the CLOCK.

# Logic Diagrams

174•175

174

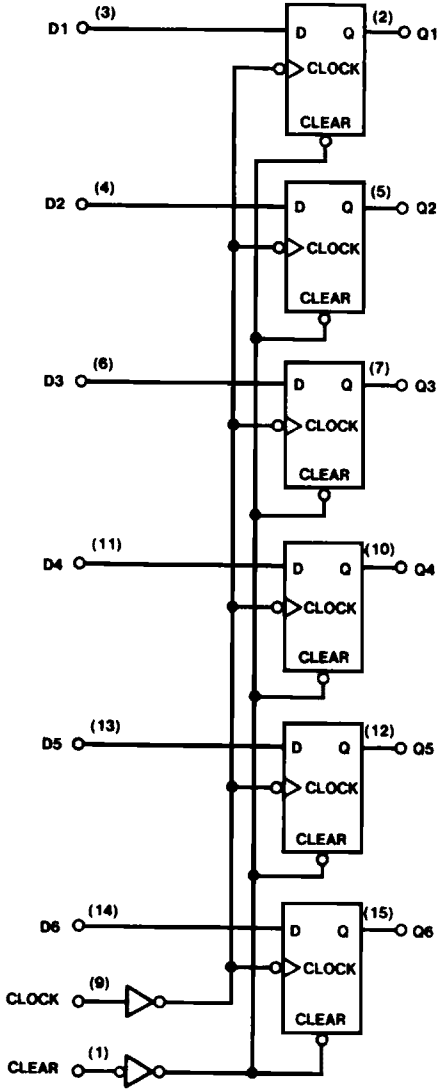

TL/F/6557-3

175

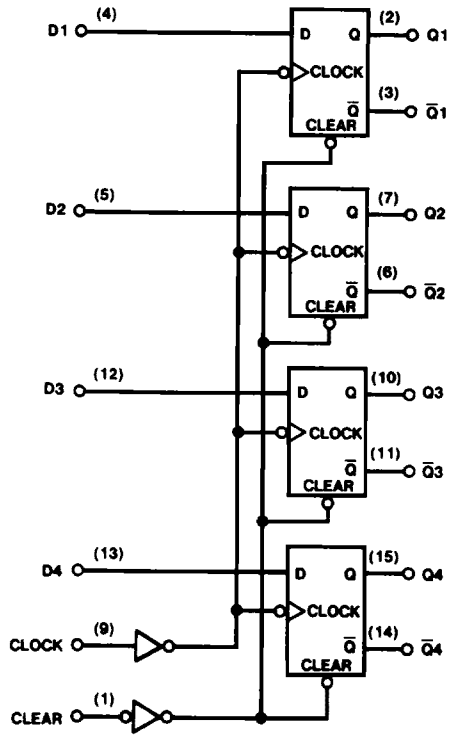

TL/F/6557-4