

**74ACT11245**  
**OCTAL BUS TRANSCEIVER**  
**WITH 3-STATE OUTPUTS**  
 SCAS031C – JULY 1987 – REVISED APRIL 1996

- 3-State Outputs Drive Bus Lines Directly
- Inputs Are TTL-Voltage Compatible
- Flow-Through Architecture Optimizes PCB Layout
- Center-Pin  $V_{CC}$  and GND Configurations Minimize High-Speed Switching Noise
- EPIC™ (Enhanced-Performance Implanted CMOS) 1- $\mu$ m Process
- 500-mA Typical Latch-Up Immunity at 125°C
- Package Options include Plastic Small-Outline (DW), Shrink Small-Outline (DB), and Thin Shrink Small-Outline (PW) Packages, and Standard Plastic 300-mil DIPs (NT)

DB, DW, NT, OR PW PACKAGE  
(TOP VIEW)

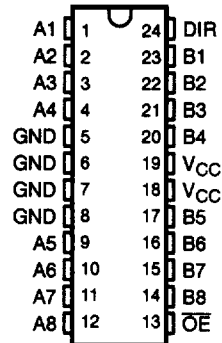

**description**

The octal bus transceiver is designed for asynchronous two-way communication between data buses. The control-function implementation minimizes external timing requirements.

The device allows data transmission from the A bus to the B bus or from the B bus to the A bus, depending on the logic level at the direction-control (DIR) input. The output-enable ( $\overline{OE}$ ) input can be used to disable the device so that the buses are effectively isolated.

The 74ACT11245 is characterized for operation from  $-40^{\circ}\text{C}$  to  $85^{\circ}\text{C}$ .

**FUNCTION TABLE**

OUTPUT ENABLE $\overline{OE}$	DIRECTION CONTROL DIR	OUTPUT
L	L	B data to A bus
L	H	A data to B bus
H	X	isolation

EPIC is a trademark of Texas Instruments Incorporated.

PRODUCTION DATA information is current as of publication date. Products conform to specifications per the terms of Texas Instruments standard warranty. Production processing does not necessarily include testing of all parameters.



POST OFFICE BOX 655303 • DALLAS, TEXAS 75266

Copyright © 1996, Texas Instruments Incorporated

**74ACT11245**  
**OCTAL BUS TRANSCEIVER**  
**WITH 3-STATE OUTPUTS**  
 SCAS031C - JULY 1987 - REVISED APRIL 1996

**logic symbol†**

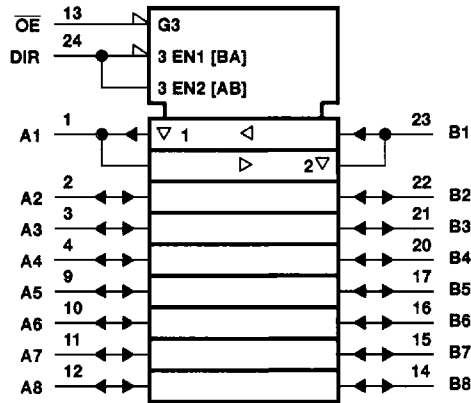

† This symbol is in accordance with ANSI/IEEE Std 91-1984 and IEC Publication 617-12.

**logic diagram (positive logic)**

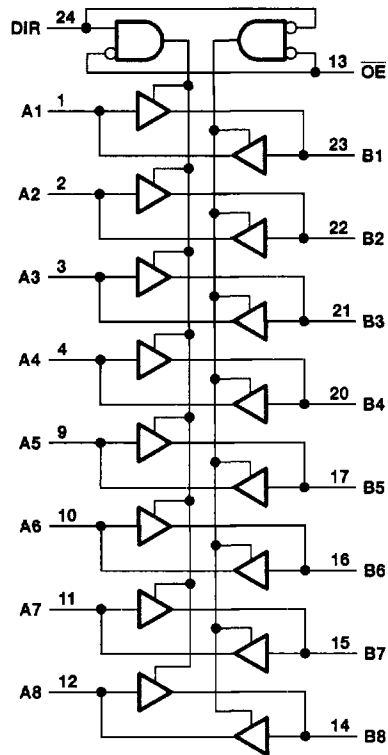

**74ACT11245**  
**OCTAL BUS TRANSCEIVER**  
**WITH 3-STATE OUTPUTS**  
 SCAS031C – JULY 1987 – REVISED APRIL 1996

**absolute maximum ratings over operating free-air temperature range (unless otherwise noted)†**

Supply voltage range, $V_{CC}$ .....	-0.5 V to 7 V
Input voltage range, $V_I$ (see Note 1) .....	-0.5 V to $V_{CC} + 0.5$ V
Output voltage range, $V_O$ (see Note 1) .....	-0.5 V to $V_{CC} + 0.5$ V
Input clamp current, $I_{IK}$ ( $V_I < 0$ or $V_I > V_{CC}$ ) .....	$\pm 20$ mA
Output clamp current, $I_{OK}$ ( $V_O < 0$ or $V_O > V_{CC}$ ) .....	$\pm 50$ mA
Continuous output current, $I_O$ ( $V_O = 0$ to $V_{CC}$ ) .....	$\pm 50$ mA
Continuous current through $V_{CC}$ or GND .....	$\pm 200$ mA
Maximum power dissipation at $T_A = 55^\circ\text{C}$ (in still air) (see Note 2): DB package .....	0.65 W
DW package .....	1.7 W
NT package .....	1.3 W
PW package .....	0.7 W
Storage temperature range, $T_{stg}$ .....	$-65^\circ\text{C}$ to $150^\circ\text{C}$

† Stresses beyond those listed under "absolute maximum ratings" may cause permanent damage to the device. These are stress ratings only, and functional operation of the device at these or any other conditions beyond those indicated under "recommended operating conditions" is not implied. Exposure to absolute-maximum-rated conditions for extended periods may affect device reliability.

- NOTES: 1. The input and output voltage ratings may be exceeded if the input and output current ratings are observed.  
 2. The maximum package power dissipation is calculated using a junction temperature of  $150^\circ\text{C}$  and a board trace length of 750 mils, except for the NT package, which has a trace length of zero.

**recommended operating conditions**

	MIN	MAX	UNIT
$V_{CC}$ Supply voltage	4.5	5.5	V
$V_{IH}$ High-level input voltage	2		V
$V_{IL}$ Low-level input voltage		0.8	V
$V_I$ Input voltage	0	$V_{CC}$	V
$V_O$ Output voltage	0	$V_{CC}$	V
$I_{OH}$ High-level output current		-24	mA
$I_{OL}$ Low-level output current		24	mA
$\Delta t/\Delta v$ Input transition rise or fall rate	0	10	ns/V
$T_A$ Operating free-air temperature	-40	85	$^\circ\text{C}$



**74ACT11245**  
**OCTAL BUS TRANSCEIVER**  
**WITH 3-STATE OUTPUTS**  
 SCAS031C - JULY 1987 - REVISED APRIL 1996

**electrical characteristics over recommended operating free-air temperature range (unless otherwise noted)**

PARAMETER		TEST CONDITIONS	V <sub>CC</sub>	T <sub>A</sub> = 25°C			MIN	MAX	UNIT
				MIN	TYP	MAX			
V <sub>OH</sub>	I <sub>OH</sub> = -50 μA		4.5 V	4.4			4.4		V
			5.5 V	5.4			5.4		
	I <sub>OH</sub> = -24 mA		4.5 V	3.94			3.8		
			5.5 V	4.94			4.8		
I <sub>OH</sub> = -75 mA <sup>†</sup>		5.5 V				3.85			
V <sub>OL</sub>	I <sub>OL</sub> = 50 μA		4.5 V				0.1		V
			5.5 V				0.1		
	I <sub>OL</sub> = 24 mA		4.5 V				0.36		
			5.5 V				0.36		
I <sub>OL</sub> = 75 mA <sup>†</sup>		5.5 V				1.65			
I <sub>OZ</sub>	A or B ports <sup>‡</sup>	V <sub>O</sub> = V <sub>CC</sub> or GND	5.5 V				±0.5		μA
I <sub>I</sub>	$\overline{OE}$ or DIR	V <sub>I</sub> = V <sub>CC</sub> or GND	5.5 V				±0.1		μA
I <sub>CC</sub>		V <sub>I</sub> = V <sub>CC</sub> or GND, I <sub>O</sub> = 0	5.5 V				8		80 μA
ΔI <sub>CC</sub> <sup>§</sup>		One input at 3.4 V, Other inputs at GND or V <sub>CC</sub>	5.5 V				0.9		1 mA
C <sub>i</sub>		V <sub>I</sub> = V <sub>CC</sub> or GND	5 V	4					pF
C <sub>o</sub>		V <sub>O</sub> = V <sub>CC</sub> or GND	5 V	12					pF

<sup>†</sup> Not more than one output should be tested at a time, and the duration of the test should not exceed 10 ms.

<sup>‡</sup> For I/O ports, the parameter I<sub>OZ</sub> includes the input leakage current.

<sup>§</sup> This is the increase in supply current for each input that is at one of the specified TTL voltage levels rather than 0 V or V<sub>CC</sub>.

**switching characteristics over recommended ranges of supply voltage and operating free-air temperature (unless otherwise noted) (see Figure 1)**

PARAMETER	FROM (INPUT)	TO (OUTPUT)	T <sub>A</sub> = 25°C			MIN	MAX	UNIT
			MIN	TYP	MAX			
t <sub>PLH</sub>	A or B	B or A	1.5	6.2	9.2	1.5	10	ns
t <sub>PHL</sub>			1.5	5.4	8.6	1.5	9.1	
t <sub>PZH</sub>	$\overline{OE}$	A or B	1.5	8.1	12	1.5	13.2	ns
t <sub>PZL</sub>			1.5	8.2	11.7	1.5	12.9	
t <sub>PHZ</sub>	$\overline{OE}$	A or B	1.5	9.3	11.8	1.5	12.9	ns
t <sub>PLZ</sub>			1.5	9.8	12.9	1.5	13.9	

**operating characteristics, V<sub>CC</sub> = 5 V, T<sub>A</sub> = 25°C**

PARAMETER		TEST CONDITIONS		TYP	UNIT
C <sub>pd</sub>	Power dissipation capacitance per transceiver	Outputs enabled	C <sub>L</sub> = 50 pF, f = 1 MHz	66	pF
		Outputs disabled		19	



**PARAMETER MEASUREMENT INFORMATION**

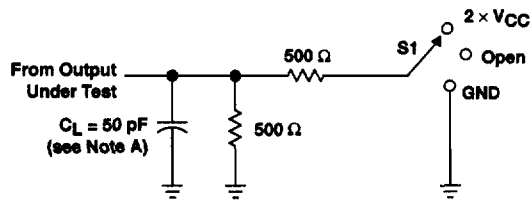

**LOAD CIRCUIT**

TEST	S1
$t_{PLH}/t_{PHL}$	Open
$t_{PLZ}/t_{PZL}$	2 $\times V_{CC}$
$t_{PHZ}/t_{PZH}$	GND

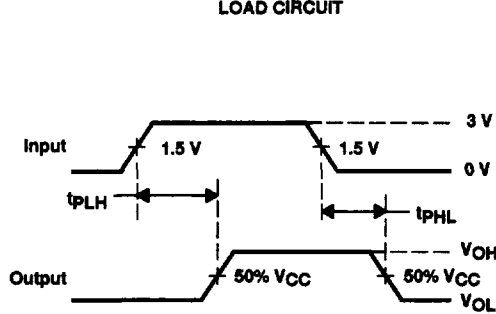

**VOLTAGE WAVEFORMS**

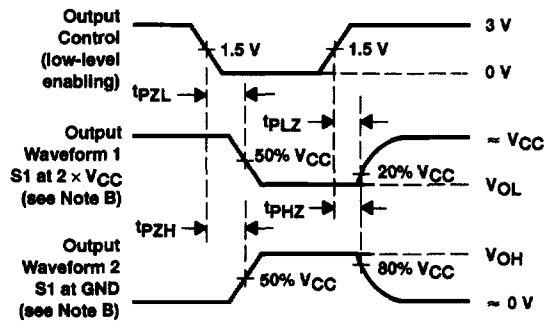

**VOLTAGE WAVEFORMS**

- NOTES: A.  $C_L$  includes probe and jig capacitance.  
 B. Waveform 1 is for an output with internal conditions such that the output is low except when disabled by the output control. Waveform 2 is for an output with internal conditions such that the output is high except when disabled by the output control.  
 C. All input pulses are supplied by generators having the following characteristics: PRR  $\leq 1 \text{ MHz}$ ,  $Z_O = 50 \Omega$ ,  $t_r = 3 \text{ ns}$ ,  $t_f = 3 \text{ ns}$ .  
 D. The outputs are measured one at a time with one input transition per measurement.

**Figure 1. Load Circuit and Voltage Waveforms**