

# SN75ALS181 DIFFERENTIAL DRIVER AND RECEIVER PAIR

SLLS152 – D4060, DECEMBER 1992

- Meets EIA Standards RS-422-A, RS-485, and CCITT Recommendations V.11 and X.27
- Low Supply Current Requirements  
30 mA Max
- Driver Output Capacity . . .  $\pm 60$  mA
- Thermal Shutdown Protection
- Driver Common-Mode Output Voltage Range of  $-7$  V to  $12$  V
- Receiver Input Impedance . . .  $12$  k $\Omega$  Min
- Receiver Input Sensitivity . . .  $\pm 200$  mV
- Receiver Input Hysteresis . . .  $60$  mV Typ
- Receiver Common-Mode Input Voltage Range of  $\pm 12$  V
- Operates From Single 5-V Supply
- Glitch-Free Power-Up and Power-Down Protection

## description

The SN75ALS181 differential driver and receiver pair are monolithic integrated circuits designed for bidirectional data communication on multipoint bus transmission lines. The design provides for balanced transmission lines and meets EIA Standards RS-422-A and RS-485, and CCITT recommendations V.10, V.11, X.26, and X.27.

The SN75ALS181 combines a 3-state differential line driver and a differential input line receiver that operate from a single 5-V power supply. The driver and receiver have active-high and active-low enables, respectively, which can be externally connected together to function as a direction control. The driver differential outputs and the receiver differential inputs are connected to separate pins for greater flexibility and are designed to offer minimum loading to the bus when the driver is disabled or  $V_{CC} = 0$ . These ports feature wide positive and negative common-mode voltage changes making the device suitable for party-line applications.

The SN75ALS181 is characterized for operation from  $0^{\circ}\text{C}$  to  $70^{\circ}\text{C}$ .

N OR NS† PACKAGE  
(TOP VIEW)

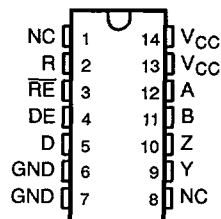

NC – No internal connection

† The NS package is only available in left-end taped and reeled (order device SN75ALS181NSLE).

## Function Tables

EACH DRIVER

INPUT D	ENABLE DE	OUTPUTS	
		Y	Z
H	H	H	L
L	H	L	H
X	L	Z	Z

EACH RECEIVER

DIFFERENTIAL INPUTS A – B	ENABLE RE	OUTPUT R
$V_{ID} \geq 0.2$ V	L	H
$-0.2$ V $< V_{ID} < 0.2$ V	L	?
$V_{ID} \leq -0.2$ V	L	L
X	H	Z

H = high level, L = low level, ? = indeterminate,  
X = irrelevant, Z = high impedance (off)

## logic symbol†

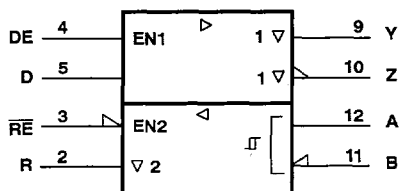

† This symbol is in accordance with ANSI/IEEE Std 91-1984 and IEC Publication 617-12.

## logic diagram (positive logic)

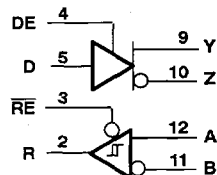

# SN75ALS181 DIFFERENTIAL DRIVER AND RECEIVER PAIR

SLLS152 - D4060, DECEMBER 1992

## schematics of inputs

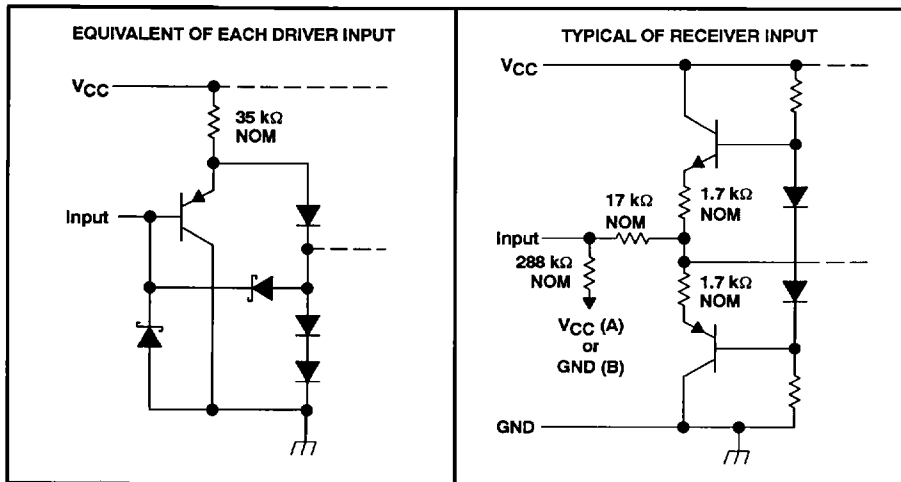

## schematics of outputs

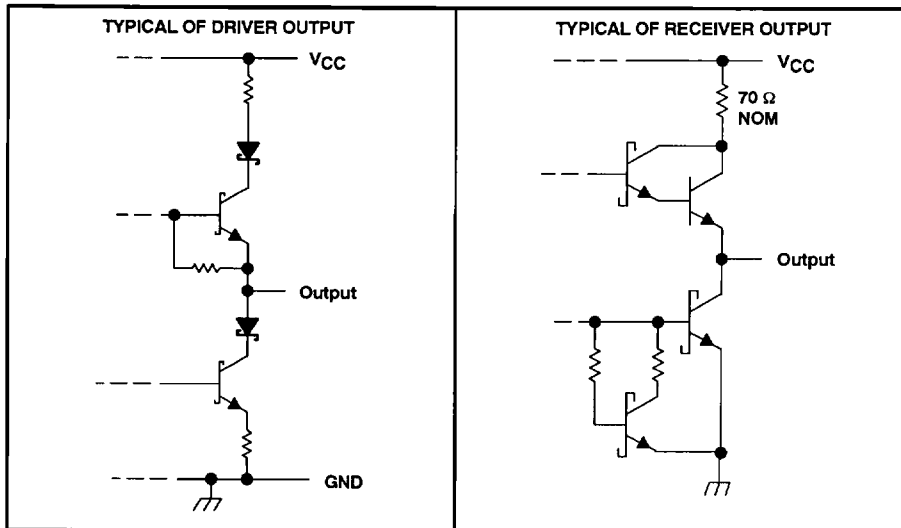

# SN75ALS181 DIFFERENTIAL DRIVER AND RECEIVER PAIR

SLLS152 – D4060, DECEMBER 1992

## absolute maximum ratings over operating free-air temperature range (unless otherwise noted)

Supply voltage, $V_{CC}$ (see Note 1)	7 V
Input voltage, DE, $\overline{RE}$ , and D inputs	7 V
Output voltage range, driver	–9 V to 14 V
Input voltage range, receiver	–14 V to 14 V
Receiver differential input voltage range (see Note 2)	–14 V to 14 V
Continuous total power dissipation	See Dissipation Rating Table
Operating free-air temperature range, $T_A$	0°C to 70°C
Storage temperature range	–65°C to 150°C
Lead temperature 1,6 mm (1/16 inch) from case for 10 seconds	260°C

- NOTES: 1. All voltage values, except differential input voltage, are with respect to network ground terminal.  
 2. Differential input voltage is measured at the noninverting terminal with respect to the inverting terminal.

**DISSIPATION RATING TABLE**

PACKAGE	$T_A \leq 25^\circ\text{C}$ POWER RATING	OPERATING FACTOR ABOVE $T_A = 25^\circ\text{C}$	$T_A = 70^\circ\text{C}$ POWER RATING
N	1150 mW	9.2 mW/°C	736 mW
NS	625 mW	4.0 mW/°C	445 mW

## recommended operating conditions

		MIN	NOM	MAX	UNIT
Supply voltage, $V_{CC}$		4.75	5	5.25	V
Common-mode output voltage, $V_{OC}$ (see Note 3)	Driver	–7		12	V
Common-mode input voltage, $V_{IC}$ (see Note 3)	Receiver	–12		12	V
High-level input current, $V_{IH}$	D, DE, and $\overline{RE}$	2			V
Low-level input current, $V_{IL}$	D, DE, and $\overline{RE}$			0.8	V
Differential input voltage, $V_{ID}$				±12	V
High-level output current, $I_{OH}$	Driver			–60	mA
	Receiver			–400	µA
Low-level output current, $I_{OL}$	Driver			60	mA
	Receiver			8	mA
Operating free-air temperature, $T_A$		0		70	°C

NOTE 3: The algebraic convention, where the less positive (more negative) limit is designated as minimum, is used in this table for common-mode output voltage level only.

# SN75ALS181 DIFFERENTIAL DRIVER AND RECEIVER PAIR

SLLS152 – D4060, DECEMBER 1992

## DRIVER SECTION

electrical characteristics over recommended ranges of supply voltage and operating free-air temperature (unless otherwise noted)

PARAMETER		TEST CONDITIONS		MIN	TYP†	MAX	UNIT	
$V_{IK}$	Input clamp voltage	$I_I = -18 \text{ mA}$				-1.5	V	
$V_O$	Output voltage	$I_O = 0$		0		6	V	
$ V_{OD1} $	Differential output voltage	$I_O = 0$		1.5		6	V	
$ V_{OD2} $	Differential output voltage	$V_{CC} = 5 \text{ V},$ $R_L = 100 \Omega$	See Figure 1	$1/2 V_{OD1}$			V	
$ V_{OD2} $	Differential output voltage	$R_L = 54 \Omega$		2				
$ V_{OD3} $	Differential output voltage	$R_L = 54 \Omega$	See Figure 2	1.5	2.3	5	V	
$ V_{OD3} $	Differential output voltage	$V_{test} = -7 \text{ V to } 12 \text{ V},$		1.5		5	V	
$\Delta V_{OD} $	Change in magnitude of differential output voltage (see Note 4)	$R_L = 54 \Omega \text{ or } 100 \Omega,$ See Figure 1				$\pm 0.2$	V	
$V_{OC}$	Common-mode output voltage					3		V
$\Delta V_{OC} $	Change in magnitude of common-mode output voltage (see Note 4)							$\pm 0.2$
$I_{OZ}$	High-impedance-state output current	$V_O = -7 \text{ V to } 12 \text{ V},$ See Note 5				$\pm 100$	$\mu\text{A}$	
$I_{IH}$	High-level input current	$V_{IH} = 2.4 \text{ V}$				20	$\mu\text{A}$	
$I_{IL}$	Low-level input current	$V_{IL} = 0.4 \text{ V}$				-100	$\mu\text{A}$	
$I_{OS}$	Short-circuit output current	$V_O = -7 \text{ V}$				-250	mA	
		$V_O = V_{CC}$				250		
		$V_O = 12 \text{ V}$				250		
		$V_O = 0 \text{ V}$				-150		
$I_{CC}$	Supply current (total package)	No load	Outputs enabled		21	30	mA	
			Outputs disabled		14	21		

NOTES: 4.  $\Delta|V_{OD}|$  and  $\Delta|V_{OC}|$  are the changes in magnitude of  $V_{OD}$  and  $V_{OC}$ , respectively, that occur when the input is changed from a high level to a low level.

5. This applies for both power on and power off. Refer to EIA Standard RS-485 for exact conditions.

switching characteristics over recommended ranges of supply voltage and operating free-air temperature (unless otherwise noted)

PARAMETER		TEST CONDITIONS			MIN	TYP†	MAX	UNIT
$t_{dD}$	Differential output delay time, $t_{dDH}$ or $t_{dDL}$	$R_L = 54 \Omega,$	$C_L = 50 \text{ pF},$	See Figure 3	9	13	20	ns
$t_{sk(p)}$	Pulse skew ( $ t_{dDH} - t_{dDL} $ )				1	8		
$t_t$	Differential output transition time				3	10	16	
$t_{PZH}$	Output enable time to high level	$R_L = 110 \Omega,$	See Figure 4		36	53	ns	
$t_{PZL}$	Output enable time to low level	$R_L = 110 \Omega,$	See Figure 5		39	56	ns	
$t_{PHZ}$	Output disable time from high level	$R_L = 110 \Omega,$	See Figure 4		20	31	ns	
$t_{PLZ}$	Output disable time from low level	$R_L = 110 \Omega,$	See Figure 5		9	20	ns	

† All typical values are at  $V_{CC} = 5 \text{ V}$  and  $T_A = 25^\circ\text{C}$ .

**RECEIVER SECTION**

**electrical characteristics over recommended ranges of supply voltage, common-mode input voltage, and operating free-air temperature (unless otherwise noted)**

PARAMETER		TEST CONDITIONS		MIN	TYP†	MAX	UNIT
$V_{T+}$	Positive-going threshold voltage, differential input	$V_O = 2.7\text{ V}$ ,	$I_O = -0.4\text{ mA}$			0.2	V
$V_{T-}$	Negative-going threshold voltage, differential input	$V_O = 0.5\text{ V}$ ,	$I_O = 8\text{ mA}$ See Note 8	-0.2			V
$V_{hys}$	Input hysteresis ( $V_{T+} - V_{T-}$ )				60		mV
$V_{IK}$	Input clamp voltage, $\overline{RE}$	$I_I = -18\text{ mA}$				-1.5	V
$V_{OH}$	High-level output voltage	$V_{ID} = 200\text{ mV}$ ,	$I_{OH} = -400\text{ }\mu\text{A}$ , See Figure 6	2.7			V
$V_{OL}$	Low-level output voltage	$V_{ID} = -200\text{ mV}$ ,	$I_{OL} = 8\text{ mA}$ , See Figure 6			0.45	V
$I_{OZ}$	High-impedance-state output current	$V_O = 0.4\text{ V to } 2.4\text{ V}$				$\pm 20$	$\mu\text{A}$
$I_I$	Line input current	Other input at 0 V, See Note 5	$V_I = 12\text{ V}$			1	mA
			$V_I = -7\text{ V}$			-0.8	
$I_{IH}$	High-level input current, $\overline{RE}$	$V_{IH} = 2.7\text{ V}$				20	$\mu\text{A}$
$I_{IL}$	Low-level input current, $\overline{RE}$	$V_{IL} = 0.4\text{ V}$				-100	$\mu\text{A}$
$r_i$	Input resistance			12			$\text{k}\Omega$
$I_{OS}$	Short-circuit output current	$V_{ID} = 200\text{ mV}$ ,	$V_O = 0\text{ V}$	-15		-85	mA
$I_{CC}$	Supply current (total package)	No load	Outputs enabled		21	30	mA
			Outputs disabled		14	21	

NOTE 5: This applies for both power on and power off. Refer to EIA Standards RS-485 for exact conditions.

**switching characteristics over recommended ranges of supply voltage and operating free-air temperature,  $C_L = 15\text{ pF}$  (unless otherwise noted) (see Figure 7)**

PARAMETER		TEST CONDITIONS		MIN	TYP†	MAX	UNIT
$t_{PHL}$	Propagation delay time, high-to-low-level output	$V_{ID} = -1.5\text{ V to } 1.5\text{ V}$		10	16	25	ns
$t_{PLH}$	Propagation delay time, low-to-high-level output	$V_{ID} = -1.5\text{ V to } 1.5\text{ V}$		10	16	25	ns
$t_{sk(p)}$	Pulse skew ( $ t_{PLH} - t_{PHL} $ )	$V_{ID} = -1.5\text{ V to } 1.5\text{ V}$			1	8	ns
$t_{PZH}$	Output enable time to high level				7	15	ns
$t_{PZL}$	Output enable time to low level				9	19	ns
$t_{PHZ}$	Output disable time from high level				18	27	ns
$t_{PLZ}$	Output disable time from low level				10	15	ns

† All typical values are at  $V_{CC} = 5\text{ V}$  and  $T_A = 25^\circ\text{C}$ .

# SN75ALS181 DIFFERENTIAL DRIVER AND RECEIVER PAIR

SLLS152 – D4060, DECEMBER 1992

## PARAMETER MEASUREMENT INFORMATION

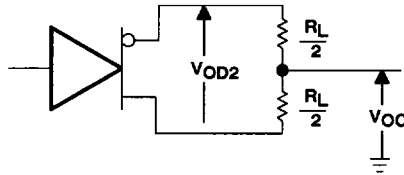

Figure 1. Driver Test Circuit,  $V_{OD}$  and  $V_{OC}$

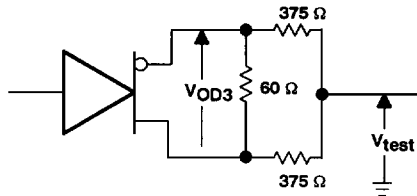
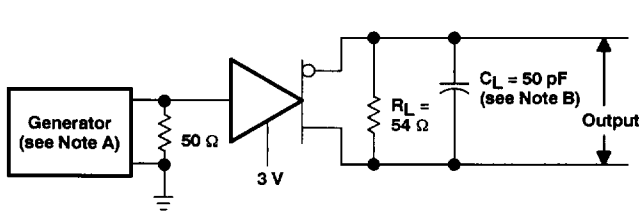
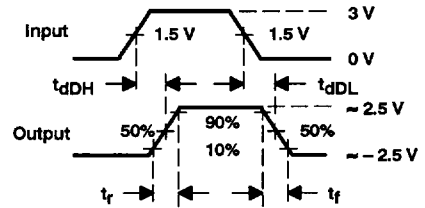

Figure 2. Driver Circuit,  $V_{OD3}$



TEST CIRCUIT



VOLTAGE WAVEFORMS

NOTES: A. The input pulse is supplied by a generator having the following characteristics:  $PRR \leq 1$  MHz, 50% duty cycle,  $t_r \leq 6$  ns,  $t_f \leq 6$  ns,  $Z_0 = 50 \Omega$ .

B.  $C_L$  includes probe and jig capacitance.

Figure 3. Driver Differential-Output Delay and Transition Times

PARAMETER MEASUREMENT INFORMATION

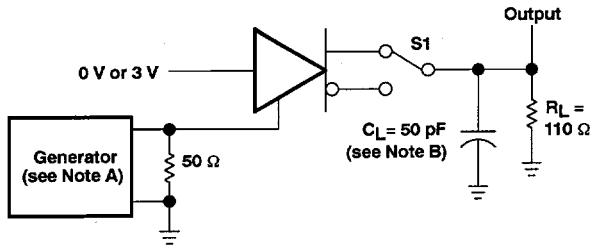

TEST CIRCUIT

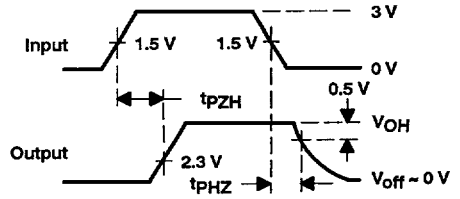

VOLTAGE WAVEFORMS

Figure 4. Driver Enable and Disable Times

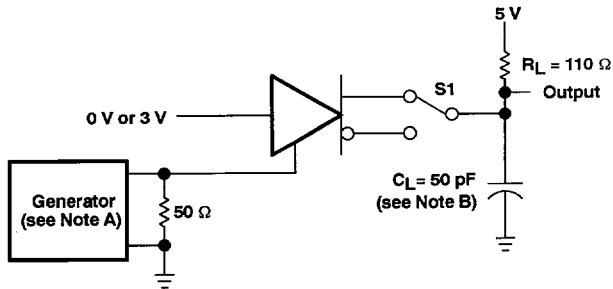

TEST CIRCUIT

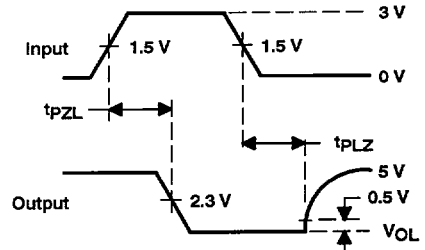

VOLTAGE WAVEFORMS

Figure 5. Driver Enable and Disable Times

NOTES: A. The input pulse is supplied by a generator having the following characteristics: PRR  $\leq$  1 MHz, 50% duty cycle,  $t_r \leq$  6 ns,  $t_f \leq$  3.6 ns,  $Z_O = 50 \Omega$ .  
B.  $C_L$  includes probe and jig capacitance.

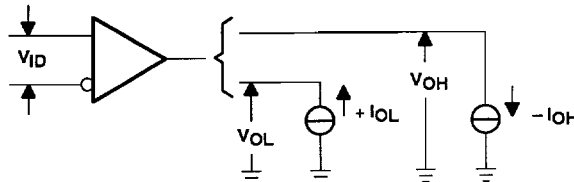

Figure 6. Receiver,  $V_{OH}$  and  $V_{OL}$

# SN75ALS181 DIFFERENTIAL DRIVER AND RECEIVER PAIR

SLLS152 – D4060, DECEMBER 1992

## PARAMETER MEASUREMENT INFORMATION

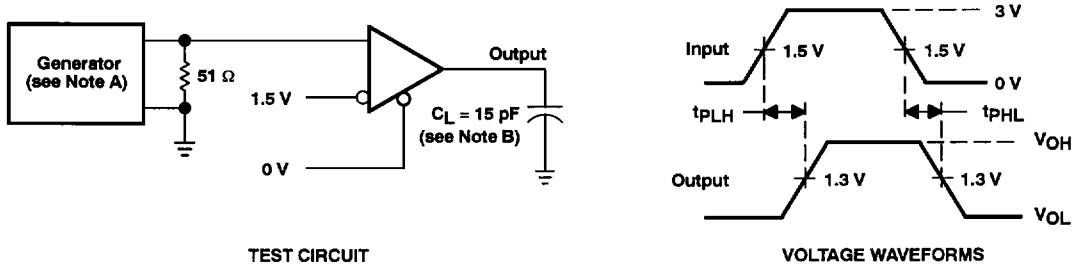

Figure 7. Receiver Propagation Delay Times

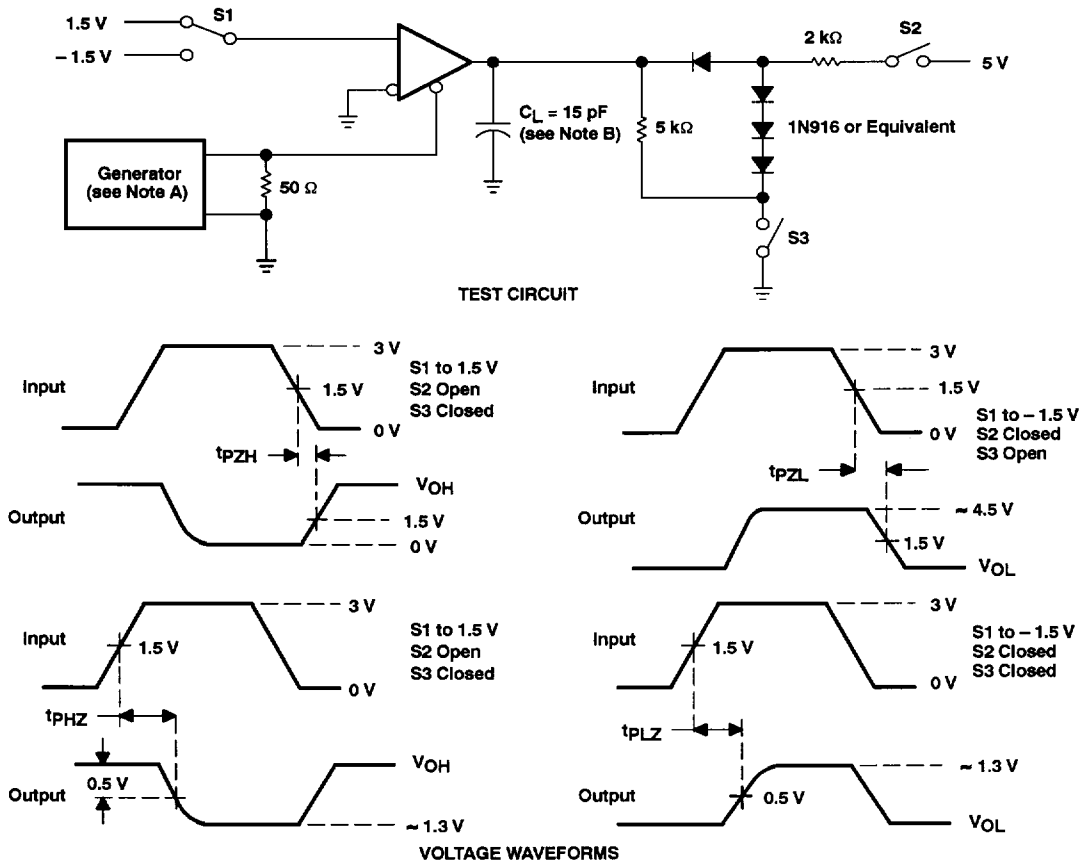

Figure 8. Receiver Output Enable and Disable Times

NOTES: A. The input pulse is supplied by a generator having the following characteristics: PRR  $\leq$  1 MHz, 50% duty cycle,  $t_r \leq$  6 ns,  $t_f \leq$  3.6 ns,  $Z_0 = 50 \Omega$ .

B.  $C_L$  includes probe and jig capacitance.