

# Customer Information Sheet

DRAWING No.: M80-465XXXX

SHEET 2 OF 2

IF IN DOUBT - ASK

©

NOT TO SCALE

THIRD ANGLE PROJECTION

ALL DIMENSIONS IN mm

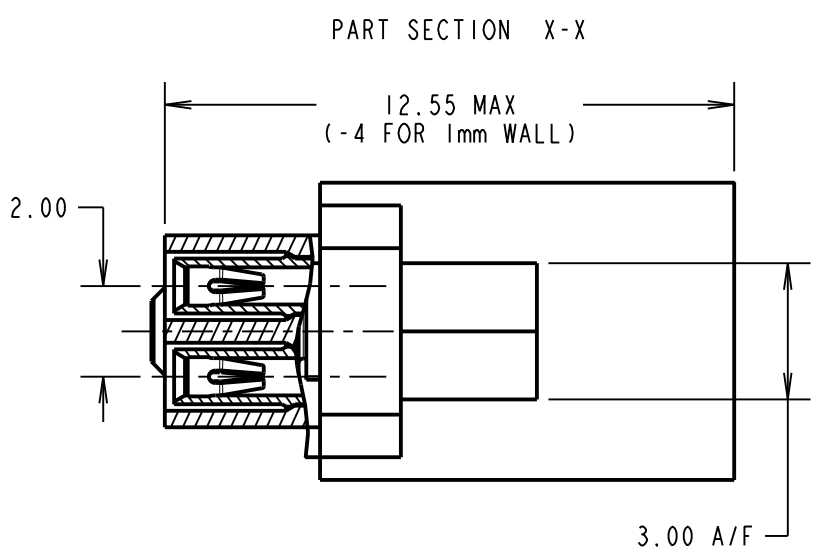
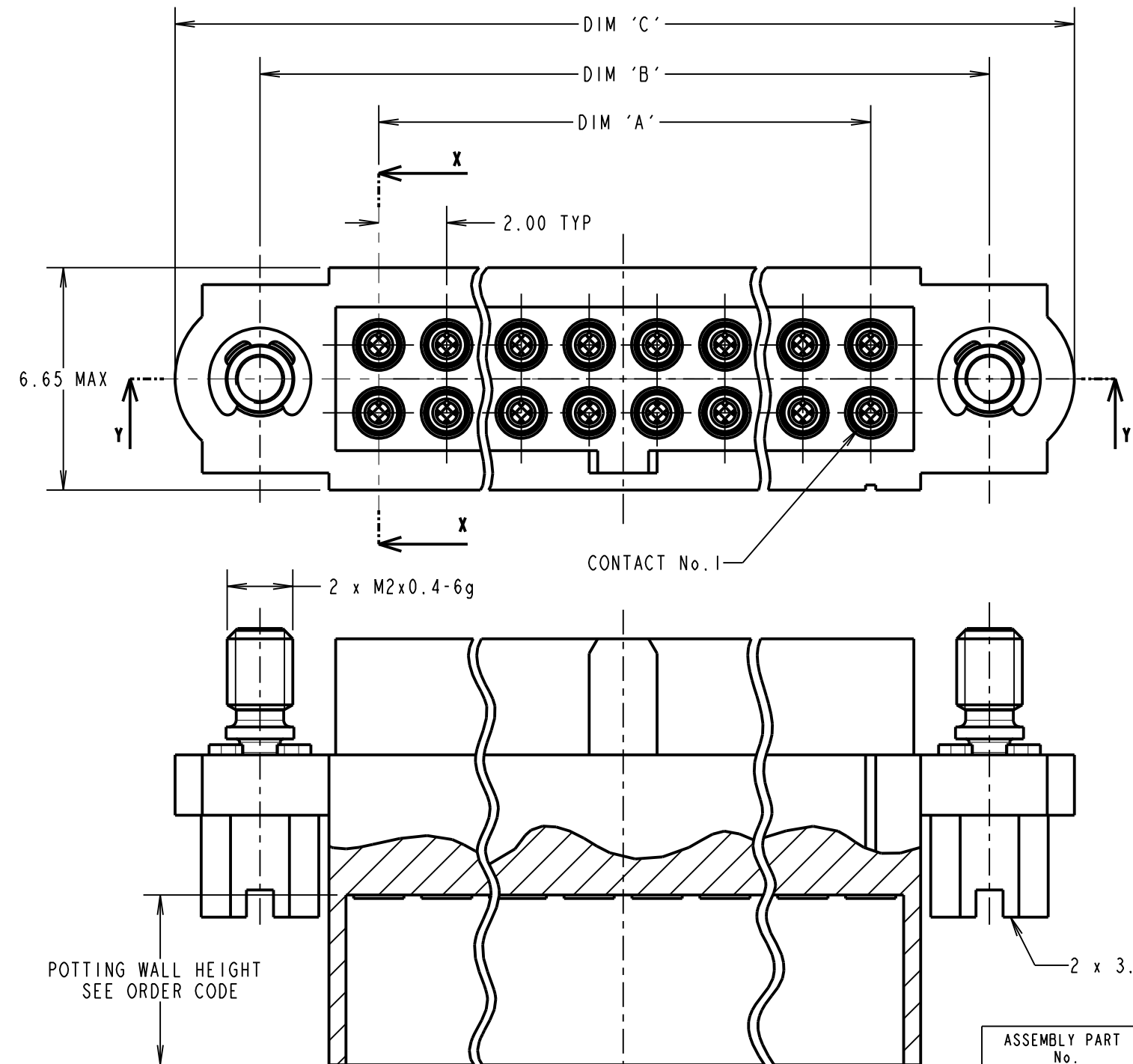

**SPECIFICATIONS:**  
**MATERIAL:**  
 MOULDING = GLASS-FILLED PPS, UL94V-0, BLACK  
 CONTACT CLIP = BERYLLIUM COPPER  
 CONTACT SHELL = BRASS  
 JACKSCREW, CIRCLIP = STAINLESS STEEL  
**FINISH:**  
 05 = 0.3µ GOLD CLIP, 0.25-0.3µ GOLD SHELL  
 42 = 0.3µ GOLD CLIP, 3.5-5.0µ 100% TIN SHELL  
**ELECTRICAL:**  
 CURRENT RATING AT 25°C = 3.0A MAX  
 CURRENT RATING AT 85°C = 2.2A MAX  
 WORKING VOLTAGE = 120V AC/DC  
 VOLTAGE PROOF = 360V AC/DC  
 CONTACT RESISTANCE = 25 mΩ MAX  
 INSULATION RESISTANCE = 100 MΩ MIN  
**MECHANICAL:**  
 DURABILITY = 500 OPERATIONS  
 INSERTION FORCE (∅0.5mm GAUGE) = 2.8N MAX  
 WITHDRAWAL FORCE (∅0.5mm GAUGE) = 0.2N MIN  
**ENVIRONMENTAL:**  
 TEMPERATURE RANGE = -55°C TO +125°C  
**PACKING:**  
 LOOSE  
 FOR COMPLETE SPECIFICATION, SEE COMPONENT SPECIFICATION C005XX (LATEST ISSUE)

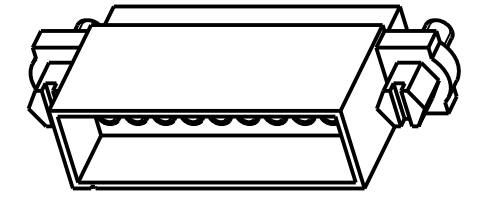

5mm POTTING WALL HEIGHT

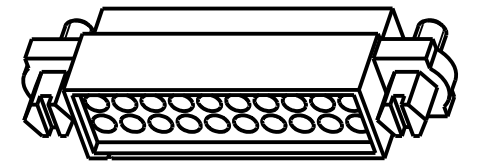

1mm POTTING WALL HEIGHT

POTTING WALL HEIGHT  
SEE ORDER CODE

PART SECTION Y-Y

ASSEMBLY PART No.	No. OF CONTACTS	DIM 'A'	DIM 'B'	DIM 'C'
M80-46506XXX	6	4.00	11.00	16.00
M80-46510XXX	10	8.00	15.00	20.00
M80-46512XXX	12	10.00	17.00	22.00
M80-46514XXX	14	12.00	19.00	24.00
M80-46518XXX	18	16.00	23.00	28.00
M80-46520XXX	20	18.00	25.00	30.00
M80-46526XXX	26	24.00	31.00	36.00
M80-46534XXX	34	32.00	39.00	44.00
M80-46542XXX	42	40.00	47.00	52.00
M80-46550XXX	50	48.00	55.00	60.00

- NOTES:**
- CONNECTORS ARE SUPPLIED WITH CONTACTS LOOSE.
  - FOR EXTRA CONTACTS, USE PART NUMBER M80-0110005 FOR M80-465XX05 AND M80-0110001 FOR M80-465XX42.
  - RECOMMENDED WIRE TYPE = BS 3G 210 TYPE A, PTFE INSULATED 22 AWG. MAX INSULATION DIAMETER = ∅1.10mm, STRIP WIRE BY 2.00mm.
  - RECOMMENDED HAND CRIMP TOOL = M22520/2-01 WITH POSITIONER T5747.
  - CONTACT INSERTION AND EXTRACTION TOOL = Z80-280.
  - INSTRUCTION SHEETS ARE AVAILABLE.

RA	7	21.01.11	11101
NAME	ISS.	DATE	C/NOTE
APPROVED:		R.ADDE	
CHECKED:		M.G.PLESTED	
DRAWN:		B. M. KENT	
CUSTOMER REF.:			
ASSEMBLY DRG.:			

**ORDER CODE:**  
**M80-465XXXXX**

TOTAL No. OF CONTACTS  
06, 10, 12, 14, 18, 20, 26, 34, 42, 50

FINISH  
05 - GOLD CLIP, GOLD SHELL  
42 - GOLD CLIP, 100% TIN SHELL

POTTING WALL HEIGHT  
BLANK = 5mm  
A = 1mm

<b>HARWIN</b>			THIS DRAWING AND ANY INFORMATION OR DESCRIPTIVE MATTER SET OUT HEREON ARE CONFIDENTIAL AND COPYRIGHT PROPERTY OF THE HARWIN GROUP AND MUST NOT BE DISCLOSED, LOANED, COPIED OR USED FOR MANUFACTURING, TENDERING OR FOR ANY OTHER PURPOSE WITHOUT THEIR WRITTEN PERMISSION.	TOLERANCES X. = ±1mm X.X = ±0.25mm X.XX = ±0.10mm X.XXX = ±0.01mm  ANGLES = ±5° UNLESS STATED	MATERIAL:  SEE ABOVE  FINISH: SEE ABOVE S/AREA: mm <sup>2</sup>	TITLE: JACKSCREW DATAMATE DIL CRIMP (LARGE BORE) POTTING WALL FEMALE ASSEMBLY  DRAWING NUMBER: <b>M80-465XXXX</b>	SHT 2 OF 2
HARWIN USA TEL: 603 893 5376 FAX: 603 893 5396 mis@harwin.com	HARWIN Europe (UK) TEL: 023 9231 4545 FAX: 023 9231 4590 mis@harwin.co.uk	HARWIN Asia TEL: +65 6 779 4909 FAX: +65 6 779 3868 mis@harwin.com.sg					