

Dual JK Positive Edge-Triggered Flip-Flops

This device is a dual edge-triggered flip-flop. Each flip-flop has individual J, K, clock, reset and preset inputs, and also complementary Q and \bar{Q} outputs.

Information at input J or K is transferred to the Q output on the positive going edge of the clock pulse. Clock triggering occurs at a voltage level of the clock pulse and is not directly related to the transition time of the positive going pulse. When the clock input is at either the high or low level, the J, K input signal has no effect.

Asynchronous preset and reset inputs will set or reset Q output respectively upon the application of low level signal. The JK design allows operation as a D-flip-flop by tying the J and K inputs together.

DV74LS109A
DV74ALS109A

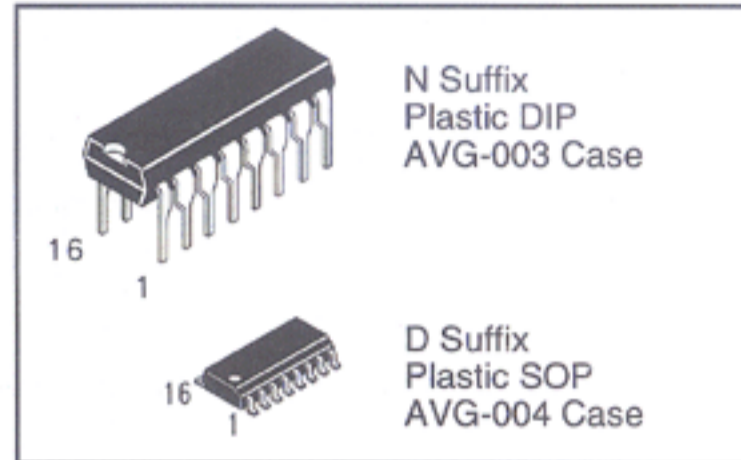

- AVG's LS operates over extended Vcc from 4.5 to 5.5 V
- AVG's LS and ALS both have guaranteed DC and AC specification over full temperature and Vcc range
- Switching specifications for ALS at 50 pF
- AVG's ALS has the lowest speed power product (4pJ per gate typical) of all logic series

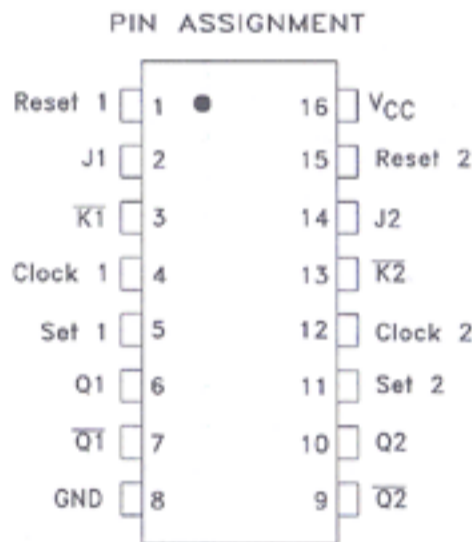
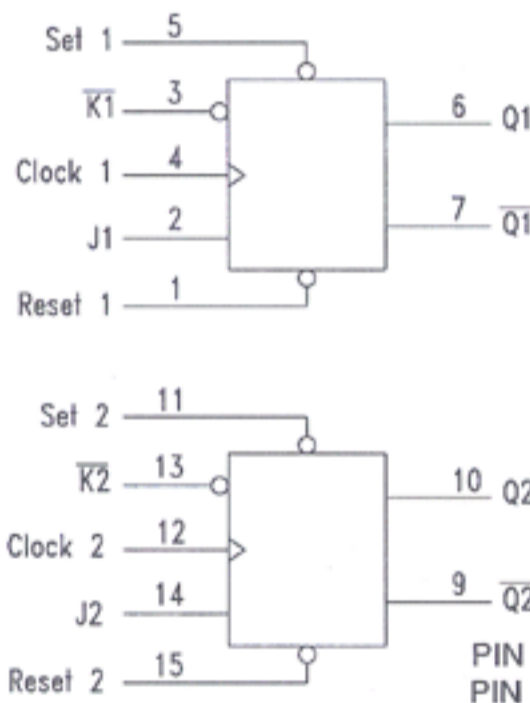

TRUTH TABLE						
Inputs					Output	
Set	Reset	Clock	J	\bar{K}	Q	\bar{Q}
L	H	X	X	X	H	L
H	L	X	X	X	L	H
L	L	X	X	X	H*	H*
H	H	↑	L	L	L	H
H	H	↑	H	L	Toggle	
H	H	↑	L	H	Q ₀	\bar{Q}_0
H	H	↑	H	H	H	L
H	H	L	X	X	Q ₀	\bar{Q}_0

H=HIGH Voltage Level
L=LOW Voltage Level
X=Immaterial
Q0=Previous Condition of Q
* Outputs are unpredictable if Set and Reset inputs go LOW simultaneously

ABSOLUTE MAXIMUM RATINGS

Maximum ratings are those values beyond which damage to the device may occur.

Symbol	Parameter	LS109A	ALS109A	Unit
V _{CC}	Supply Voltage	7.0	7.0	V
V _{IN}	Input Voltage	7.0	7.0	V
T _{STG}	Storage Temperature Range	-65 to +150	-65 to +150	°C

GUARANTEED OPERATING CONDITIONS

Symbol	Parameter	LS109A		ALS109A		Unit
		Min	Max	Min	Max	
V _{CC}	Supply Voltage	4.5	5.5	4.5	5.5	V
V _{IH}	High Level Input Voltage	2.0		2.0		V
V _{IL}	Low Level Input Voltage		0.8		0.8	V
I _{OH}	High Level Output Current		-0.4		-0.4	mA
I _{OL}	Low Level Output Current		8.0		8.0	mA
T _A	Ambient Temperature Range	-10 to +70		-10 to +70		°C

DC ELECTRICAL CHARACTERISTICS over full operating conditions

Symbol	Parameter	Condition	LS109A			ALS109A			Unit	
			Min	Typ	Max	Min	Typ	Max		
V _{IK}	Input Clamp Voltage	V _{CC} = min, I _{IN} = -18 mA			-1.5			-1.5	V	
V _{OH}	High Level Output Voltage	V _{CC} = min, I _{OH} = max	V _{CC} -2	3.5		V _{CC} -2			V	
V _{OL}	Low Level Output Voltage	V _{CC} =min		I _{OL} = 4 mA	0.25	0.4		0.25	0.4	V
				I _{OL} = 8 mA	0.35	0.5		0.35	0.5	V
I _{IH}	High Level Input Current J, K, Clock Set, Clear	V _{CC} =max, V _{IN} = 2.7V			20 40			20 40	μA	
	J, \bar{K} , Clock Set, Clear	V _{CC} =max, V _{IN} = 7V			0.1 0.2			0.1 0.2	mA	
I _{IL}	Low Level Input Current J, K, Clock Set, Clear	V _{CC} =max, V _{IN} =0.4V			-0.4 -0.8			-0.2 -0.4	mA	
I _O	Output Short Circuit Current	V _{CC} =max, V _{OUT} =2.25V	-20		-110	-30		-112	mA	
I _{CC}	Power Supply Current	V _{CC} =max			8.0		2.4	4.0	mA	

SWITCHING CHARACTERISTICS over full operating conditions

Symbol	Parameter	From	To	LS109A C _L =15 pF		ALS109A C _L =50pF R _L =500Ω		Unit
				Min	Max	Min	Max	
f _{MAX}	Maximum Clock Frequency			25		34		MHz
t _{PLH}	Propagation Delay Time Low-to-High Level Output	Clock	Any Q		25	5	16	ns
t _{PHL}	Propagation Delay Time High-to-Low Level Output	Clock	Any Q		40	5	18	ns
t _{PLH}	Propagation Delay Time Low-to-High Level Output	Set or Reset	Any Q		25	3	13	ns
t _{PHL}	Propagation Delay Time High-to-Low Level Output	Set or Reset	Any Q		40	5	15	ns

AC SETUP REQUIREMENTS

Symbol	Parameter	LS109A		ALS 109A		Unit
		MIN	MAX	MIN	MAX	
t_w	Pulse Width Set or Reset Clock	25		15		ns
t_s	Setup Time HIGH LOW	35		15		ns
t_h	Hold Time	5.0		0		ns

109A

SWITCHING WAVEFORMS

