



Integrated Device Technology, Inc.

FAST CMOS 10-BIT BUFFERS

IDT54/74FCT827AT/BT/CT/DT
IDT54/74FCT2827AT/BT/CT

FEATURES:

- **Common features:**
 - Low input and output leakage $\leq 1\mu\text{A}$ (max.)
 - Extended commercial range of -40°C to $+85^\circ\text{C}$
 - CMOS power levels
 - True TTL input and output compatibility
 - $V_{OH} = 3.3\text{V}$ (typ.)
 - $V_{OL} = 0.3\text{V}$ (typ.)
 - Meets or exceeds JEDEC standard 18 specifications
 - Product available in Radiation Tolerant and Radiation Enhanced versions
 - Military product compliant to MIL-STD-883, Class B and DESC listed (dual marked)
 - Available in DIP, SOIC, SSOP, QSOP, TSSOP, CERPACK and LCC packages
- **Features for FCT827T:**
 - A, B, C and D speed grades
 - High drive outputs (-15mA IOH, 48mA IOL)
- **Features for FCT2827T:**
 - A, B and C speed grades
 - Resistor outputs (-15mA IOH, 12mA IOL Com.) (-12mA IOH, 12mA IOL Mil.)
 - Reduced system switching noise

DESCRIPTION:

The FCT827T is built using an advanced dual metal CMOS technology.

The FCT827T/FCT2827T 10-bit bus drivers provide high-performance bus interface buffering for wide data/address paths or buses carrying parity. The 10-bit buffers have NAND-ed output enables for maximum control flexibility.

All of the FCT827T high-performance interface family are designed for high-capacitance load drive capability, while providing low-capacitance bus loading at both inputs and outputs. All inputs have clamp diodes to ground and all outputs are designed for low-capacitance bus loading in high-impedance state.

The FCT2827T has balanced output drive with current limiting resistors. This offers low ground bounce, minimal undershoot and controlled output fall times-reducing the need for external series terminating resistors. FCT2827T parts are plug-in replacements for FCT827T parts.

FUNCTIONAL BLOCK DIAGRAM

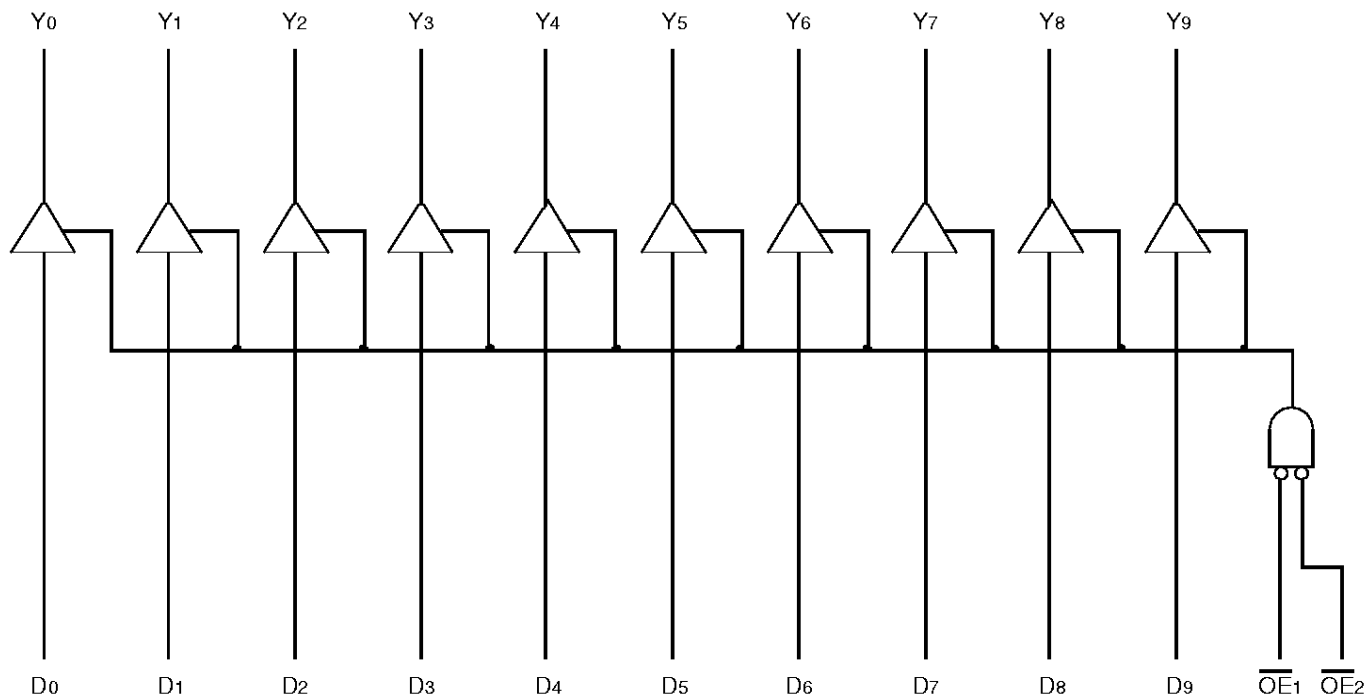

2573 drw 01

The IDT logo is a registered trademark of Integrated Device Technology, Inc.

MILITARY AND INDUSTRIAL TEMPERATURE RANGES

OCTOBER 1996

PIN CONFIGURATIONS

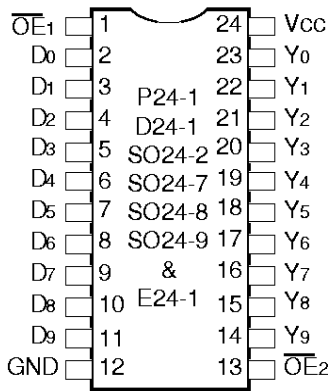

**DIP/SSOP/QSOP/
TSSOP/CERPACK
TOP VIEW**

2573 drw 02

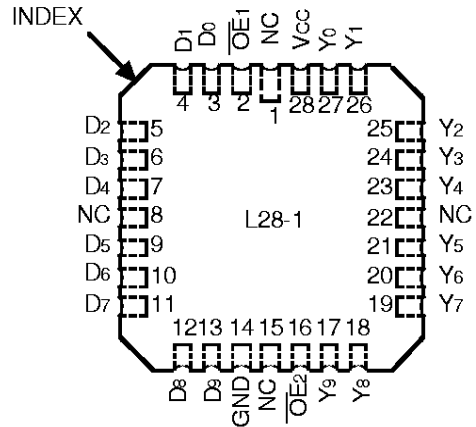

**LCC
TOP VIEW**

2573 drw 03

PIN DESCRIPTION

Names	I/O	Description
\overline{OE}_i	I	When both are LOW the outputs are enabled. When either one or both are HIGH the outputs are High Z.
D _i	I	10-bit data input.
Y _i	O	10-bit data output.

2573 tbl 01

FUNCTION TABLE⁽¹⁾

Inputs			Output	Function
\overline{OE}_1	\overline{OE}_2	D _i	Y _i	
L	L	L	L	Transparent
L	L	H	H	
H	X	X	Z	Three-State
X	H	X	Z	

NOTE:

1. H = HIGH, L = LOW, X = Don't Care, Z = High Impedance

2573 tbl 02

ABSOLUTE MAXIMUM RATINGS⁽¹⁾

Symbol	Description	Max.	Unit
V _{TERM} ⁽²⁾	Terminal Voltage with Respect to GND	-0.5 to +7.0	V
V _{TERM} ⁽³⁾	Terminal Voltage with Respect to GND	-0.5 to V _{cc} +0.5	V
T _{STG}	Storage Temperature	-65 to +150	°C
I _{OUT}	DC Output Current	-60 to +120	mA

2573 lmk 03

NOTES:

- Stresses greater than those listed under ABSOLUTE MAXIMUM RATINGS may cause permanent damage to the device. This is a stress rating only and functional operation of the device at these or any other conditions above those indicated in the operational sections of this specification is not implied. Exposure to absolute maximum rating conditions for extended periods may affect reliability. No terminal voltage may exceed V_{cc} by +0.5V unless otherwise noted.
- Input and V_{cc} terminals only.
- Outputs and I/O terminals only.

CAPACITANCE (T_A = +25°C, f = 1.0MHz)

Symbol	Parameter ⁽¹⁾	Conditions	Typ.	Max.	Unit
C _{IN}	Input Capacitance	V _{IN} = 0V	6	10	pF
C _{OUT}	Output Capacitance	V _{OUT} = 0V	8	12	pF

NOTE:

1. This parameter is measured at characterization but not tested.

2573 lmk 04

DC ELECTRICAL CHARACTERISTICS OVER OPERATING RANGE

Following Conditions Apply Unless Otherwise Specified:

Commercial: TA = -40°C to +85°C, VCC = 5.0V ± 5%; Military: TA = -55°C to +125°C, VCC = 5.0V ± 10%

Symbol	Parameter	Test Conditions ⁽¹⁾	Min.	Typ. ⁽²⁾	Max.	Unit
V _{IH}	Input HIGH Level	Guaranteed Logic HIGH Level	2.0	—	—	V
V _{IL}	Input LOW Level	Guaranteed Logic LOW Level	—	—	0.8	V
I _{IH}	Input HIGH Current ⁽⁴⁾	V _{CC} = Max. V _I = 2.7V	—	—	±1	μA
I _{IL}	Input LOW Current ⁽⁴⁾		V _I = 0.5V	—	—	
I _{OZH}	High Impedance Output Current (3-State Output pins) ⁽⁴⁾	V _{CC} = Max. V _O = 2.7V	—	—	±1	μA
I _{OZL}			V _O = 0.5V	—	—	
I _I	Input HIGH Current ⁽⁴⁾	V _{CC} = Max., V _I = V _{CC} (Max.)	—	—	±1	μA
V _{IK}	Clamp Diode Voltage	V _{CC} = Min., I _{IN} = -18mA	—	-0.7	-1.2	V
V _H	Input Hysteresis	—	—	200	—	mV
I _{CC}	Quiescent Power Supply Current	V _{CC} = Max., V _{IN} = GND or V _{CC}	—	0.01	1	mA

2573 Ink 05

OUTPUT DRIVE CHARACTERISTICS FOR FCT827T

Symbol	Parameter	Test Conditions ⁽¹⁾	Min.	Typ. ⁽²⁾	Max.	Unit	
V _{OH}	Output HIGH Voltage	V _{CC} = Min. V _{IN} = V _{IH} or V _{IL}	I _{OH} = -6mA MIL.	2.4	3.3	—	V
			I _{OH} = -8mA COM'L.	—	—	—	—
		I _{OH} = -12mA MIL. I _{OH} = -15mA COM'L.	2.0	3.0	—	V	
V _{OL}	Output LOW Voltage	V _{CC} = Min. V _{IN} = V _{IH} or V _{IL}	—	0.3	0.5	V	
I _{OS}	Short Circuit Current	V _{CC} = Max., V _O = GND ⁽³⁾	-60	-120	-225	mA	

2573 Ink 05

OUTPUT DRIVE CHARACTERISTICS FOR FCT2827T

Symbol	Parameter	Test Conditions ⁽¹⁾	Min.	Typ. ⁽²⁾	Max.	Unit
I _{ODL}	Output LOW Current	V _{CC} = 5V, V _{IN} = V _{IH} or V _{IL} , V _{OUT} = 1.5V ⁽³⁾	16	48	—	mA
I _{ODH}	Output HIGH Current	V _{CC} = 5V, V _{IN} = V _{IH} or V _{IL} , V _{OUT} = 1.5V ⁽³⁾	-16	-48	—	mA
V _{OH}	Output HIGH Voltage	V _{CC} = Min. V _{IN} = V _{IH} or V _{IL}	2.4	3.3	—	V
V _{OL}	Output LOW Voltage	V _{CC} = Min. V _{IN} = V _{IH} or V _{IL}	—	0.3	0.50	V

2573 Ink 07

NOTES:

- For conditions shown as Max. or Min., use appropriate value specified under Electrical Characteristics for the applicable device type.
- Typical values are at V_{CC} = 5.0V, +25°C ambient.
- Not more than one output should be shorted at one time. Duration of the short circuit test should not exceed one second.
- The test limit for this parameter is ±5μA at TA = -55°C.

POWER SUPPLY CHARACTERISTICS

Symbol	Parameter	Test Conditions ⁽¹⁾			Min.	Typ. ⁽²⁾	Max.	Unit
ΔI_{CC}	Quiescent Power Supply Current TTL Inputs HIGH	$V_{CC} = \text{Max.}$ $V_{IN} = 3.4V^{(3)}$			—	0.5	2.0	mA
I_{CCD}	Dynamic Power Supply Current ⁽⁴⁾	$V_{CC} = \text{Max.}$ Outputs Open $\overline{OE}_1 = \overline{OE}_2 = \text{GND}$ One Input Toggling 50% Duty Cycle	$V_{IN} = V_{CC}$ $V_{IN} = \text{GND}$	FCT827T FCT2827T	— —	0.15 0.06	0.25 0.12	mA/ MHz
I_C	Total Power Supply Current ⁽⁶⁾	$V_{CC} = \text{Max.}$ Outputs Open $f_i = 10\text{MHz}$ 50% Duty Cycle $\overline{OE}_1 = \overline{OE}_2 = \text{GND}$ One Bit Toggling	$V_{IN} = V_{CC}$ $V_{IN} = \text{GND}$ $V_{IN} = 3.4V$ $V_{IN} = \text{GND}$	FCT827T FCT2827T FCT827T FCT2827T	— — — —	1.5 0.6 1.8 0.9	3.5 2.2 4.5 3.2	mA
		$V_{CC} = \text{Max.}$ Outputs Open $f_i = 2.5\text{MHz}$ 50% Duty Cycle $\overline{OE}_1 = \overline{OE}_2 = \text{GND}$ Eight Bits Toggling	$V_{IN} = V_{CC}$ $V_{IN} = \text{GND}$ $V_{IN} = 3.4V$ $V_{IN} = \text{GND}$	FCT827T FCT2827T FCT827T FCT2827T	— — — —	3.0 1.2 5.0 3.2	6.0 ⁽⁵⁾ 3.4 ⁽⁵⁾ 14.0 ⁽⁵⁾ 11.4 ⁽⁵⁾	

NOTES:

- For conditions shown as Max. or Min., use appropriate value specified under Electrical Characteristics for the applicable device type.
- Typical values are at $V_{CC} = 5.0V$, $+25^\circ\text{C}$ ambient.
- Per TTL driven input ($V_{IN} = 3.4V$). All other inputs at V_{CC} or GND.
- This parameter is not directly testable, but is derived for use in Total Power Supply Calculations.
- Values for these conditions are examples of the I_{CC} formula. These limits are guaranteed but not tested.
- $I_C = I_{\text{QUIESCENT}} + I_{\text{INPUTS}} + I_{\text{DYNAMIC}}$
 $I_C = I_{CC} + \Delta I_{CC} D_{\text{HNT}} + I_{CCD} (f_{CP}/2 + f_i N_i)$
 I_{CC} = Quiescent Current
 ΔI_{CC} = Power Supply Current for a TTL High Input ($V_{IN} = 3.4V$)
 D_{H} = Duty Cycle for TTL Inputs High
 N_{T} = Number of TTL Inputs at D_{H}
 I_{CCD} = Dynamic Current Caused by an Input Transition Pair (HLH or LHL)
 f_{CP} = Clock Frequency for Register Devices (Zero for Non-Register Devices)
 f_i = Input Frequency
 N_i = Number of Inputs at f_i
 All currents are in milliamps and all frequencies are in megahertz.

2573 tbl 08

SWITCHING CHARACTERISTICS OVER OPERATING RANGE

Symbol	Parameter	Condition ⁽¹⁾	FCT827AT/FCT2827AT				FCT827BT/FCT2827BT				Unit
			Com'l.		Mil.		Com'l.		Mil.		
			Min. ⁽²⁾	Max.	Min. ⁽²⁾	Max.	Min. ⁽²⁾	Max.	Min. ⁽²⁾	Max.	
tPLH tPHL	Propagation Delay Di to Yi	CL = 50pF RL = 500Ω	1.5	8.0	1.5	9.0	1.5	5.0	1.5	6.5	ns
		CL = 300pF ⁽³⁾ RL = 500Ω	1.5	15.0	1.5	17.0	1.5	13.0	1.5	14.0	
tPZH tPZL	Output Enable Time \overline{OE}_i to Yi	CL = 50pF RL = 500Ω	1.5	12.0	1.5	13.0	1.5	8.0	1.5	9.0	ns
		CL = 300pF ⁽³⁾ RL = 500Ω	1.5	23.0	1.5	25.0	1.5	15.0	1.5	16.0	
tPHZ tPLZ	Output Disable Time \overline{OE}_i to Yi	CL = 5pF ⁽³⁾ RL = 500Ω	1.5	9.0	1.5	9.0	1.5	6.0	1.5	7.0	ns
		CL = 50pF RL = 500Ω	1.5	10.0	1.5	10.0	1.5	7.0	1.5	8.0	

2573 tbl 09

Symbol	Parameter	Condition ⁽¹⁾	FCT827CT/FCT2827CT				FCT827DT				Unit
			Com'l.		Mil.		Com'l.		Mil.		
			Min. ⁽²⁾	Max.	Min. ⁽²⁾	Max.	Min. ⁽²⁾	Max.	Min. ⁽²⁾	Max.	
tPLH tPHL	Propagation Delay Di to Yi	CL = 50pF RL = 500Ω	1.5	4.4	1.5	5.0	1.5	3.8	—	—	ns
		CL = 300pF ⁽³⁾ RL = 500Ω	1.5	10.0	1.5	11.0	1.5	7.5	—	—	
tPZH tPZL	Output Enable Time \overline{OE}_i to Yi	CL = 50pF RL = 500Ω	1.5	7.0	1.5	8.0	1.5	5.0	—	—	ns
		CL = 300pF ⁽³⁾ RL = 500Ω	1.5	14.0	1.5	15.0	1.5	9.0	—	—	
tPHZ tPLZ	Output Disable Time \overline{OE}_i to Yi	CL = 5pF ⁽³⁾ RL = 500Ω	1.5	5.7	1.5	6.7	1.5	4.3	—	—	ns
		CL = 50pF RL = 500Ω	1.5	6.0	1.5	7.0	1.5	4.3	—	—	

2573 tbl 10

NOTES:

1. See test circuit and waveforms.
2. Minimum limits are guaranteed but not tested on Propagation Delays.
3. These conditions are guaranteed but not tested.

TEST CIRCUITS AND WAVEFORMS

TEST CIRCUITS FOR ALL OUTPUTS

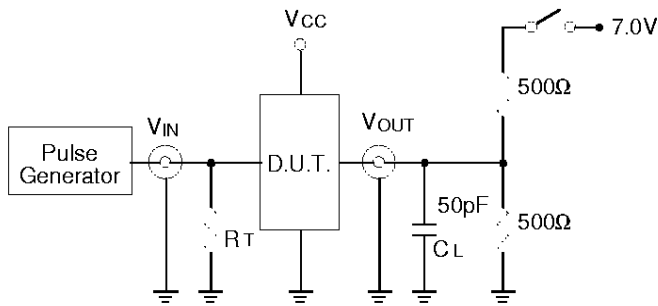

2573 drw 04

SWITCH POSITION

Test	Switch
Open Drain Disable Low Enable Low	Closed
All Other Tests	Open

DEFINITIONS:

CL = Load capacitance: includes jig and probe capacitance.
RT = Termination resistance: should be equal to Z_{OUT} of the Pulse Generator.

2573 Ink 11

SET-UP, HOLD AND RELEASE TIMES

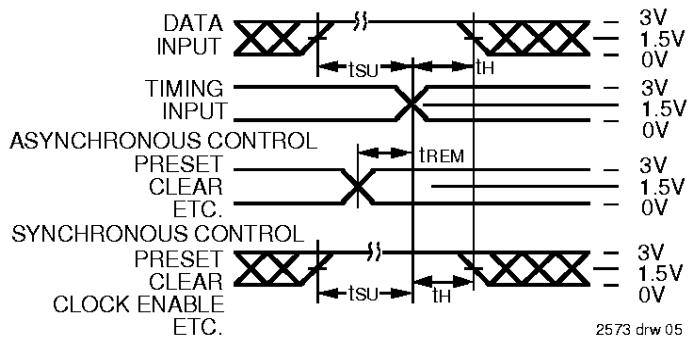

2573 drw 05

PULSE WIDTH

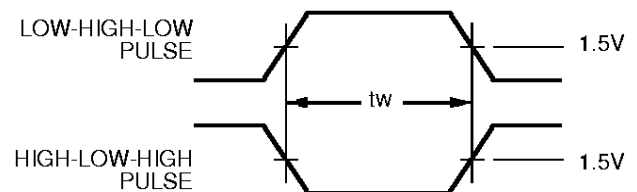

2573 drw 06

PROPAGATION DELAY

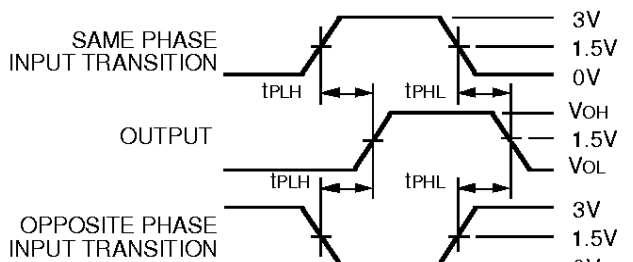

2573 drw 07

ENABLE AND DISABLE TIMES

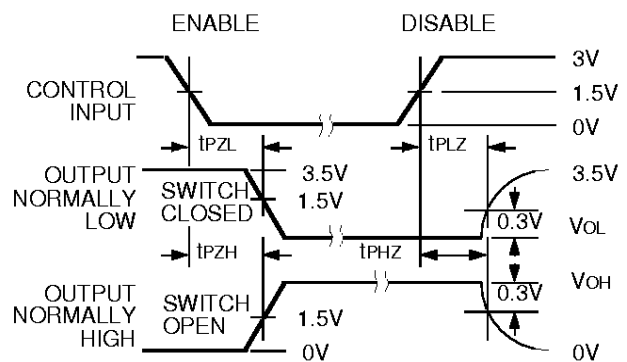

2573 drw 08

NOTES:

- Diagram shown for input Control Enable-LOW and input Control Disable-HIGH
- Pulse Generator for All Pulses: Rate ≤ 1.0MHz; t_F ≤ 2.5ns; t_R ≤ 2.5ns

ORDERING INFORMATION

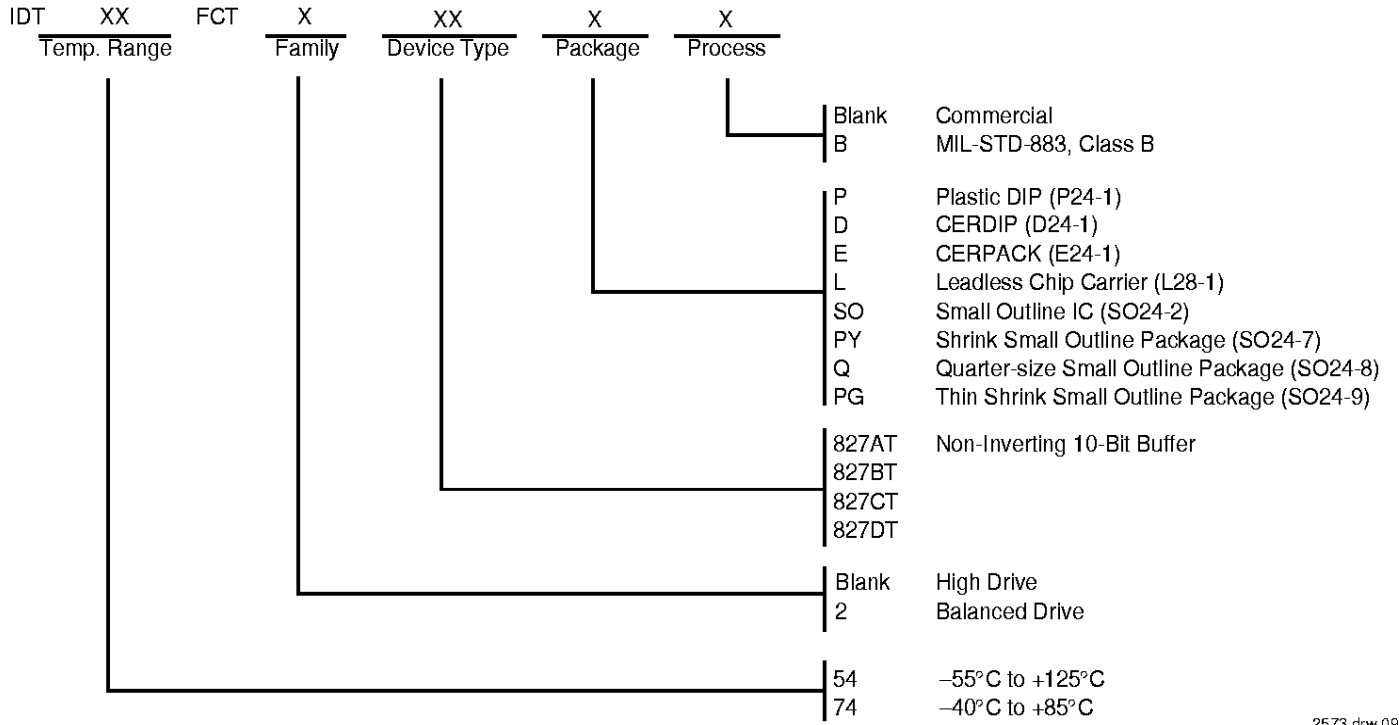

2573 drw 09