

T-64-21-51



DM54ALS153/DM74ALS153 Dual 1 of 4 Line Data Selector/Multiplexer

General Description

This Data Selector/Multiplexer contains full on-chip decoding to select one-of-four data sources as a result of a unique two-bit binary code at the Select inputs. Each of the two Data Selector/Multiplexer circuits have their own separate Data and Strobe inputs and a non-inverting output buffer. The Select inputs A and B are common to both sections. The Strobe inputs, when at the high level, disable the associated data inputs and force the corresponding output to the low state. The Select input buffers incorporate internal overlap features to ensure that select input changes do not cause invalid output transients.

Features

- Advanced oxide-isolated, ion-implanted Schottky TTL process
- Switching performance is guaranteed over full temperature and V_{CC} supply range
- Pin and functional compatible with LS family counterpart
- Improved output transient handling capability

Connection Diagram

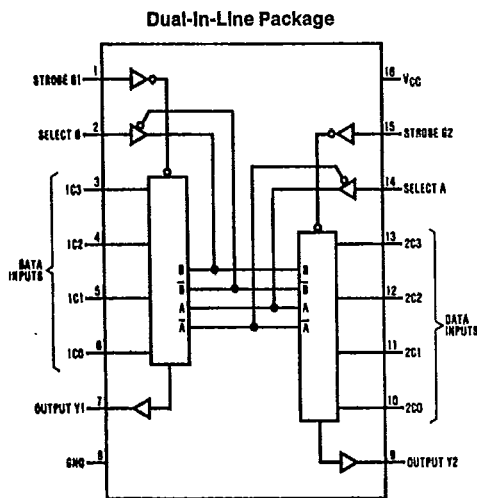

TL/F/6204-1

Order Number DM54ALS153J, DM74ALS153M,
DM74ALS153N or DM74ALS153SJ
See NS Package Number J16A, M16A, M16D or N16A

Function Table

Select Inputs		Data Inputs				Strobe	Output
B	A	C0	C1	C2	C3	G	Y
X	X	X	X	X	X	H	L
L	L	L	X	X	X	L	L
L	L	H	X	X	X	L	H
L	H	X	L	X	X	L	L
L	H	X	H	X	X	L	H
H	L	X	X	L	X	L	L
H	L	X	X	H	X	L	H
H	H	X	X	X	L	L	L
H	H	X	X	X	H	L	H

Select Inputs A and B are common to both sections.
H = High Level, L = Low Level, X = Don't Care



153

Absolute Maximum Ratings

If Military/Aerospace specified devices are required, please contact the National Semiconductor Sales Office/Distributors for availability and specifications.

Supply Voltage	7V
Input Voltage	7V
Operating Free Air Temperature Range	
DM54ALS	-55°C to +125°C
DM74ALS	0°C to +70°C
Storage Temperature Range	-65°C to +150°C
Typical θ_{JA}	
N Package	78.0°C/W
M Package	107.0°C/W

T-66-21-51

Note: The "Absolute Maximum Ratings" are those values beyond which the safety of the device cannot be guaranteed. The device should not be operated at these limits. The parametric values defined in the "Electrical Characteristics" table are not guaranteed at the absolute maximum ratings. The "Recommended Operating Conditions" table will define the conditions for actual device operation.

Recommended Operating Conditions

Symbol	Parameter	DM54ALS153			DM74ALS153			Units
		Min	Nom	Max	Min	Nom	Max	
V _{CC}	Supply Voltage	4.5	5	5.5	4.5	5	5.5	V
V _{IH}	High Level Input Voltage	2			2			V
V _{IL}	Low Level Input Voltage			0.7			0.8	V
I _{OH}	High Level Output Current			-1			-2.6	mA
I _{OL}	Low Level Output Current			12			24	mA
T _A	Free Air Operating Temperature	-55		125	0		70	°C

Electrical Characteristics

over recommended operating free air temperature range. All typical values are measured at V_{CC} = 5V, T_A = 25°C.

Symbol	Parameter	Conditions	Min	Typ	Max	Units
V _{IK}	Input Clamp Voltage	V _{CC} = 4.5V, I _{IN} = -18 mA			-1.5	V
V _{OH}	High Level Output Voltage	V _{CC} = 4.5V, I _{OH} = Max	2.4	3.2		V
		I _{OH} = -400 μA, V _{CC} = 4.5V to 5.5V	V _{CC} - 2			V
V _{OL}	Low Level Output Voltage	V _{CC} = 4.5V		0.25	0.4	V
			54/74ALS I _{OL} = 12 mA		0.35	0.5
	74ALS I _{OL} = 24 mA					V
I _I	Input Current at Max Input Voltage	V _{CC} = 5.5V, V _{IN} = 7V			0.1	mA
I _{IH}	High Level Input Current	V _{CC} = 5.5V, V _{IN} = 2.7V			20	μA
I _{IL}	Low Level Input Current	V _{CC} = 5.5V, V _{IN} = 0.4V			-0.1	mA
I _O	Output Drive Current	V _{CC} = 5.5V, V _{OUT} = 2.25V	-30		-112	mA
I _{CC}	Supply Current	V _{CC} = 5.5V All Inputs = 4.5V		7.5	14	mA

T-66-21-51

153

Switching Characteristics

over recommended operating free air temperature range (Note 1).

Symbol	Parameter	Conditions	From	To	DM54ALS153		DM74ALS153		Units
					Min	Max	Min	Max	
t _{PLH}	Propagation Delay Time Low to High Level Output	V _{CC} = 4.5V to 5.5V C _L = 50 pF R _L = 500Ω	Select	Y	5	21	5	21	ns
t _{PHL}	Propagation Delay Time High to Low Level Output		Select	Y	5	25	5	21	ns
t _{PLH}	Propagation Delay Time Low to High Level Output		Data	Y	3	12	3	10	ns
t _{PHL}	Propagation Delay Time High to Low Level Output		Data	Y	4	18	4	15	ns
t _{PLH}	Propagation Delay Time Low to High Level Output		Strobe	Y	5	18	5	18	ns
t _{PHL}	Propagation Delay Time High to Low Level Output		Strobe	Y	3	22	5	18	ns

Note 1: See Section 1 for test waveforms and output load.

Logic Diagram

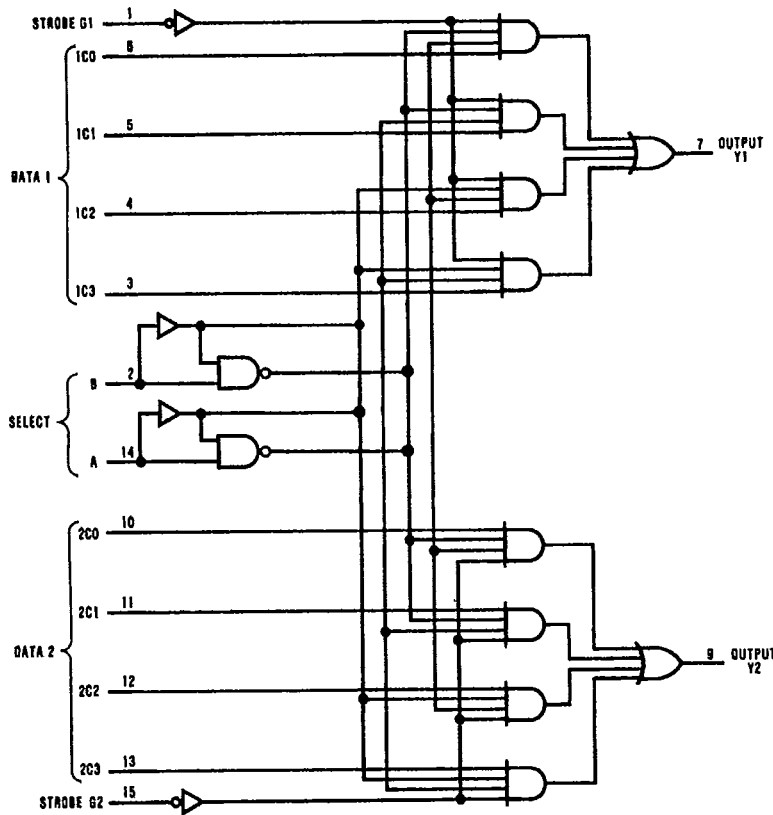

TL/F/8204-2

