



MIC2937A, 29371, 29372, 29373

750mA Low Drop Out Voltage Regulator

Preliminary Information—Production Q1 '94

General Description

The MIC2937A family are "bulletproof" efficient voltage regulators with very low dropout voltage (typically 40mV at light loads and 300mV at 500mA), and very low quiescent current (90µA typical). The quiescent current of the MIC2937A increases only slightly in dropout, thus prolonging battery life. Key MIC2937A features include protection against reversed battery, fold-back current limiting, and automotive "load dump" protection (60V positive transient).

The MIC2937 is available in several configurations. The MIC2937A-xx devices are three pin fixed voltage regulators. The MIC29371 is a fixed regulator offering logic compatible ON/OFF switching input and an error flag output. This flag may also be used as a power-on reset signal. A logic-compatible shutdown input is provided on the adjustable MIC29372, which enables the regulator to be switched on and off. The MIC29373 is a five pin adjustable version that includes an error flag output that warns of a low output voltage, which is often due to failing batteries on the input.

Features

- High output voltage accuracy
- Guaranteed 750mA output
- Low quiescent current
- Low dropout voltage
- Extremely tight load and line regulation
- Very low temperature coefficient
- Current and thermal limiting
- Input can withstand -20V reverse battery and +60V positive transients
- Error flag warns of output dropout
- Logic-controlled electronic shutdown
- Output programmable from 1.24V to 26V(MIC29372/ MIC29373)
- Available in TO-220, TO-263, TO-220-5, and TO-263-5 packages.

Applications

- Battery Powered Equipment
- Cellular Telephones
- Laptop, Notebook, and Palmtop Computers
- PCMCIA V_{CC} and V_{PP} Regulation/Switching
- Bar Code Scanners
- Automotive Electronics
- SMPS Post-Regulator/ DC to DC Modules
- High Efficiency Linear Power Supplies

Pin Configuration

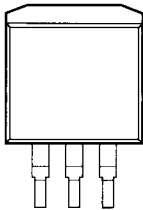

INPUT GROUND OUTPUT

TO-263 Package
(MIC2937A-xxBU)

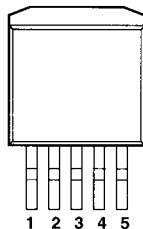

1 2 3 4 5
TO-263-5 Package
(MIC29371/29372/29373BU)

Five Lead Package Pin Functions:

MIC29371	MIC29372	MIC29373
1) Error	Adjust	Error
2) Input	Shutdown	Adjust
3) Ground	Ground	Ground
4) Output	Input	Input
5) Shutdown	Output	Output

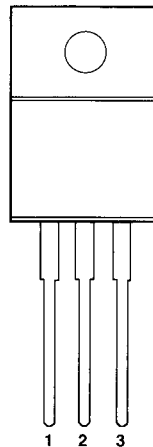

1 2 3
INPUT GROUND OUTPUT

TO-220 Package
(MIC2937A-xxBT)

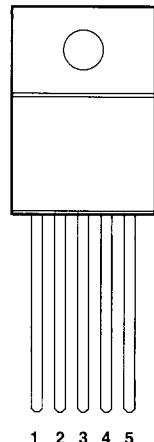

1 2 3 4 5

TO-220-5 Package
(MIC29371/29372/29373BT)

The TAB is Ground on the TO-220 and TO-263 packages.

Ordering Information			
Part Number	Voltage	Temperature Range*	Package
MIC2937A-3.3BU	3.3	-40°C to +125°C	TO-263-3
MIC2937A-3.3BT	3.3	-40°C to +125°C	TO-220
MIC2937A-5.0BU	5.0	-40°C to +125°C	TO-263-3
MIC2937A-5.0BT	5.0	-40°C to +125°C	TO-220
MIC2937A-12BU	12	-40°C to +125°C	TO-263-3
MIC2937A-12BT	12	-40°C to +125°C	TO-220
MIC2937A-15BU	15	-40°C to +125°C	TO-263-3
MIC2937A-15BT	15	-40°C to +125°C	TO-220
MIC29371-3.3BT	3.3	-40°C to +125°C	TO-220-5
MIC29371-3.3BU	3.3	-40°C to +125°C	TO-263-5
MIC29371-5.0BT	5.0	-40°C to +125°C	TO-220-5
MIC29371-5.0BU	5.0	-40°C to +125°C	TO-263-5
MIC29371-12BT	12	-40°C to +125°C	TO-220-5
MIC29371-12BU	12	-40°C to +125°C	TO-263-5
MIC29371-15BT	15	-40°C to +125°C	TO-220-5
MIC29371-15BU	15	-40°C to +125°C	TO-263-5
MIC29372BT	Adj	-40°C to +125°C	TO-220-5
MIC29372BU	Adj	-40°C to +125°C	TO-263-5
MIC29373BT	Adj	-40°C to +125°C	TO-220-5
MIC29373BU	Adj	-40°C to +125°C	TO-263-5

* Junction temperatures

Absolute Maximum Ratings

If Military/Aerospace specified devices are required, contact your local Micrel representative/distributor for availability and specifications.

Power Dissipation (Note 1)	Internally Limited
Lead Temperature (Soldering, 5 seconds)	260°C
Storage Temperature Range	-65°C to +150°C
Operating Junction Temperature Range	-40°C to +125°C
Input Supply Voltage	-20V to +60V
Operating Input Supply Voltage	2V [†] to 26V
Adjust Input Voltage (Notes 9 and 10)	-1.5V to +26V
Shutdown Input Voltage	-0.3V to +30V
Error Comparator Output Voltage	-0.3V to +30V
ESD Rating	>±2000V

[†] Across the full operating temperature, the minimum input voltage range for full output current is 4.3V to 26V. Output will remain in-regulation at lower output voltages and low current loads down to an input of 2V at 25°C.

Electrical Characteristics

Limits in standard typeface are for $T_J = 25^\circ\text{C}$ and limits in **boldface** apply over the full operating temperature range. Unless otherwise specified, $V_{IN} = V_{OUT} + 1\text{V}$, $I_L = 5\text{mA}$, $C_L = 10\mu\text{F}$. The MIC29372 and MIC29373 are programmed for a 5V output voltage, and $V_{SHUTDOWN} \leq 0.6\text{V}$ (MIC29372 only).

Symbol	Parameter	Conditions	Min	Typical	Max	Units
V_O	Output Voltage (5.0 or adjustable versions)	$5\text{mA} \leq I_L \leq 500\text{mA}$	4.950 4.900 4.880	5.00 5.00	5.050 5.100 5.120	V
	Output Voltage Accuracy	Variation from designed V_{OUT} $5\text{mA} \leq I_L \leq 500\text{mA}$	-1 -2 -2.5		1 2 2.5	%
$\frac{\Delta V_O}{\Delta T}$	Output Voltage Temperature Coef.	(Note 2)		20	100	ppm/ $^\circ\text{C}$
$\frac{\Delta V_O}{V_O}$	Line Regulation	$V_{IN} = V_{OUT} + 1\text{V}$ to 26V		0.03	0.10 0.40	%
$\frac{\Delta V_O}{V_O}$	Load Regulation	$I_L = 5$ to 750mA (Note 3)		0.04	0.16 0.20	%
$V_{IN} - V_O$	Dropout Voltage (Note 4)	$I_L = 5\text{mA}$		60	100 150	mV
		$I_L = 100\text{mA}$		150	200 320	
		$I_L = 500\text{mA}$		300	450 600	
		$I_L = 750\text{mA}$		370		
I_{GND}	Ground Pin Current (Note 5)	$I_L = 5\text{mA}$		90	150 180	μA
		$I_L = 100\text{mA}$		1	2 3	mA
		$I_L = 500\text{mA}$		8	13 16	
		$I_L = 750\text{mA}$		15		
I_{GNDDO}	Ground Pin Current at Dropout (Note 5)	$V_{IN} = 0.5\text{V}$ less than designed V_{OUT} ($V_{OUT} \geq 3.3\text{V}$)		180	300	μA
I_{LIMIT}	Current Limit	$V_{OUT} = 0\text{V}$ (Note 6)		1.0	1.5 2	A
$\frac{\Delta V_O}{\Delta P_D}$	Thermal Regulation	(Note 7)		0.05	0.2	%/W
e_n	Output Noise Voltage (10Hz to 100kHz) $I_L = 100\text{mA}$	$C_L = 2.2\mu\text{F}$		400		$\mu\text{V RMS}$
		$C_L = 33\mu\text{F}$		260		

Electrical Characteristics (Continued)**MIC29372/MIC29373**

Parameter	Conditions				Units
		Min	Typical	Max	
Reference Voltage		1.210 1.200	1.235	1.260 1.270	V V max
Reference Voltage	(Note 8)	1.185		1.285	V
Adjust Pin Bias Current			20	40 60	nA
Reference Voltage Temperature Coefficient	(Note 7)		20		ppm/°C
Adjust Pin Bias Current Temperature Coefficient			0.1		nA/°C

Error Comparator MIC29371/29373

Output Leakage Current	$V_{OH} = 30V$		0.01	1.00 2.00	μA
Output Low Voltage	$V_{IN} = 4.5V$ $I_{OL} = 250\mu A$		150	250 400	mV
Upper Threshold Voltage	(Note 9)	40 25	60		mV
Lower Threshold Voltage	(Note 9)		75	95 140	mV
Hysteresis	(Note 9)		15		mV

Shutdown Input MIC29371/MIC29372

Input Logic Voltage Low (ON)	High (OFF)	2.0	1.3	0.7	V
Shutdown Pin Input Current	$V_{SHUTDOWN} = 2.4V$		30	50 100	μA
	$V_{SHUTDOWN} = 30V$		450	600 750	μA
Regulator Output Current in Shutdown	(Note 10)		3	10 20	μA

Note 1: Absolute maximum ratings indicate limits beyond which damage to the component may occur. Electrical specifications do not apply when operating the device outside of its rated operating conditions. The maximum allowable power dissipation is a function of the maximum junction temperature, $T_{J(MAX)}$, the junction-to-ambient thermal resistance, θ_{JA} , and the ambient temperature, T_A . The maximum allowable power dissipation at any ambient temperature is calculated using: $P_{(MAX)} = (T_{J(MAX)} - T_A) / \theta_{JA}$. Exceeding the maximum allowable power dissipation will result in excessive die temperature, and the regulator will go into thermal shutdown.

Note 2: Output voltage temperature coefficient is defined as the worst case voltage change divided by the total temperature range.

Note 3: Regulation is measured at constant junction temperature using low duty cycle pulse testing. Changes in output voltage due to heating effects are covered by the thermal regulation specification.

Note 4: Dropout Voltage is defined as the input to output differential at which the output voltage drops 100 mV below its nominal value measured at 1V differential. At low values of programmed output voltage, the minimum input supply voltage of 4.3V over temperature must be taken into account. The MIC2937A operates down to 2V of input at reduced output current at 25°C.

Note 5: Ground pin current is the regulator quiescent current. The total current drawn from the source is the sum of the load current plus the ground pin current.

Note 6: The MIC2937A features fold-back current limiting. The short circuit ($V_{OUT} = 0V$) current limit is less than the maximum current with normal output voltage.

Note 7: Thermal regulation is defined as the change in output voltage at a time T after a change in power dissipation is applied, excluding load or line regulation effects. Specifications are for a 200mA load pulse at $V_{IN} = 20V$ (a 4W pulse) for $T = 10ms$.

Note 8: $V_{REF} \leq V_{OUT} \leq (V_{IN} - 1V)$, $4.3V \leq V_{IN} \leq 26V$, $5mA < I_L \leq 750mA$, $T_J \leq T_{JMAX}$.

Note 9: Comparator thresholds are expressed in terms of a voltage differential at the Adjust terminal below the nominal reference voltage measured at 6V input (for a 5V regulator). To express these thresholds in terms of output voltage change, multiply by the error amplifier gain = $V_{OUT} / V_{REF} = (R1 + R2) / R2$. For example, at a programmed output voltage of 5V, the Error output is guaranteed to go low when the output drops by $95mV \times 5V / 1.235V = 384mV$. Thresholds remain constant as a percent of V_{OUT} as V_{OUT} is varied, with the dropout warning occurring at typically 5% below nominal, 7.5% guaranteed.

Note 10: Circuit of Figure 3 with $R1 \geq 150k\Omega$. $V_{SHUTDOWN} \geq 2V$ and $V_{IN} \leq 26V$, $V_{OUT} = 0$.

Note 11: When used in dual supply systems where the regulator load is returned to a negative supply, the output voltage must be diode clamped to ground.

Note 12: Maximum positive supply voltage of 60V must be of limited duration ($< 100ms$) and duty cycle ($\leq 1\%$). The maximum continuous supply voltage is 26V.

Schematic Diagram

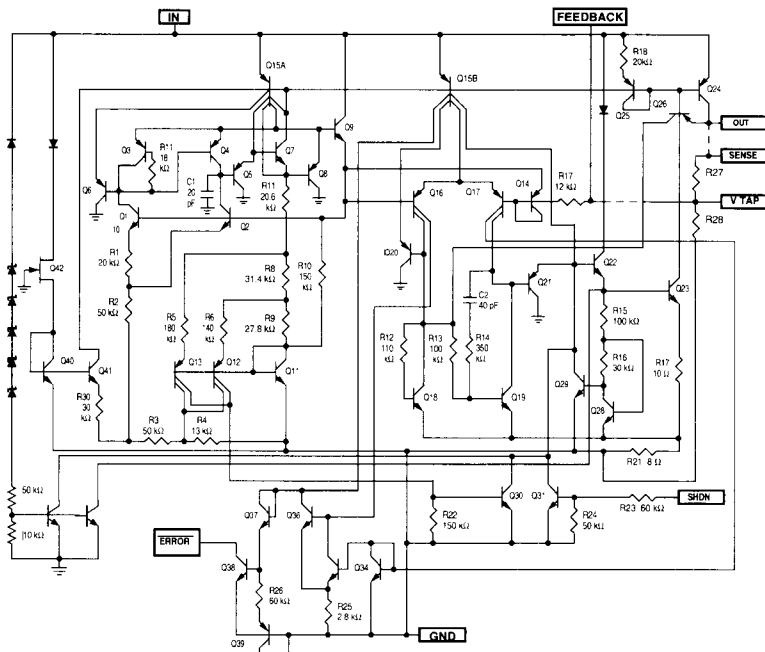

Typical Characteristics

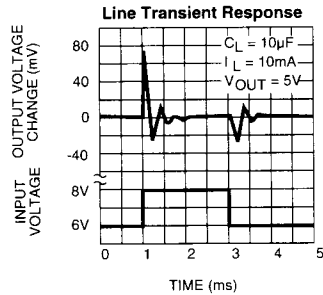
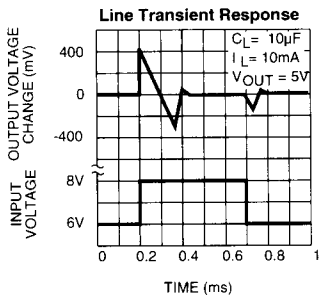
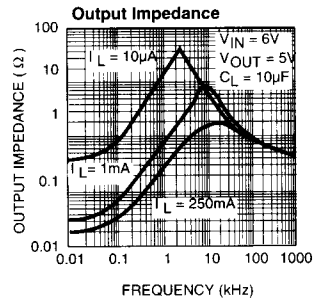
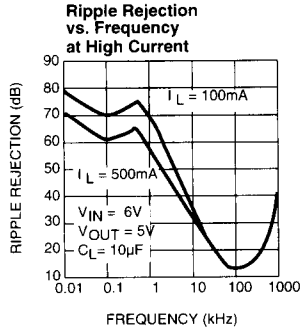
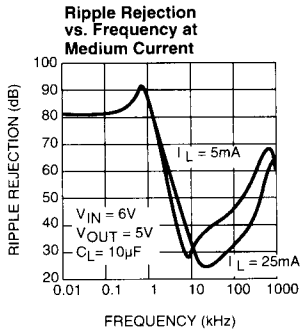
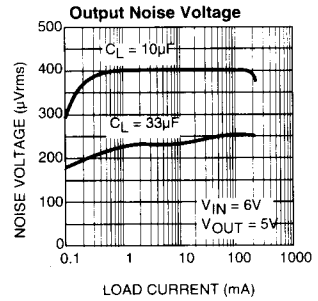
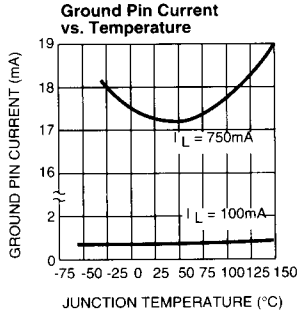
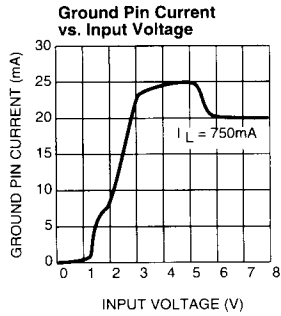
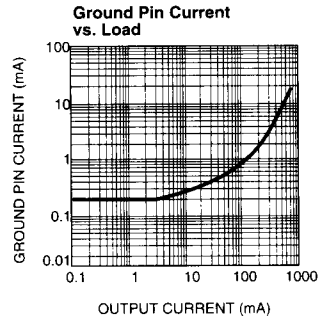
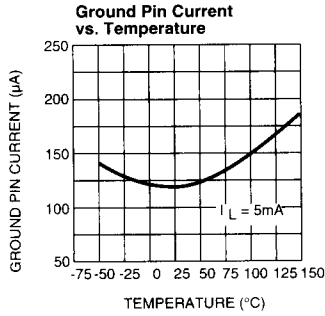
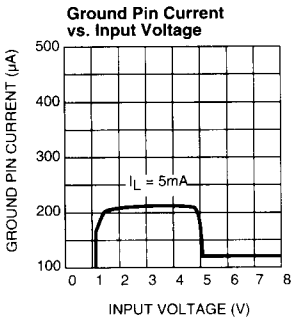

Typical Characteristics, Continued

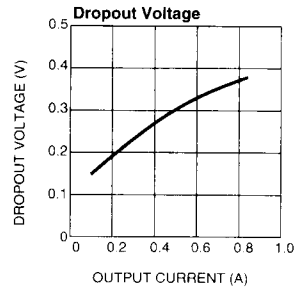
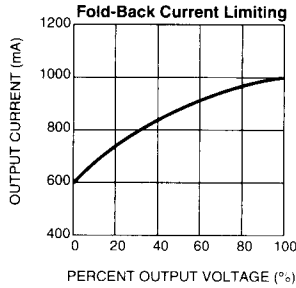
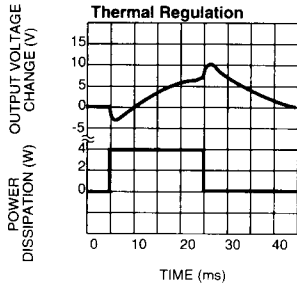
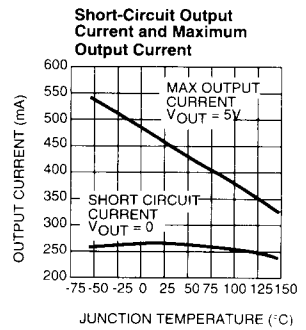
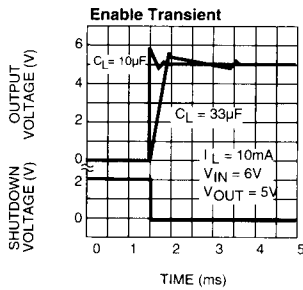
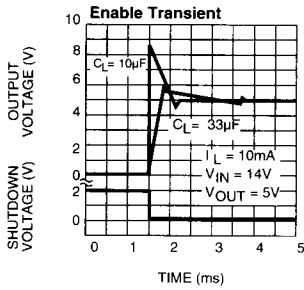
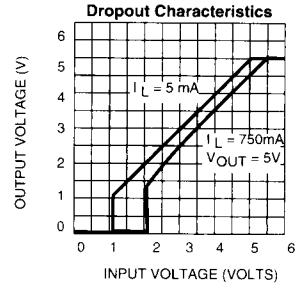
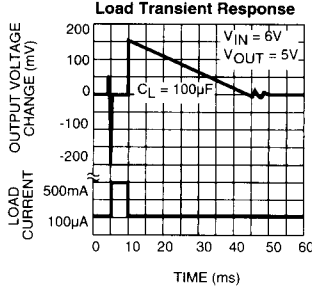
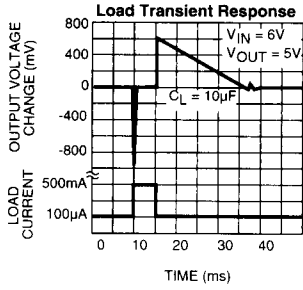

Applications Information

External Capacitors

A 10 μ F (or greater) capacitor is required between the MIC2937A output and ground to prevent oscillations due to instability. Most types of tantalum or aluminum electrolytics will be adequate; film types will work, but are costly and therefore not recommended. Many aluminum electrolytics have electrolytes that freeze at about -30°C , so solid tantalums are recommended for operation below -25°C . The important parameters of the capacitor are an effective series resistance of about 5 Ω or less and a resonant frequency above 500kHz. The value of this capacitor may be increased without limit.

At lower values of output current, less output capacitance is required for output stability. The capacitor can be reduced to 0.5 μ F for current below 10mA or 0.15 μ F for currents below 1 mA. Adjusting the MIC29372/29373 to voltages below 5V runs the error amplifier at lower gains so that more output capacitance is needed. For the worst-case situation of a 750mA load at 1.23V output (Output shorted to Adjust) a 22 μ F (or greater) capacitor should be used.

The MIC2937A will remain stable and in regulation with no load in addition to the internal voltage divider, unlike many other voltage regulators. This is especially important in CMOS RAM keep-alive applications. When setting the output voltage of the MIC29372/29373 version with external resistors, a minimum load of 1mA is recommended.

A 1 μ F capacitor should be placed from the input to ground if there is more than 10 inches of wire between the input and the AC filter capacitor or if a battery is used as the input.

Stray capacitance to the MIC29372/29373 Adjust terminal (pin 7) can cause instability. This may especially be a problem when using high value external resistors to set the output voltage. Adding a 100pF capacitor between Output and Adjust and increasing the output capacitor to at least 22 μ F will remedy this.

Error Detection Comparator Output (MIC29371/ MIC29373)

A logic low output will be produced by the comparator whenever the MIC29371/29373 output falls out of regulation by more than approximately 5%. This figure is the comparator's built-in offset of about 60mV divided by the 1.235V reference voltage. (Refer to the block diagram on Page 1). This trip level remains "5% below normal" regardless of the programmed output voltage of the MIC29371/29373. For example, the error flag trip level is typically 4.75V for a 5V output or 11.4V for a 12V output. The out of regulation condition may be due either to low input voltage, extremely high input voltage, current limiting, or thermal limiting.

Figure 1 is a timing diagram depicting the $\overline{\text{ERROR}}$ signal and the regulated output voltage as the MIC29371/29373 input is ramped up and down. The $\overline{\text{ERROR}}$ signal becomes valid (low) at about 1.3V input. It goes high at about 5V input (the input voltage at which $V_{\text{OUT}} = 4.75$). Since the MIC29371/29373's dropout voltage is load-dependent (see curve in

Typical Performance Characteristics), the input voltage trip point (about 5V) will vary with the load current. The output voltage trip point (approximately 4.75V) does not vary with load.

The error comparator has an open-collector output which requires an external pull-up resistor. Depending on system requirements, this resistor may be returned to the 5V output or some other supply voltage. In determining a value for this resistor, note that while the output is rated to sink 250 μ A, this sink current adds to battery drain in a low battery condition. Suggested values range from 100k to 1M Ω . The resistor is not required if this output is unused.

In shutdown mode, $\overline{\text{ERROR}}$ will go high if it has been pulled up to an external supply. To avoid this invalid response, $\overline{\text{ERROR}}$ should be pulled up to V_{OUT} .

Programming the Output Voltage (MIC29372/ MIC29373)

The MIC29372/29373 may be programmed for any output voltage between its 1.235V reference and its 26V maximum rating. An external pair of resistors is required, as shown in Figure 3.

The complete equation for the output voltage is

$$V_{\text{OUT}} = V_{\text{REF}} \times \{ 1 + R_1/R_2 \} + I_{\text{FB}} R_1$$

where V_{REF} is the nominal 1.235 reference voltage and I_{FB} is the Adjust pin bias current, nominally 20nA. The minimum recommended load current of 1 μ A forces an upper limit of 1.2M Ω on the value of R_2 , if the regulator must work with no load (a condition often found in CMOS in standby), I_{FB} will produce a 2% typical error in V_{OUT} which may be eliminated at room temperature by trimming R_1 . For better accuracy, choosing $R_2 = 100\text{k}$ reduces this error to 0.17% while increasing the resistor program current to 12 μ A. Since the MIC29372/29373 typically draws 100 μ A at no load with SHUTDOWN open-circuited, this is a negligible addition.

Reducing Output Noise

In reference applications it may be advantageous to reduce the AC noise present at the output. One method is to reduce the regulator bandwidth by increasing the size of the output capacitor. This is relatively inefficient, as increasing the capacitor from 1 μ F to 220 μ F only decreases the noise from 430 μ V to 160 μ V_{RMS} for a 100kHz bandwidth at 5V output. Noise can be reduced by a factor of four with the adjustable

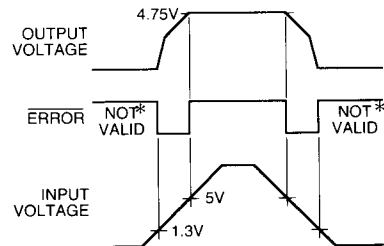

* SEE APPLICATIONS INFORMATION

Figure 1. $\overline{\text{ERROR}}$ Output Timing

regulators with a bypass capacitor across R_1 , since it reduces the high frequency gain from 4 to unity. Pick

$$C_{BYPASS} \cong \frac{1}{2\pi R_1 \cdot 200 \text{ Hz}}$$

or about $0.01\mu\text{F}$. When doing this, the output capacitor must be increased to $10\mu\text{F}$ to maintain stability. These changes reduce the output noise from $430\mu\text{V}$ to $100\mu\text{V}_{\text{RMS}}$ for a 100 kHz bandwidth at 5V output. With the bypass capacitor added, noise no longer scales with output voltage so that improvements are more dramatic at higher output voltages.

Automotive Applications

The MIC2937A is ideally suited for automotive applications for a variety of reasons. It will operate over a wide range of input voltages with very low dropout voltages (40mV at light loads), and very low quiescent currents ($100\mu\text{A}$ typical). These features are necessary for use in battery powered systems, such as automobiles. It is a "bulletproof" device with the ability to survive both reverse battery (negative transients up to 20V below ground), and load dump (positive transients up to 60V) conditions. A wide operating temperature range with low temperature coefficients is yet another reason to use these versatile regulators in automotive designs.

Typical Applications

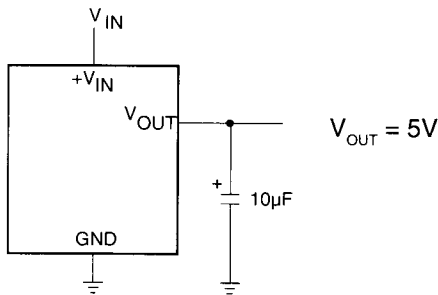
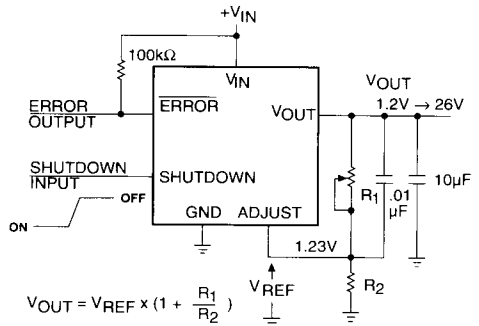
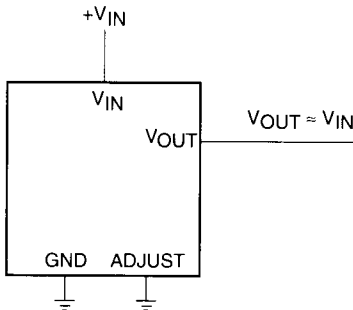

Figure 2. MIC2937A-5.0 Fixed +5V Regulator



ERROR OUTPUT ON MIC29373 ONLY
SHUTDOWN INPUT ON MIC29372 ONLY

Figure 3. MIC29372/29373 Adjustable Regulator



*MINIMUM INPUT-OUTPUT VOLTAGE RANGES FROM 40mV TO 400mV , DEPENDING ON LOAD CURRENT.

Figure 4. MIC29372/29373 Wide Input Voltage Range Current Limiter

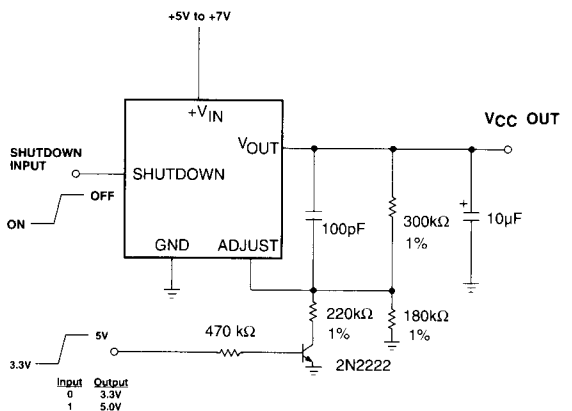

SHUTDOWN PIN LOW= ENABLE OUTPUT. Q1 ON = 3.3V, Q1 OFF = 5.0V.

Figure 5. MIC29372 5.0V or 3.3V Selectable Regulator with Shutdown.