

# DM54L93 Decade, Divide-by-12, and Binary Counters

## General Description

Each of these monolithic counters contains four master-slave flip-flops and additional gating to provide a divide-by-two counter and a three-stage binary counter for which the count cycle length is divide-by-eight.

To use their maximum count length (decade, divide-by-twelve, or four-bit binary), the B input is connected to the Q<sub>A</sub> output. The input count pulses are applied to input A and the outputs are as described in the appropriate truth table.

## Features

- Typical power dissipation 16 mW
- Count frequency 15 MHz

## Connection Diagram

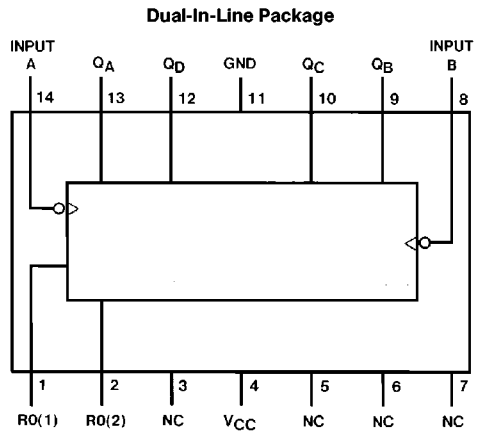

Order Number DM54L93J or DM54L93W  
See NS Package Number J14A or W14B

## Function Tables

**COUNT SEQUENCE**  
(See Note A)

Count	Output			
	Q <sub>D</sub>	Q <sub>C</sub>	Q <sub>B</sub>	Q <sub>A</sub>
0	L	L	L	L
1	L	L	L	H
2	L	L	H	L
3	L	L	H	H
4	L	H	L	L
5	L	H	L	H
6	L	H	H	L
7	L	H	H	H
8	H	L	L	L
9	H	L	L	H
10	H	L	H	L
11	H	L	H	H
12	H	H	L	L
13	H	H	L	H
14	H	H	H	L
15	H	H	H	H

**RESET/COUNT TRUTH TABLE (Note B)**

Reset Inputs		Output			
R0(1)	R0(2)	Q <sub>D</sub>	Q <sub>C</sub>	Q <sub>B</sub>	Q <sub>A</sub>
H	H	L	L	L	L
L	X	COUNT			
X	L	COUNT			

**Note A:** Output Q<sub>A</sub> is connected to input B

**Note B:** H = High Level, L = Low Level, X = Don't Care.

DM54L93 Decade, Divide-by-12, and Binary Counters

## Absolute Maximum Ratings (Note)

If Military/Aerospace specified devices are required, please contact the National Semiconductor Sales Office/Distributors for availability and specifications.

Supply Voltage	8V
Input Voltage	5.5V
Operating Free Air Temperature Range	
DM54L	-55°C to +125°C
Storage Temperature Range	-65°C to +150°C

Note: The "Absolute Maximum Ratings" are those values beyond which the safety of the device cannot be guaranteed. The device should not be operated at these limits. The parametric values defined in the "Electrical Characteristics" table are not guaranteed at the absolute maximum ratings. The "Recommended Operating Conditions" table will define the conditions for actual device operation.

## Recommended Operating Conditions

Symbol	Parameter	DM54L93			Units
		Min	Nom	Max	
V <sub>CC</sub>	Supply Voltage	4.5	5	5.5	V
V <sub>IH</sub>	High Level Input Voltage	2			V
V <sub>IL</sub>	Low Level Input Voltage			0.7	V
I <sub>OH</sub>	High Level Output Current			-0.2	mA
I <sub>OL</sub>	Low Level Output Current			2	mA
f <sub>CLK</sub>	Clock Frequency (Note 5)	0		6	MHz
t <sub>w</sub>	Pulse Width (Note 5)	A	90		ns
		B	90		
		Reset	200		
t <sub>REL</sub>	Reset Release time (Note 5)	200			ns
T <sub>A</sub>	Free Air Operating Temperature	-55		125	°C

## Electrical Characteristics over recommended operating free air temperature (unless otherwise noted)

Symbol	Parameter	Conditions	Min	Typ (Note 1)	Max	Units
V <sub>OH</sub>	High Level Output Voltage	V <sub>CC</sub> = Min, I <sub>OH</sub> = Max V <sub>IL</sub> = Max, V <sub>IH</sub> = Min	2.4	3.4		V
V <sub>OL</sub>	Low Level Output Voltage	V <sub>CC</sub> = Min, I <sub>OL</sub> = Max V <sub>IL</sub> = Max, V <sub>IH</sub> = Min (Note 4)		0.15	0.3	V
I <sub>I</sub>	Input Current @ Max Input Voltage	V <sub>CC</sub> = Max V <sub>I</sub> = 5.5V	Reset		0.1	mA
			A		0.2	
			B		0.2	
I <sub>IH</sub>	High Level Input Current	V <sub>CC</sub> = Max V <sub>I</sub> = 2.4V	Reset		10	μA
			A		20	
			B		20	
I <sub>IL</sub>	Low Level Input Current	V <sub>CC</sub> = Max V <sub>I</sub> = 0.3V	Reset		-0.18	mA
			A		-0.36	
			B		-0.36	
I <sub>OS</sub>	Short Circuit Output Current	V <sub>CC</sub> = Max (Note 2)	-3		-15	mA
I <sub>CC</sub>	Supply Current	V <sub>CC</sub> = Max (Note 3)			5.5	mA

Note 1: All typicals are at V<sub>CC</sub> = 5V, T<sub>A</sub> = 25°C.

Note 2: Not more than one output should be shorted at a time.

Note 3: I<sub>CC</sub> is measured with all outputs open, R0 inputs grounded following momentary connection to 4.5V and all other inputs grounded.

Note 4: Q<sub>A</sub> outputs are tested at I<sub>OL</sub> = max plus the limit value of I<sub>IL</sub> for the B input. This permits driving the B input while maintaining full fan-out capability.

Note 5: T<sub>A</sub> = 25°C and V<sub>CC</sub> = 5V.

**Switching Characteristics** at  $V_{CC} = 5V$  and  $T_A = 25^\circ C$  (See Section 1 for Test Waveforms and Output Load)

Symbol	Parameter	From (Input) To (Output)	$R_L = 4\text{ k}\Omega, C_L = 50\text{ pF}$		Units
			Min	Max	
$f_{MAX}$	Maximum Clock Frequency	A to $Q_A$	6		MHz
$t_{PLH}$	Propagation Delay Time Low to High Level Output	A to $Q_D$		400	ns
$t_{PHL}$	Propagation Delay Time High to Low Level Output	A to $Q_D$		400	ns

**Logic Diagram**

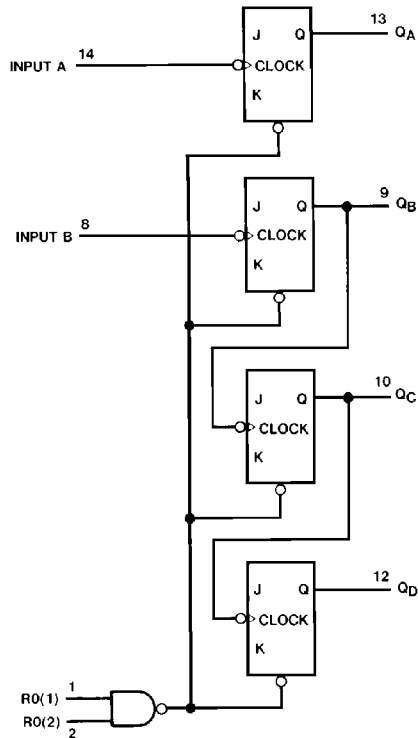

TL/F/6637-2

The J and K inputs shown without connection are for reference only and are functionally at a high level.

**Physical Dimensions** inches (millimeters)

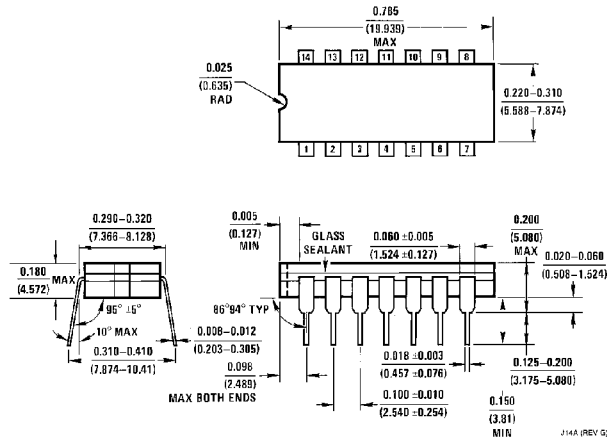

**14-Lead Ceramic Dual-In-Line Package (J)**  
**Order Number DM54L93J**  
**NS Package Number J14A**

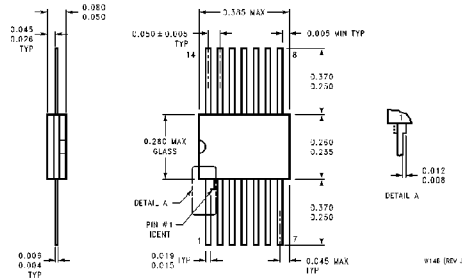

**14-Lead Ceramic Flat Package (W)**  
**Order Number DM54L93W**  
**NS Package Number W14B**

**LIFE SUPPORT POLICY**

NATIONAL'S PRODUCTS ARE NOT AUTHORIZED FOR USE AS CRITICAL COMPONENTS IN LIFE SUPPORT DEVICES OR SYSTEMS WITHOUT THE EXPRESS WRITTEN APPROVAL OF THE PRESIDENT OF NATIONAL SEMICONDUCTOR CORPORATION. As used herein:

1. Life support devices or systems are devices or systems which, (a) are intended for surgical implant into the body, or (b) support or sustain life, and whose failure to perform, when properly used in accordance with instructions for use provided in the labeling, can be reasonably expected to result in a significant injury to the user.
2. A critical component is any component of a life support device or system whose failure to perform can be reasonably expected to cause the failure of the life support device or system, or to affect its safety or effectiveness.



**National Semiconductor Corporation**  
 1111 West Bardin Road  
 Arlington, TX 76017  
 Tel: 1(800) 272-9959  
 Fax: 1(800) 737-7018

**National Semiconductor Europe**  
 Fax: (+49) 0-180-530 85 86  
 Email: onjwgs@tevm2.nsc.com  
 Deutsch Tel: (+49) 0-180-530 85 85  
 English Tel: (+49) 0-180-532 78 32  
 Français Tel: (+49) 0-180-532 93 58  
 Italiano Tel: (+49) 0-180-534 16 80

**National Semiconductor Hong Kong Ltd.**  
 13th Floor, Straight Block,  
 Ocean Centre, 5 Canton Rd.  
 Tsimshatsui, Kowloon  
 Hong Kong  
 Tel: (852) 2737-1600  
 Fax: (852) 2736-9960

**National Semiconductor Japan Ltd.**  
 Tel: 81-043-299-2309  
 Fax: 81-043-299-2408

National does not assume any responsibility for use of any circuitry described, no circuit patent licenses are implied and National reserves the right at any time without notice to change said circuitry and specifications.