

THREE-TERMINAL LOW POWER VOLTAGE REGULATORS

DESCRIPTION

The UTC UT71XX series is a set of three-Terminal low power voltage regulators implemented in CMOS technology . They are available with several fixed output voltages ranging from 1.5V~7.0V. The advantage of CMOS technology is low voltage dropout and low quiescent current.

Although designed primarily as fixed voltage regulators, these devices can be used with external components to obtain variable voltages and currents.

FEATURES

- * Low power consumption
- *Low voltage dropout
- *Low temperature coefficient
- *Wide operating voltage (24V Max.)

APPLICATIONS

- *Battery-powered equipment
- *Communication equipment
- *Audio/Video equipment

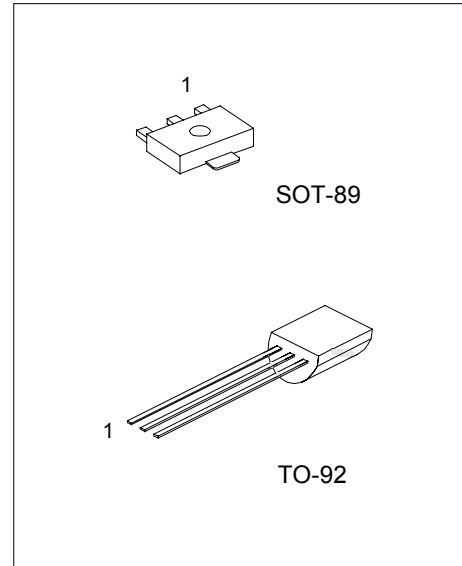

TO-92 : UT71XX-B : 1: VOUT 2: GND 3: VIN
 TO-92 : UT71XX-C : 1: GND 2:VIN 3:VOUT
 SOT-89 : 1: GND 2:VIN 3:VOUT

PAD ASSIGNMENT

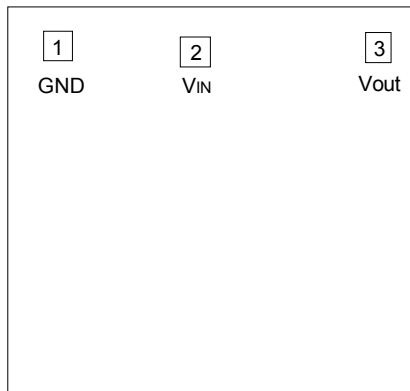

(0,0)

Chip size: 1.34 × 1.30 mm²

*The IC substrate should be connected to VDD in the PCB layout artwork.

PAD NO.	X	Y
1	184	1137
2	615	1121
3	1194	1132

Unit: μ m

BLOCK DIAGRAM

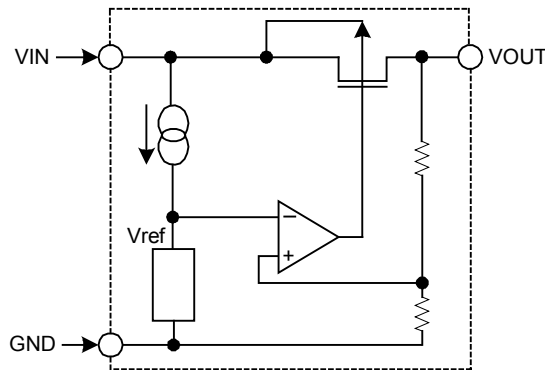

ABSOLUTE MAXIMUM RATINGS

PARAMETER	SYMBOL	RATINGS	UNIT
Supply Voltage	Vcc	-0.3 ~ +28	V
Power Dissipation	Pd	200	mW
Storage Temperature	Tstg	-50 ~ +125	°C
Operating Temperature	Topr	0 ~ +70	°C

UTC UT7118 (+1.8V output type) ELECTRICAL CHARACTERISTICS (Ta=25°C)

PARAMETER	SYMBOL	TEST CONDITIONS	MIN	TYP	MAX	UNIT
Output Voltage	VOUT	VIN=3.8V, IOUT=10mA ±2.4% ±5%	1.757 1.71	1.8 1.8	1.843 1.89	V
Output Current	IOUT	VIN=3.8V	20	30		mA
Load Regulation	ΔVOUT	VIN=3.8V, 1mA ≤ IOUT ≤ 20mA		60	100	mV
Voltage Dropout	Vd	IOUT=1mA		100		mV
Current Consumption	ISS	VIN=3.8V, No load		4	6.0	μA
Line Regulation	$\frac{\Delta V_{OUT}}{\Delta V_{IN} \cdot V_{OUT}}$	2.8V ≤ VIN ≤ 24V, IOUT=0.5mA		0.2		%/V
Input Voltage	VIN				24	V
Temperature Coefficient	$\frac{\Delta V_{OUT}}{\Delta T_a}$	VIN=3.8V, IOUT=10mA 0°C < Ta < 70°C		±0.25		mV/°C

UTC UT7120 (+2.0V output type) ELECTRICAL CHARACTERISTICS (Ta=25°C)

PARAMETER	SYMBOL	TEST CONDITIONS	MIN	TYP	MAX	UNIT
Output Voltage	V _{OUT}	V _{IN} =4V, I _{OUT} =10mA ±2.4% ±5%	1.952 1.9	2.0 2.0	2.048 2.1	V
Output Current	I _{OUT}	V _{IN} =4V	20	30		mA
Load Regulation	ΔV _{OUT}	V _{IN} =4V, 1mA ≤ I _{OUT} ≤ 20mA		60	100	mV
Voltage Dropout	V _d	I _{OUT} =1mA		100		mV
Current Consumption	I _{SS}	V _{IN} =4V, No load		4	6.0	μA
Line Regulation	$\frac{\Delta V_{OUT}}{\Delta V_{IN} \cdot V_{OUT}}$	3V ≤ V _{IN} ≤ 24V, I _{OUT} =0.5mA		0.2		%/V
Input Voltage	V _{IN}				24	V
Temperature Coefficient	$\frac{\Delta V_{OUT}}{\Delta T_a}$	V _{IN} =4V, I _{OUT} =10mA 0°C < T _a < 70°C		±0.3		mV/°C

UTC UT7125 (+2.5V output type) ELECTRICAL CHARACTERISTICS (Ta=25°C)

PARAMETER	SYMBOL	TEST CONDITIONS	MIN	TYP	MAX	UNIT
Output Voltage	V _{OUT}	V _{IN} =4.5V, I _{OUT} =10mA ±2.4% ±5%	2.440 2.375	2.5 2.5	2.560 2.625	V
Output Current	I _{OUT}	V _{IN} =4.5V	20	30		mA
Load Regulation	ΔV _{OUT}	V _{IN} =4.5V, 1mA ≤ I _{OUT} ≤ 20mA		60	100	mV
Voltage Dropout	V _d	I _{OUT} =1mA		100		mV
Current Consumption	I _{SS}	V _{IN} =4.5V, No load		4	6.0	μA
Line Regulation	$\frac{\Delta V_{OUT}}{\Delta V_{IN} \cdot V_{OUT}}$	3.5V ≤ V _{IN} ≤ 24V, I _{OUT} =0.5mA		0.2		%/V
Input Voltage	V _{IN}				24	V
Temperature Coefficient	$\frac{\Delta V_{OUT}}{\Delta T_a}$	V _{IN} =4.5V, I _{OUT} =10mA 0°C < T _a < 70°C		±0.35		mV/°C

UTC UT7127 (+2.7V output type) ELECTRICAL CHARACTERISTICS (Ta=25°C)

PARAMETER	SYMBOL	TEST CONDITIONS	MIN	TYP	MAX	UNIT
Output Voltage	V _{OUT}	V _{IN} =4.7V, I _{OUT} =10mA ±2.4% ±5%	2.635 2.565	2.7 2.7	2.765 2.835	V
Output Current	I _{OUT}	V _{IN} =4.7V	20	30		mA
Load Regulation	ΔV _{OUT}	V _{IN} =4.7V, 1mA ≤ I _{OUT} ≤ 20mA		60	100	mV
Voltage Dropout	V _d	I _{OUT} =1mA		100		mV
Current Consumption	I _{SS}	V _{IN} =4.7V, No load		4	6.0	μA
Line Regulation	$\frac{\Delta V_{OUT}}{\Delta V_{IN} \cdot V_{OUT}}$	3.7V ≤ V _{IN} ≤ 24V, I _{OUT} =0.5mA		0.2		%/V
Input Voltage	V _{IN}				24	V
Temperature Coefficient	$\frac{\Delta V_{OUT}}{\Delta T_a}$	V _{IN} =4.7V, I _{OUT} =10mA 0°C < T _a < 70°C		±0.4		mV/°C

UTC UT7128 (+2.8V output type) ELECTRICAL CHARACTERISTICS (Ta=25°C)

PARAMETER	SYMBOL	TEST CONDITIONS	MIN	TYP	MAX	UNIT
Output Voltage	V _{OUT}	V _{IN} =4.8V, I _{OUT} =10mA ±2.4%±5%	2.732 2.660	2.8 2.8	2.867 2.940	V
Output Current	I _{OUT}	V _{IN} =4.8V	20	30	-	mA
Load Regulation	ΔV _{OUT}	V _{IN} =4.8V, 1mA ≤ I _{OUT} ≤ 20mA		60	100	mV
Voltage Dropout	V _d	I _{OUT} =1mA		100		mV
Current Consumption	I _{SS}	V _{IN} =4.8V, No load		4	6.0	μA
Line Regulation	$\frac{\Delta V_{OUT}}{\Delta V_{IN} \cdot V_{OUT}}$	3.8V ≤ V _{IN} ≤ 24V, I _{OUT} =1mA		0.2		%/V
Input Voltage	V _{IN}				24	V
Temperature Coefficient	$\frac{\Delta V_{OUT}}{\Delta T_a}$	V _{IN} =4.8V, I _{OUT} =10mA 0°C < T _a < 70°C		±0.4		mV/°C

UTC UT7130 (+3.0V output type) ELECTRICAL CHARACTERISTICS (Ta=25°C)

PARAMETER	SYMBOL	TEST CONDITIONS	MIN	TYP	MAX	UNIT
Output Voltage	V _{OUT}	V _{IN} =5V, I _{OUT} =10mA ±2.4%±5%	2.928 2.850	3.0 3.0	3.072 3.150	V
Output Current	I _{OUT}	V _{IN} =5V	20	30	-	mA
Load Regulation	ΔV _{OUT}	V _{IN} =5V, 1mA ≤ I _{OUT} ≤ 20mA		60	100	mV
Voltage Dropout	V _d	I _{OUT} =1mA		100		mV
Current Consumption	I _{SS}	V _{IN} =5V, No load		4	6.0	μA
Line Regulation	$\frac{\Delta V_{OUT}}{\Delta V_{IN} \cdot V_{OUT}}$	4V ≤ V _{IN} ≤ 24V, I _{OUT} =1mA		0.2		%/V
Input Voltage	V _{IN}				24	V
Temperature Coefficient	$\frac{\Delta V_{OUT}}{\Delta T_a}$	V _{IN} =5V, I _{OUT} =10mA 0°C < T _a < 70°C		±0.45		mV/°C

UTC UT7133 (+3.3V output type) ELECTRICAL CHARACTERISTICS (Ta=25°C)

PARAMETER	SYMBOL	TEST CONDITIONS	MIN	TYP	MAX	UNIT
Output Voltage	V _{OUT}	V _{IN} =5.5V, I _{OUT} =10mA ±2.4%±5%	3.220 3.135	3.3 3.3	3.379 3.465	V
Output Current	I _{OUT}	V _{IN} =5.5V	20	30		mA
Load Regulation	ΔV _{OUT}	V _{IN} =5.5V, 1mA ≤ I _{OUT} ≤ 30mA		60	100	mV
Voltage Dropout	V _d	I _{OUT} =1mA		100		mV
Current Consumption	I _{SS}	V _{IN} =5.5V, No load		4	6.0	μA
Line Regulation	$\frac{\Delta V_{OUT}}{\Delta V_{IN} \cdot V_{OUT}}$	4.5V ≤ V _{IN} ≤ 24V, I _{OUT} =1mA		0.2		%/V
Input Voltage	V _{IN}				24	V
Temperature Coefficient	$\frac{\Delta V_{OUT}}{\Delta T_a}$	V _{IN} =5.5V, I _{OUT} =10mA 0°C < T _a < 70°C		±0.5		mV/°C

UTC UT7136 (+3.6V output type) ELECTRICAL CHARACTERISTICS (Ta=25°C)

PARAMETER	SYMBOL	TEST CONDITIONS	MIN	TYP	MAX	UNIT
Output Voltage	V _{OUT}	V _{IN} =5.6V, I _{OUT} =10mA ±2.4%±5%	3.513 3.420	3.6 3.6	3.686 3.780	V
Output Current	I _{OUT}	V _{IN} =5.6V	20	30		mA
Load Regulation	ΔV _{OUT}	V _{IN} =5.6V, 1mA ≤ I _{OUT} ≤ 30mA		60	100	mV
Voltage Dropout	V _d	I _{OUT} =1mA		100		mV
Current Consumption	I _{SS}	V _{IN} =5.6V, No load		4	7.0	μA
Line Regulation	$\frac{\Delta V_{OUT}}{\Delta V_{IN} \cdot V_{OUT}}$	4.6V ≤ V _{IN} ≤ 24V, I _{OUT} =1mA		0.2		%/V
Input Voltage	V _{IN}				24	V
Temperature Coefficient	$\frac{\Delta V_{OUT}}{\Delta T_a}$	V _{IN} =5.6V, I _{OUT} =10mA 0°C < T _a < 70°C		±0.6		mV/°C

UTC UT7144 (+4.4V output type) ELECTRICAL CHARACTERISTICS (Ta=25°C)

PARAMETER	SYMBOL	TEST CONDITIONS	MIN	TYP	MAX	UNIT
Output Voltage	V _{OUT}	V _{IN} =6.4V, I _{OUT} =10mA ±2.4%±5%	4.294 4.180	4.4 4.4	4.505 4.620	V
Output Current	I _{OUT}	V _{IN} =6.4V	20	30		mA
Load Regulation	ΔV _{OUT}	V _{IN} =6.4V, 1mA ≤ I _{OUT} ≤ 30mA		60	100	mV
Voltage Dropout	V _d	I _{OUT} =1mA		100		mV
Current Consumption	I _{SS}	V _{IN} =6.4V, No load		4	7.5	μA
Line Regulation	$\frac{\Delta V_{OUT}}{\Delta V_{IN} \cdot V_{OUT}}$	5.4V ≤ V _{IN} ≤ 24V, I _{OUT} =1mA		0.2		%/V
Input Voltage	V _{IN}				24	V
Temperature Coefficient	$\frac{\Delta V_{OUT}}{\Delta T_a}$	V _{IN} =6.4V, I _{OUT} =10mA 0°C < T _a < 70°C		±0.7		mV/°C

UTC UT7150 (+5.0V output type) ELECTRICAL CHARACTERISTICS (Ta=25°C)

PARAMETER	SYMBOL	TEST CONDITIONS	MIN	TYP	MAX	UNIT
Output Voltage	V _{OUT}	V _{IN} =7V, I _{OUT} =10mA ±2.4%±5%	4.88 4.75	5.0 5.0	5.12 5.25	V
Output Current	I _{OUT}	V _{IN} =7V	20	30		mA
Load Regulation	ΔV _{OUT}	V _{IN} =7V, 1mA ≤ I _{OUT} ≤ 30mA		60	100	mV
Voltage Dropout	V _d	I _{OUT} =1mA		100		mV
Current Consumption	I _{SS}	V _{IN} =7V, No load		5	9.0	μA
Line Regulation	$\frac{\Delta V_{OUT}}{\Delta V_{IN} \cdot V_{OUT}}$	6V ≤ V _{IN} ≤ 24V, I _{OUT} =1mA		0.2		%/V
Input Voltage	V _{IN}				24	V
Temperature Coefficient	$\frac{\Delta V_{OUT}}{\Delta T_a}$	V _{IN} =7V, I _{OUT} =10mA 0°C < T _a < 70°C		±0.75		mV/°C

UTC UT7170 (+7.0V output type) ELECTRICAL CHARACTERISTICS (Ta=25°C)

PARAMETER	SYMBOL	TEST CONDITIONS	MIN	TYP	MAX	UNIT
Output Voltage	V_{OUT}	$V_{IN}=9V, I_{OUT}=10mA$ $\pm 2.4\% \pm 5\%$	6.832 6.65	7.0 7.0	7.168 7.35	V
Output Current	I_{OUT}	$V_{IN}=9V$	20	30		mA
Load Regulation	ΔV_{OUT}	$V_{IN}=9V, 1mA \leq I_{OUT} \leq 30mA$		60	100	mV
Voltage Dropout	V_d	$I_{OUT}=1mA$		100		mV
Current Consumption	I_{SS}	$V_{IN}=9V, \text{No load}$		5	12.5	μA
Line Regulation	$\frac{\Delta V_{OUT}}{\Delta V_{IN} \cdot V_{OUT}}$	$8V \leq V_{IN} \leq 24V, I_{OUT}=1mA$		0.2		%/V
Input Voltage	V_{IN}				24	V
Temperature Coefficient	$\frac{\Delta V_{OUT}}{\Delta T_a}$	$V_{IN}=9V, I_{OUT}=10mA$ $0^\circ C < T_a < 70^\circ C$		± 1.05		mV/°C

APPLICATION CIRCUIT

The basic circuits using the UT71XX series

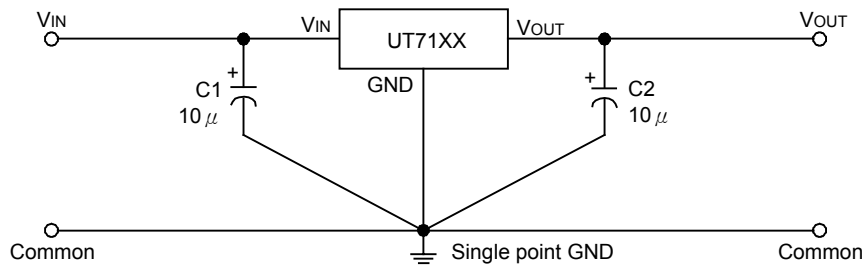

High output current positive voltage regulator

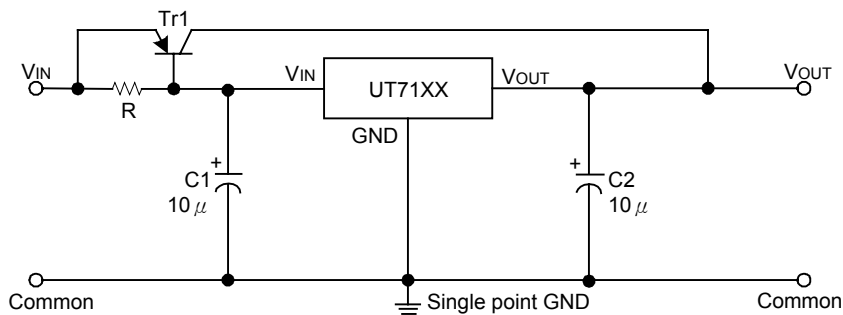

Short-circuit protection for Tr1

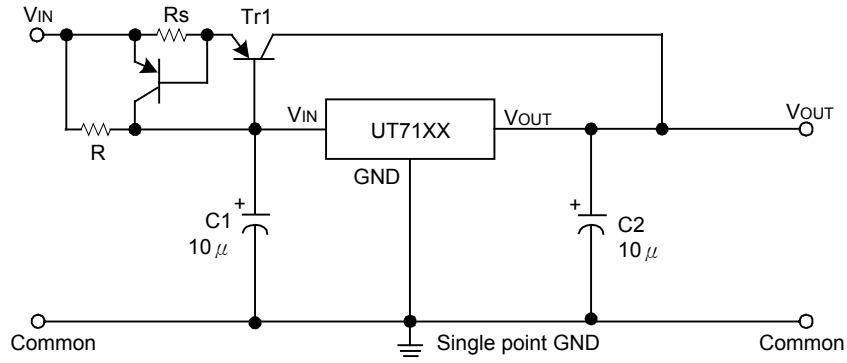

Circuit for increasing output voltage

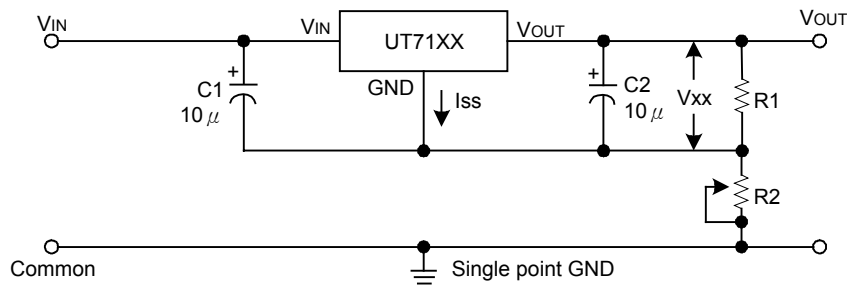

$$V_{OUT} = V_{xx} \left(1 + \frac{R_2}{R_1} \right) + I_{ss} R_2$$

$$\approx V_{xx} \left(1 + \frac{R_2}{R_1} \right)$$

Circuit for increasing output voltage

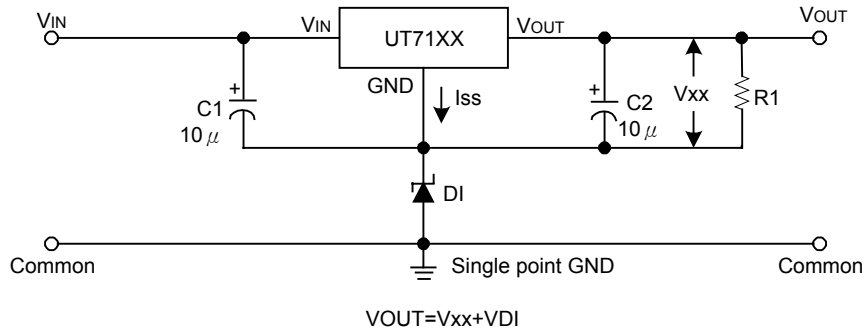

Constant current regulator

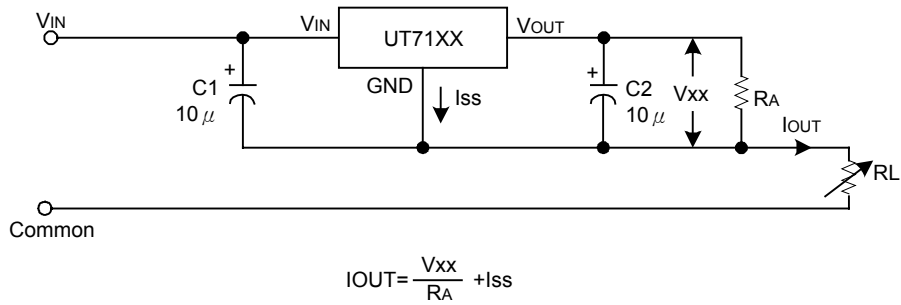

Dual supply

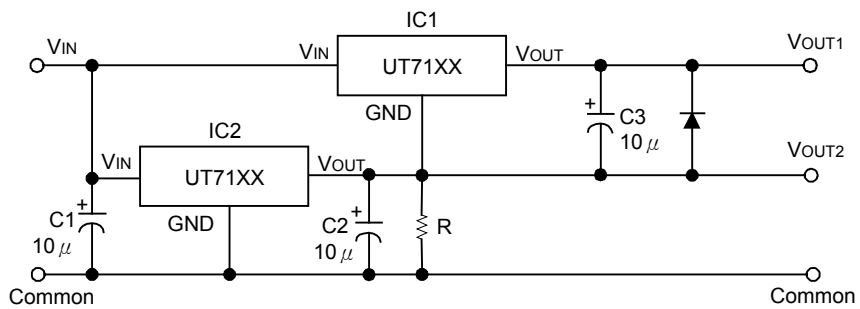

UTC assumes no responsibility for equipment failures that result from using products at values that exceed, even momentarily, rated values (such as maximum ratings, operating condition ranges, or other parameters) listed in products specifications of any and all UTC products described or contained herein. UTC products are not designed for use in life support appliances, devices or systems where malfunction of these products can be reasonably expected to result in personal injury. Reproduction in whole or in part is prohibited without the prior written consent of the copyright owner. The information presented in this document does not form part of any quotation or contract, is believed to be accurate and reliable and may be changed without notice.