

TOSHIBA CMOS DIGITAL INTEGRATED CIRCUIT SILICON MONOLITHIC

**TC74HC157AP, TC74HC157AF, TC74HC157AFN  
TC74HC158AP, TC74HC158AF, TC74HC158AFN**

**TC74HC157AP/AF/AFN QUAD 2 - CHANNEL MULTIPLEXER  
TC74HC158AP/AF/AFN QUAD 2 - CHANNEL MULTIPLEXER  
(INVERTING)**

(Note) The JEDEC SOP (FN) is not available in Japan.

The TC74HC157A and TC74HC158A are high speed CMOS 2 - CHANNEL MULTIPLEXERS fabricated with silicon gate C<sup>2</sup>MOS technology.

They achieve the high speed operation similar to equivalent LSTTL while maintaining the CMOS low power dissipation.

The TC74HC158A is an inverting multiplexer while the TC74HC157A is a non-inverting.

When  $\overline{STROBE}$  is held high, selection of data is inhibited and all the outputs become low in the case of HC157A or high in the case of HC158A.

The SELECT decoding determines whether the A or B inputs get transferred to their corresponding Y ( $\overline{Y}$ ) outputs.

All inputs are equipped with protection circuits against static discharge or transient excess voltage.

**FEATURES :**

- High Speed..... $t_{pd} = 10ns$ (typ.) at  $V_{CC} = 5V$
- Low Power Dissipation..... $I_{CC} = 4\mu A$ (Max.) at  $T_a = 25^\circ C$
- High Noise Immunity..... $V_{NIH} = V_{NIL} = 28\% V_{CC}$  (Min.)
- Output Drive Capability..... 10 LSTTL Loads
- Symmetrical Output Impedance...  $|I_{OH}| = I_{OL} = 4mA$ (Min.)
- Balanced Propagation Delays.....  $t_{pLH} \approx t_{pHL}$
- Wide Operating Voltage Range...  $V_{CC}$  (opr.) = 2V ~ 6V
- Pin and Function Compatible with 74LS157/158

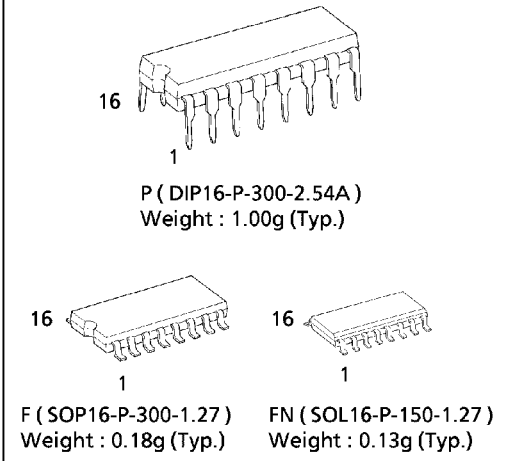

**PIN ASSIGNMENT**

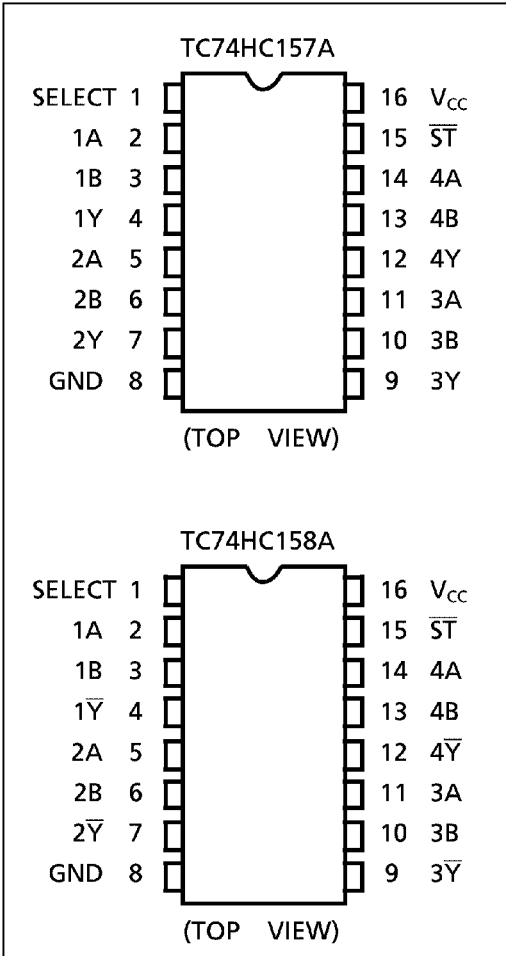

**TRUTH TABLE**

INPUTS				OUTPUTS	
$\overline{ST}$	SELECT	A	B	Y (157A)	$\overline{Y}$ (158A)
H	X	X	X	L	H
L	L	L	X	L	H
L	L	H	X	H	L
L	H	X	L	L	H
L	H	X	H	H	L

X : Don't Care

961001EBA2

● TOSHIBA is continually working to improve the quality and the reliability of its products. Nevertheless, semiconductor devices in general can malfunction or fail due to their inherent electrical sensitivity and vulnerability to physical stress. It is the responsibility of the buyer, when utilizing TOSHIBA products, to observe standards of safety, and to avoid situations in which a malfunction or failure of a TOSHIBA product could cause loss of human life, bodily injury or damage to property. In developing your designs, please ensure that TOSHIBA products are used within specified operating ranges as set forth in the most recent products specifications. Also, please keep in mind the precautions and conditions set forth in the TOSHIBA Semiconductor Reliability Handbook.

IEC LOGIC SYMBOL

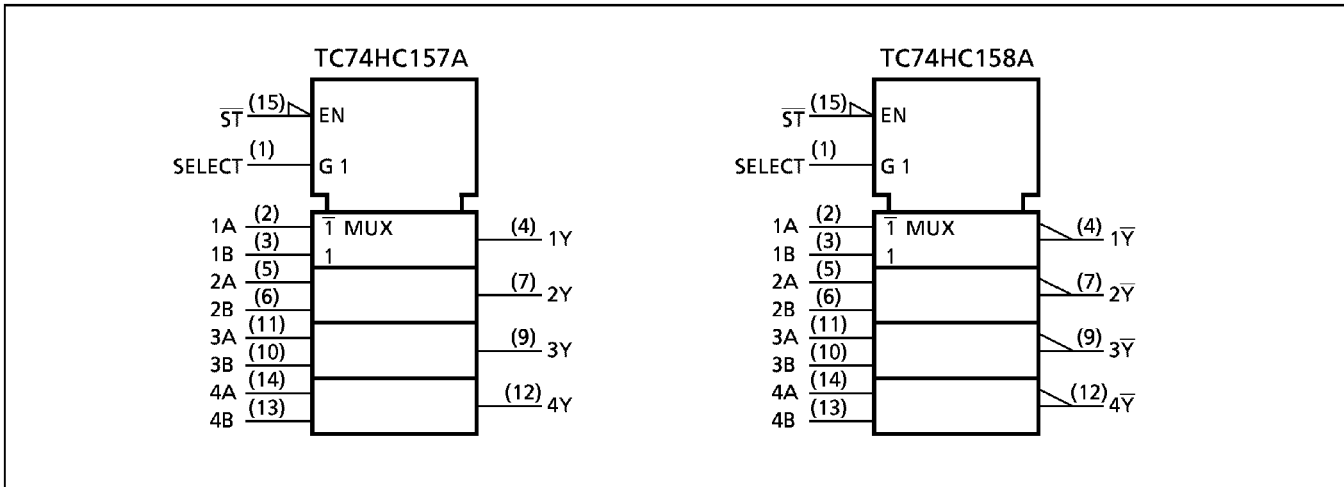

961001EBA2'

- The products described in this document are subject to foreign exchange and foreign trade control laws.
- The information contained herein is presented only as a guide for the applications of our products. No responsibility is assumed by TOSHIBA CORPORATION for any infringements of intellectual property or other rights of the third parties which may result from its use. No license is granted by implication or otherwise under any intellectual property or other rights of TOSHIBA CORPORATION or others.
- The information contained herein is subject to change without notice.

## ABSOLUTE MAXIMUM RATINGS

PARAMETER	SYMBOL	VALUE	UNIT
Supply Voltage Range	$V_{CC}$	-0.5~7	V
DC Input Voltage	$V_{IN}$	-0.5~ $V_{CC} + 0.5$	V
DC Output Voltage	$V_{OUT}$	-0.5~ $V_{CC} + 0.5$	V
Input Diode Current	$I_{IK}$	$\pm 20$	mA
Output Diode Current	$I_{OK}$	$\pm 20$	mA
DC Output Current	$I_{OUT}$	$\pm 25$	mA
DC $V_{CC}$ / Ground Current	$I_{CC}$	$\pm 50$	mA
Power Dissipation	$P_D$	500 (DIP)* / 180 (SOP)	mW
Storage Temperature	$T_{stg}$	-65~150	°C

\*500mW in the range of  $T_a = -40^{\circ}\text{C} \sim 65^{\circ}\text{C}$ . From  $T_a = 65^{\circ}\text{C}$  to  $85^{\circ}\text{C}$  a derating factor of  $-10\text{mW}/^{\circ}\text{C}$  shall be applied until 300mW.

## RECOMMENDED OPERATING CONDITIONS

PARAMETER	SYMBOL	VALUE	UNIT
Supply Voltage	$V_{CC}$	2~6	V
Input Voltage	$V_{IN}$	0~ $V_{CC}$	V
Output Voltage	$V_{OUT}$	0~ $V_{CC}$	V
Operating Temperature	$T_{opr}$	-40~85	°C
Input Rise and Fall Time	$t_r, t_f$	0~1000 ( $V_{CC} = 2.0\text{V}$ ) 0~500 ( $V_{CC} = 4.5\text{V}$ ) 0~400 ( $V_{CC} = 6.0\text{V}$ )	ns

## DC ELECTRICAL CHARACTERISTICS

PARAMETER	SYMBOL	TEST CONDITION	$V_{CC}$ (V)	$T_a = 25^{\circ}\text{C}$			$T_a = -40 \sim 85^{\circ}\text{C}$		UNIT	
				MIN.	TYP.	MAX.	MIN.	MAX.		
High - Level Input Voltage	$V_{IH}$		2.0	1.50	—	—	1.50	—	V	
			4.5	3.15	—	—	3.15	—		
			6.0	4.20	—	—	4.20	—		
Low - Level Input Voltage	$V_{IL}$		2.0	—	—	0.50	—	0.50	V	
			4.5	—	—	1.35	—	1.35		
			6.0	—	—	1.80	—	1.80		
High - Level Output Voltage	$V_{OH}$	$V_{IN} = V_{IH}$ or $V_{IL}$	$I_{OH} = -20\mu\text{A}$	2.0	1.9	2.0	—	1.9	—	V
				4.5	4.4	4.5	—	4.4	—	
				6.0	5.9	6.0	—	5.9	—	
Low - Level Output Voltage	$V_{OL}$	$V_{IN} = V_{IH}$ or $V_{IL}$	$I_{OL} = 20\mu\text{A}$	2.0	—	0.0	0.1	—	0.1	V
				4.5	—	0.0	0.1	—	0.1	
				6.0	—	0.0	0.1	—	0.1	
High - Level Output Voltage	$V_{OH}$	$V_{IN} = V_{IH}$ or $V_{IL}$	$I_{OH} = -4\text{ mA}$ $I_{OH} = -5.2\text{ mA}$	4.5	4.18	4.31	—	4.13	—	V
				6.0	5.68	5.80	—	5.63	—	
				4.5	—	0.17	0.26	—	0.33	
6.0	—	0.18	0.26	—	0.33					
Input Leakage Current	$I_{IN}$	$V_{IN} = V_{CC}$ or GND	6.0	—	—	$\pm 0.1$	—	$\pm 1.0$	$\mu\text{A}$	
Quiescent Supply Current	$I_{CC}$	$V_{IN} = V_{CC}$ or GND	6.0	—	—	4.0	—	40.0		

AC ELECTRICAL CHARACTERISTICS (  $C_L = 15\text{pF}$ ,  $V_{CC} = 5\text{V}$ ,  $T_a = 25^\circ\text{C}$ , Input  $t_r = t_f = 6\text{ns}$  )

PARAMETER	SYMBOL	TEST CONDITION	MIN.	TYP.	MAX.	UNIT
Output Transition Time	$t_{TLH}$ $t_{THL}$		—	4	8	ns
Propagation Delay Time (A, B—Y, $\bar{Y}$ )	$t_{pLH}$ $t_{pHL}$		—	10	16	
Propagation Delay Time (SELECT—Y, $\bar{Y}$ )	$t_{pLH}$ $t_{pHL}$		—	13	21	
Propagation Delay Time (STOROB $\bar{E}$ —Y, $\bar{Y}$ )	$t_{pLH}$ $t_{pHL}$		—	10	19	

AC ELECTRICAL CHARACTERISTICS (  $C_L = 50\text{pF}$ , Input  $t_r = t_f = 6\text{ns}$  )

PARAMETER	SYMBOL	TEST CONDITION	$T_a = 25^\circ\text{C}$			$T_a = -40\text{--}85^\circ\text{C}$		UNIT	
			$V_{CC}$ (V)	MIN.	TYP.	MAX.	MIN.		MAX.
Output Transition Time	$t_{TLH}$ $t_{THL}$		2.0	—	30	75	—	95	ns
			4.5	—	8	15	—	19	
			6.0	—	7	13	—	16	
Propagation Delay Time (A, B—Y, $\bar{Y}$ )	$t_{pLH}$ $t_{pHL}$		2.0	—	36	100	—	125	
			4.5	—	12	20	—	25	
			6.0	—	10	17	—	21	
Propagation Delay Time (SELECT—Y, $\bar{Y}$ )	$t_{pLH}$ $t_{pHL}$		2.0	—	50	125	—	155	
			4.5	—	16	25	—	31	
			6.0	—	14	21	—	26	
Propagation Delay Time (STOROB $\bar{E}$ —Y, $\bar{Y}$ )	$t_{pLH}$ $t_{pHL}$		2.0	—	36	115	—	145	
			4.5	—	12	23	—	29	
			6.0	—	10	20	—	25	
Input Capacitance	$C_{IN}$		—	5	10	—	10	pF	
Power Dissipation Capacitance	$C_{PD}$ (1)	TC74HC157A	—	57	—	—	—		
		TC74HC158A	—	53	—	—	—		

Note (1)  $C_{PD}$  is defined as the value of the internal equivalent capacitance which is calculated from the operating current consumption without load.

Average operating current can be obtained by the equation :

$$I_{CC}(\text{opr}) = C_{PD} \cdot V_{CC} \cdot f_{IN} + I_{CC}/4 \text{ (per bit)}$$

**DIP 16PIN OUTLINE DRAWING (DIP16-P-300-2.54A)**

Unit in mm

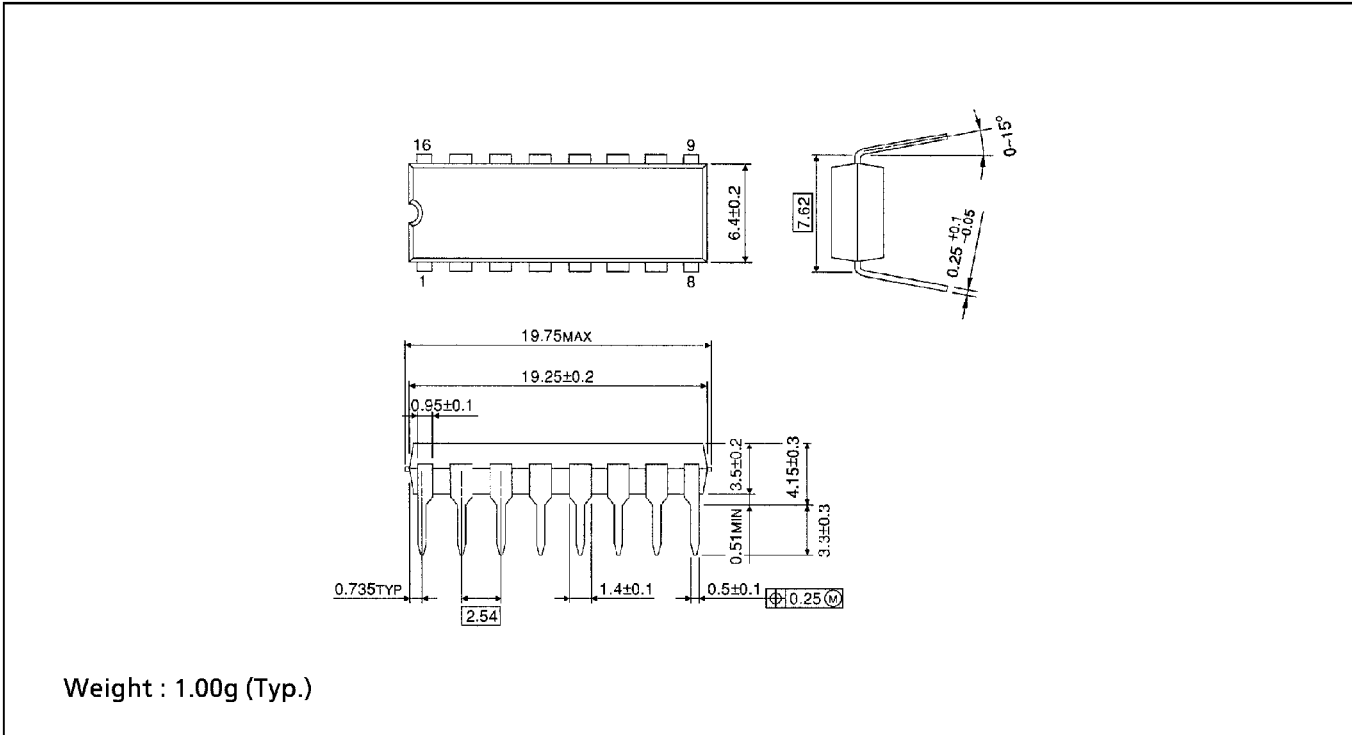

**SOP 16PIN (200mil BODY) OUTLINE DRAWING (SOP16-P-300-1.27)**

Unit in mm

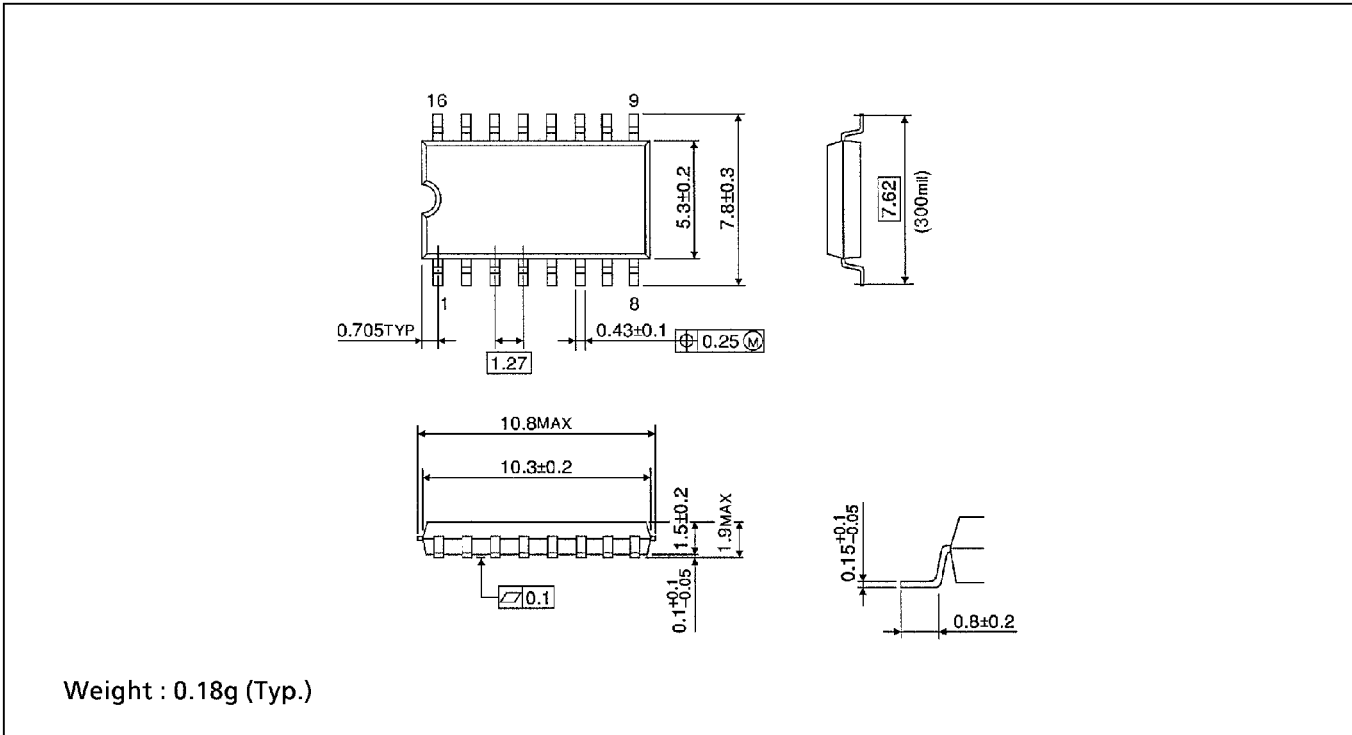

**SOP 16PIN (150mil BODY) OUTLINE DRAWING (SOL14-P-150 -1.27)**

Unit in mm

(Note) This package is not available in Japan.

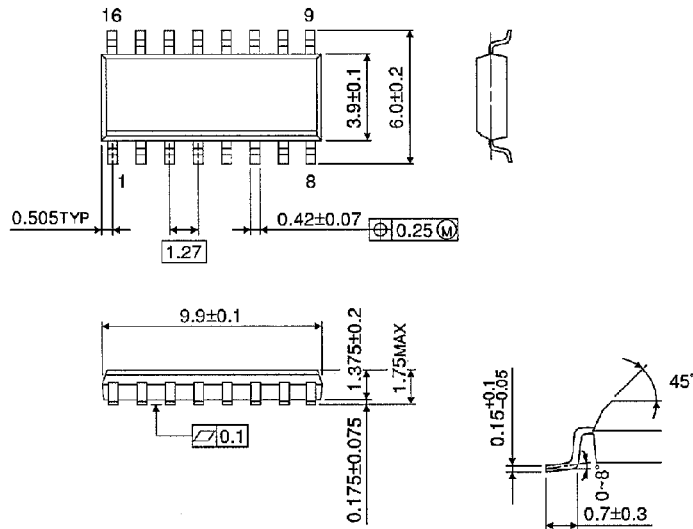

Weight : 0.13g (Typ.)