

NPN METAL CAN – SWITCHING AND GENERAL PURPOSE (Cont'd.)

TYPE NO.	V _{CB}	V _{CE}	V _{EB}	h _{FE}	at	I _C	V _{CE}	V _{CE(s)} at I _B	I _C	f _T	C _{ob}	I _{CBO} at V _{CB}	CASE		
	V	V	V	min	max	mA	V	V	mA	mA	MHz	pF		μA	V
2N3302	60	30	5	100	300	150	10	.22	15	150	250	8	.01	50	TO-18
2N3326	60	40	5	40	120	150	10	.4	15	150	250	8	.1	50	TO-5
2N3388	125	100	6	60	—	—	5	1.0	.05	2.5	36	35	—	—	TO-5
2N3418	80	60	8	20	60	1	2	.25	.100	1	40	130	50	80	TO-5
2N3419	125	80	8	20	60	1	2	.25	.100	1	40	130	50	120	TO-5
2N3420	85	60	8	40	120	1	2	.25	.100	1	40	130	50	80	TO-5
2N3421	125	80	8	40	120	1	2	.25	.100	1	40	130	50	120	TO-5
2N3498	100	100	6	40	120	.150	10	.6	30	300	150	80	.05	100	TO-5
2N3499	100	100	6	100	300	.150	10	.6	30	300	150	80	.05	100	TO-5
2N3500	150	150	6	40	120	.150	10	.4	15	150	150	80	.05	150	TO-5
2N3501	150	150	6	100	300	.150	10	.4	15	150	150	80	.05	150	TO-5
2N3665	120	80	10	40	120	150	10	.5	15	150	60	12	.05	60	TO-5
2N3666	120	80	10	100	300	150	10	.5	15	150	60	12	.05	60	TO-5
2N3678	75	55	6	40	120	150	10	.4	15	150	250	8	.01	60	TO-5
2N3700	140	80	7	100	300	150	10	.2	15	150	100	12	.01	90	TO-18
2N3701	140	80	7	40	120	150	10	.2	15	150	80	12	.01	90	TO-18
2N3945	70	50	8	40	250	150	10	.5	15	150	60	12	—	—	TO-5
2N3946	60	40	6	20	—	50	1	0.3	5	50	250	4	.01	40	TO-18
2N3947	60	40	6	40	—	50	1	0.3	5	50	300	4	.01	40	TO-18
2N4000	100	80	8	30	120	500	2	.3	50	500	40	60	2	90	TO-5
2N4001	120	100	8	40	120	500	2	.3	50	500	40	60	2	110	TO-5
2N4237	50	40	6	30	150	250	1	.6	100	1000	1	100	100	50	TO-5
2N4238	80	60	6	30	150	250	1	.6	100	1000	1	100	100	80	TO-5
2N4239	100	80	6	30	150	250	1	.6	100	1000	1	100	100	100	TO-5
2N4269	200	140	15	40	200	10	10	1.0	1	10	—	5	1	150	TO-18
2N4270	200	140	15	40	200	10	10	1.0	1	10	—	5	1	150	TO-5
2N4271	175	140	8	20	140	200	10	.8	20	200	20	25	.5	30	TO-5
2N4272	175	140	9	20	140	200	10	.2	667	2000	10	75	.1	50	TO-5
2N4300	100	80	8	30	120	1	2	.3	.100	1	30	—	10	90	TO-5
2N4863	140	120	8	50	150	0.5	5	0.2	0.05	0.5	50	50	0.1	60	TO-5
2N4877	70	60	5	20	100	4	2	1.0	0.4	4	4	100	100	70	TO-5
2N4943	120	80	7	100	300	150	10	0.25	15	150	150	12	.01	60	TO-39
2N4960	60	60	6	100	300	150	10	0.5	50	500	250	15	.01	50	TO-39
2N4961	80	80	6	100	300	150	10	0.5	50	500	250	15	.01	50	TO-39
2N4962	60	60	6	100	300	150	10	0.5	50	500	250	15	.01	50	TO-18
2N4963	80	80	6	100	300	150	10	0.5	50	500	250	15	.01	50	TO-18

NPN METAL CAN – SATURATED SWITCH

TYPE NO.	V _{CB}	V _{CE}	V _{EB}	h _{FE}	at	I _C	V _{CE}	V _{CE(s)} at I _C	I _C	f _T	C _{ob}	t _{on}	t _{off}	I _{CBO} at V _{CB}	CASE	
	V	V	V	min	ma	mA	V	V	mA	MHz	pF	nS	nS	μA		V
2N706	25	20	3	20	—	10	1	0.6	10	400	6	—	—	0.5	15	TO-18
2N706A	25	20	5	20	60	10	1	0.6	10	400	5	40	75	0.5	15	TO-18
2N706B	25	20	5	20	60	10	1	0.4	10	400	5	40	75	0.5	15	TO-18
2N706C	40	15	5	20	60	10	5	0.3	30	200	5	40	75	—	—	TO-18
2N708	40	15	5	30	120	10	1	0.4	10	400	6	40	70	.025	20	TO-18
2N709	15	6	4	20	120	10	0.5	0.3	3	600	3	15	15	0.5	5	TO-18
2N709A	15	6	4	30	90	10	0.5	0.3	3	900	3	15	15	.005	5	TO-18
2N743	20	12	5	20	60	10	1	.35	10	280	5	16	24	1	20	TO-18
2N743A	40	15	5	20	60	10	5	0.6	100	500	4	12	15	—	—	TO-18
2N744	20	12	5	40	120	10	1	.35	10	280	5	16	24	1	20	TO-18
2N744A	40	15	5	40	120	10	5	0.6	100	500	4	12	15	—	—	TO-18
2N753	25	20	5	40	120	10	1	.60	10	200	5	40	75	.05	15	TO-18
2N783	40	15	5	20	60	10	1	.25	10	200	3.5	16	30	.25	25	TO-18
2N784	30	12	5	25	—	10	1	.19	10	200	3.5	20	40	.25	25	TO-18
2N784A	40	15	5	25	150	10	5	0.19	10	300	3.5	20	40	—	—	TO-18
2N834	40	25	5	25	—	10	1	.25	10	350	4	35	75	.50	20	TO-18
2N834A	40	25	5	25	—	10	1	.25	10	500	4	16	24	.50	20	TO-18
2N835	25	20	5	20	—	10	1	.30	10	300	4	20	35	.50	20	TO-18
2N914	40	15	5	30	120	10	1	0.7	0.8	60	6	40	40	.025	20	TO-18
2N947	15	12	3	30	—	10	1	0.4	5	200	8	—	50	—	—	TO-18
2N1252	20	15	5	15	45	150	10	1.5	150	40	45	—	150	—	—	TO-5
2N1253	20	15	5	30	90	150	10	1.5	150	50	45	—	150	—	—	TO-5
2N1708	25	12	3	20	—	10	1	.35	50	200	6	40	75	.025	15	TO-46
2N2205	25	12	3	20	—	10	1	.22	10	200	6	40	75	.025	15	TO-18
2N2206	25	12	3	40	120	10	10	.22	10	200	6	40	75	.025	15	TO-46

CASE OUTLINE DRAWINGS

D



CASE A CBR1 Series
CBR2 Series

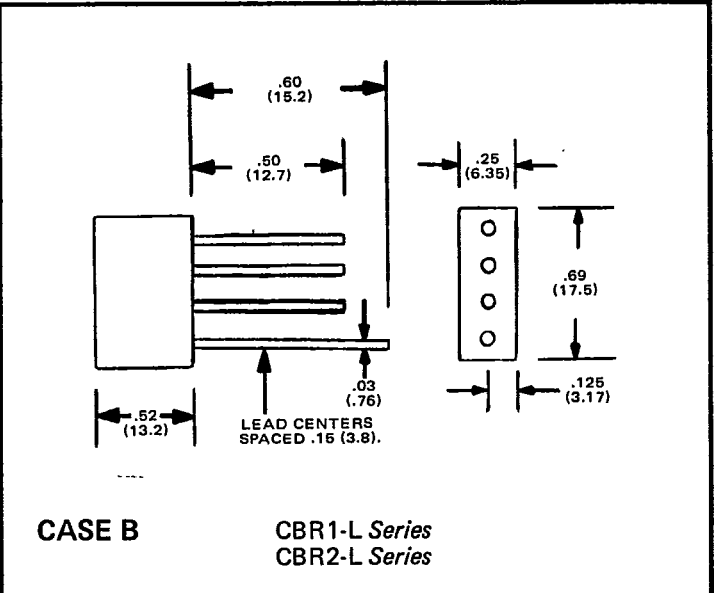

CASE B CBR1-L Series
CBR2-L Series

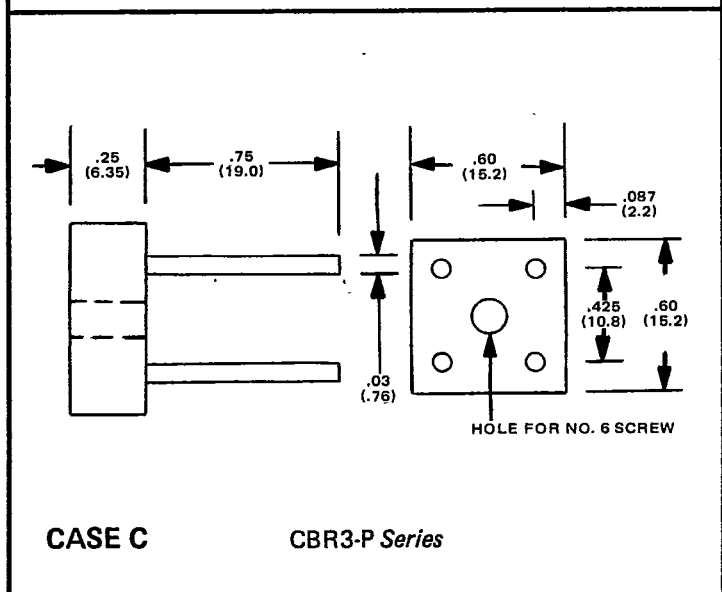

CASE C CBR3-P Series

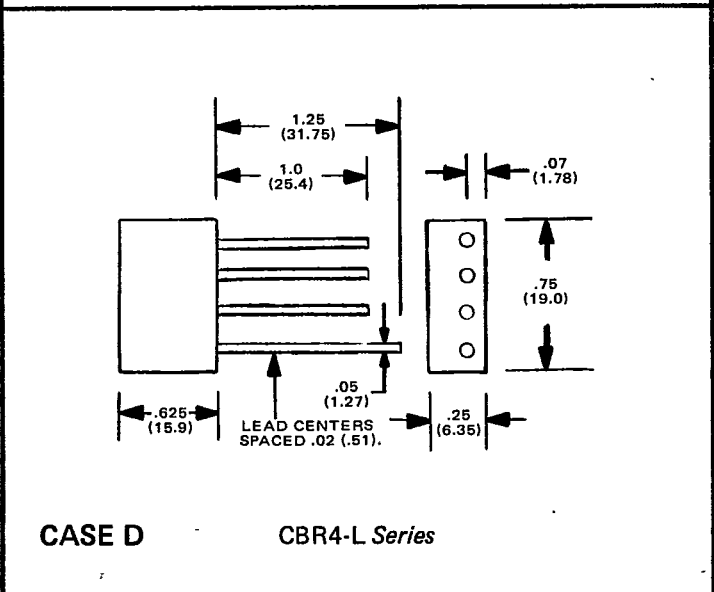

CASE D CBR4-L Series

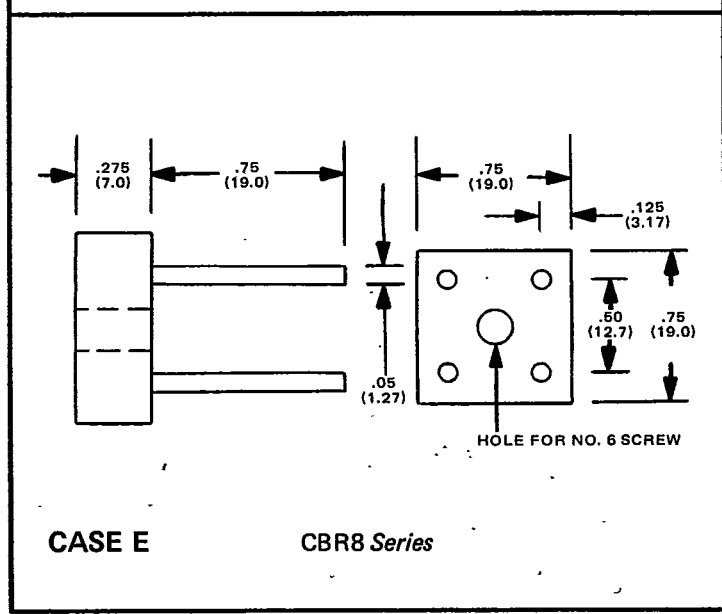

CASE E CBR8 Series

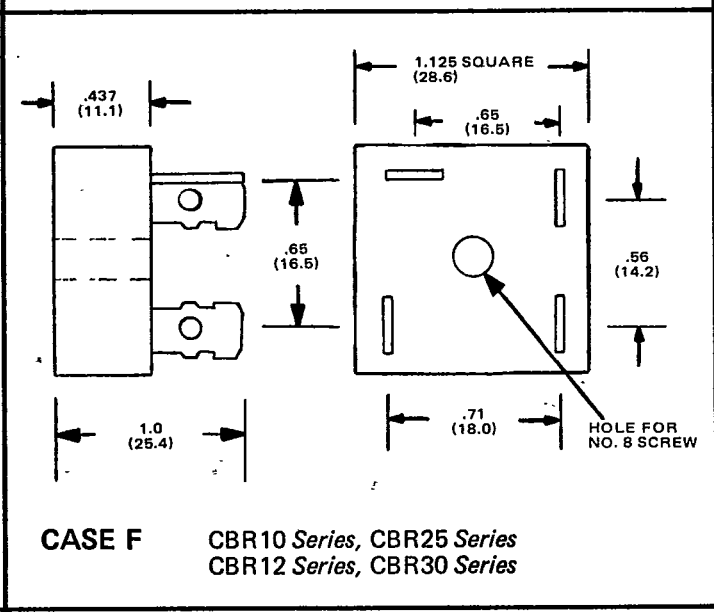

CASE F CBR10 Series, CBR25 Series
CBR12 Series, CBR30 Series

All Dimensions in Inches (Millimeters)
Drawings Not To Scale

f

MECHANICAL OUTLINE DRAWINGS

TO-5

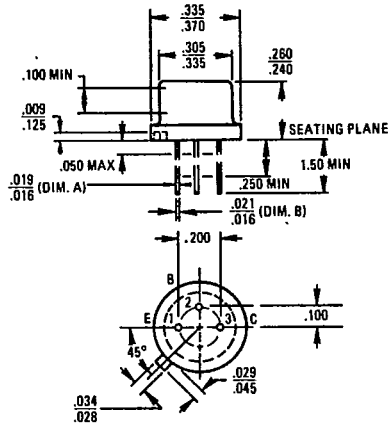

TO-18

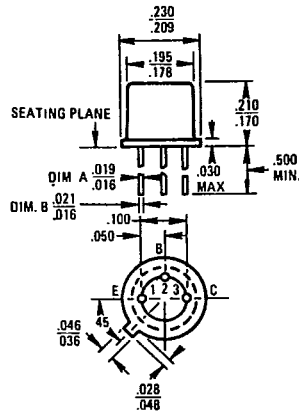

TO-39

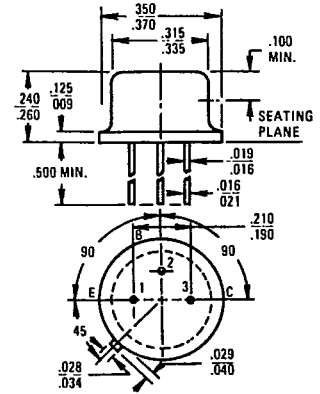

TO-46

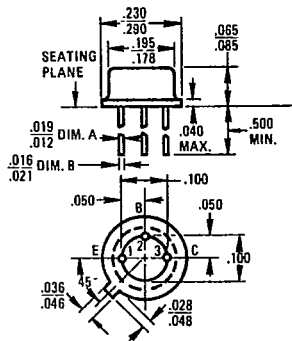

TO-72

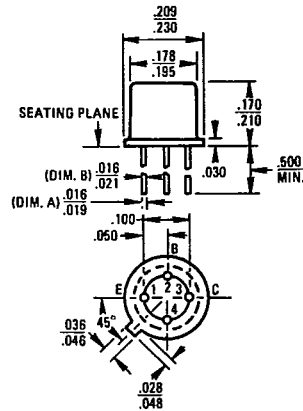

TO-92

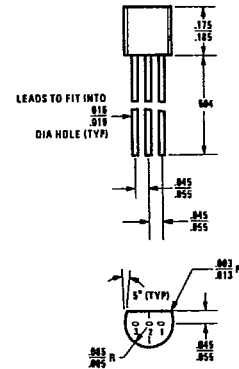

TO-98

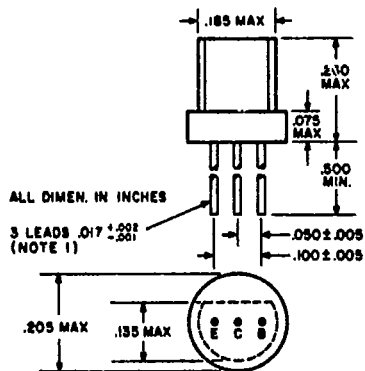

TO-105

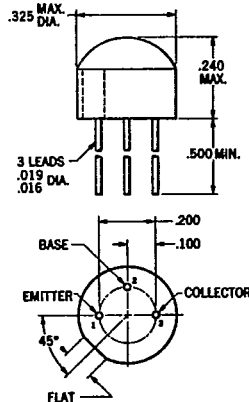

TO-106

