

## DM74AS573 Octal D-Type Transparent Latch with 3-STATE Outputs

### General Description

These 8-bit registers feature totem-pole 3-STATE outputs designed specifically for driving highly-capacitive or relatively low-impedance loads. The high-impedance state and increased high-logic-level drive provide these registers with the capability of being connected directly to and driving the bus lines in a bus-organized system without need for interface or pull-up components. They are particularly attractive for implementing buffer registers, I/O ports, bidirectional bus drivers, and working registers.

The eight latches of the AS573 are transparent D-type latches, meaning that while the enable (G) is high the Q outputs will follow the data (D) inputs. When the enable is taken low the output will be latched at the level of the data that was set up.

A buffered output control input can be used to place the eight outputs in either a normal logic state (high or low logic levels) or a high-impedance state. In the high-impedance state the outputs neither load nor drive the bus lines significantly.

The output control does not affect the internal operation of the latches. That is, the old data can be retained or new data can be entered even while the outputs are off.

The pin-out is arranged to ease printed circuit board layout. All data inputs are on one side of the package while all the outputs are on the other side.

### Features

- Switching specifications at 50 pF
- Switching specifications guaranteed over full temperature and  $V_{CC}$  range
- Advanced oxide-isolated, ion-implanted Schottky TTL process
- Functionally equivalent with S373
- Improved AC performance over S373 at approximately half the power
- 3-STATE buffer-type outputs drive bus lines directly
- Bus structured pinout

### Connection Diagram

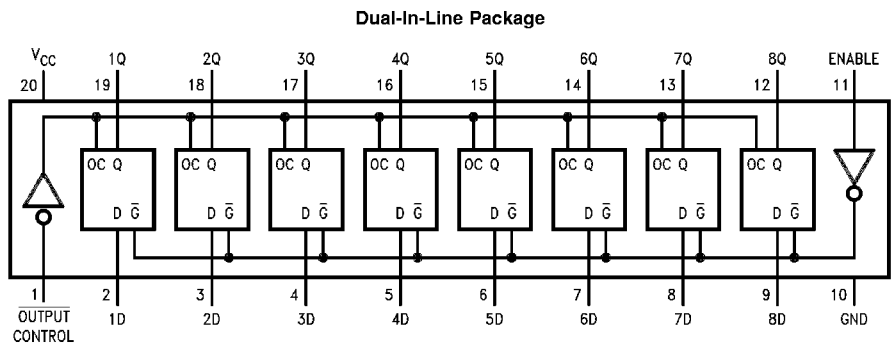

Order Number DM74AS573WM or DM74AS573N  
See Package Number M20B or N20A

DM74AS573 Octal D-Type Transparent Latch with 3-STATE Outputs

## Absolute Maximum Ratings (Note 2)

Supply Voltage	7V	Temperature Range	0°C to +70°C
Input Voltage	7V	Storage Temperature Range	-65°C to +150°C
Voltage Applied to Disabled Output	5.5V	Typical $\theta_{JA}$	
Operating Free Air		N Package	52.0°C/W
		M Package	70.0°C/W

## Recommended Operating Conditions

Symbol	Parameter	Min	Nom	Max	Units
$V_{CC}$	Supply Voltage	4.5	5	5.5	V
$V_{IH}$	High Level Input Voltage	2			V
$V_{IL}$	Low Level Input Voltage			0.8	V
$I_{OH}$	High Level Output Current			-15	mA
$I_{OL}$	Low Level Output Current			48	mA
$t_w$	Width of Enable Pulse	High	4.5		ns
		Low	5.5		
$t_{SU}$	Data Setup Time (Note 3)	2 $\uparrow$			ns
$t_H$	Data Hold Time (Note 3)	3 $\uparrow$			ns
$T_A$	Free Air Operating Temperature	0		70	°C

**Note 1:** This product meets application requirements of 500 temperature cycles from -65°C to +150°C.

**Note 2:** The "Absolute Maximum Ratings" are those values beyond which the safety of the device cannot be guaranteed. The device should not be operated at these limits. The parametric values defined in the "Electrical Characteristics" table are not guaranteed at the absolute maximum ratings. The "Recommended Operating Conditions" table will define the conditions for actual device operation.

**Note 3:** The ( $\uparrow$ ) arrow indicates the positive edge of the Clock is used for reference.

## Electrical Characteristics

over recommended operating free air temperature range. All typical values are measured at  $V_{CC} = 5V$ ,  $T_A = 25^\circ C$ .

Symbol	Parameter	Conditions	Min	Typ	Max	Units
$V_{IK}$	Input Clamp Voltage	$V_{CC} = 4.5V$ , $I_I = -18$ mA			-1.2	V
$V_{OH}$	High Level Output Voltage	$V_{CC} = 4.5V$ , $V_{IL} = \text{Max}$ , $I_{OH} = \text{Max}$	2.4	3.3		V
		$V_{CC} = 4.5V$ to $5.5V$ , $I_{OH} = -2$ mA	$V_{CC} - 2$			
$V_{OL}$	Low Level Output Voltage	$V_{CC} = 4.5V$ , $V_{IH} = 2V$		0.35	0.5	V
		$I_{OL} = \text{Max}$				
$I_I$	Input Current @ Max Input Voltage	$V_{CC} = 5.5V$ , $V_{IH} = 7V$			0.1	mA
$I_{IH}$	High Level Input Current	$V_{CC} = 5.5V$ , $V_{IH} = 2.7V$			20	$\mu A$
$I_{IL}$	Low Level Input Current	$V_{CC} = 5.5V$ , $V_{IL} = 0.4V$			-0.5	mA
$I_O$ (Note 4)	Output Drive Current	$V_{CC} = 5.5V$ , $V_O = 2.25V$	-30		-112	mA
$I_{OZH}$	Off-State Output Current, High Level Voltage Applied	$V_{CC} = 5.5V$ , $V_{IH} = 2V$ , $V_O = 2.7V$			50	$\mu A$
$I_{OZL}$	Off-State Output Current, Low Level Voltage Applied	$V_{CC} = 5.5V$ , $V_{IH} = 2V$ , $V_O = 0.4V$			-50	$\mu A$
$I_{CC}$	Supply Current	$V_{CC} = 5.5V$ Outputs Open	Outputs High	56	93	mA
			Outputs Low	55	90	
		Outputs Disabled	65	106		

**Note 4:** The output conditions have been chosen to produce a current that approximates one half of the true short-circuit output current,  $I_{OS}$ .

## Switching Characteristics

over recommended operating free air temperature range (Note 5)

Symbol	Parameter	Conditions	From	To	Min	Max	Units
t <sub>PLH</sub>	Propagation Delay Time Low to High Level Output	V <sub>CC</sub> = 4.5V to 5.5V R <sub>L</sub> = 500Ω C <sub>L</sub> = 50 pF	Data	Any Q	3	6	ns
t <sub>PHL</sub>	Propagation Delay Time High to Low Level Output		Data	Any Q	3	6	ns
t <sub>PLH</sub>	Propagation Delay Time Low to High Level Output		Enable	Any Q	6	11.5	ns
t <sub>PHL</sub>	Propagation Delay Time High to Low Level Output		Enable	Any Q	4	7.5	ns
t <sub>PZH</sub>	Output Enable Time to High Level Output		$\overline{\text{Output}}$ Control	Any Q	2	6.5	ns
t <sub>PZL</sub>	Output Enable Time to Low Level Output		$\overline{\text{Output}}$ Control	Any Q	4	9.5	ns
t <sub>PHZ</sub>	Output Disable Time from High Level Output		$\overline{\text{Output}}$ Control	Any Q	2	6.5	ns
t <sub>PLZ</sub>	Output Disable Time from Low Level Output		$\overline{\text{Output}}$ Control	Any Q	2	7	ns

**Note 5:** See Section 5 for test waveforms and output load.

## Function Table

Output Control	Enable G	D	Output Q
L	H	H	H
L	H	L	L
L	L	X	Q <sub>0</sub>
H	X	X	Z

L = Low State  
H = High State  
X = Don't Care  
Z = High Impedance State  
Q<sub>0</sub> = Previous Condition of Q

# Logic Diagram

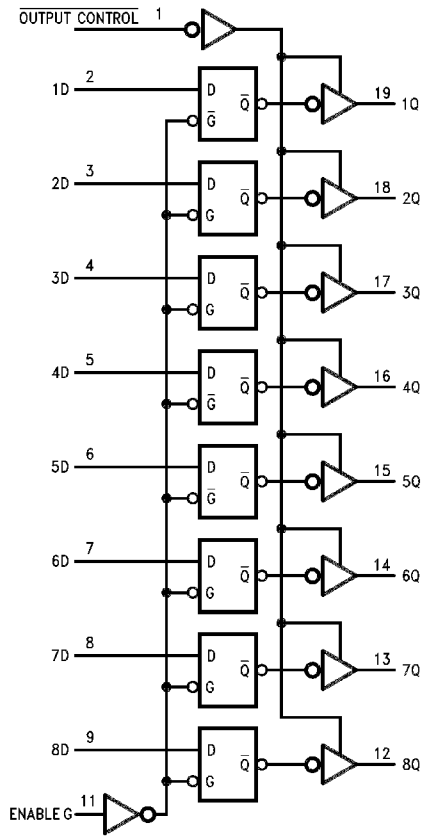

DS006313-2

**Physical Dimensions** inches (millimeters) unless otherwise noted

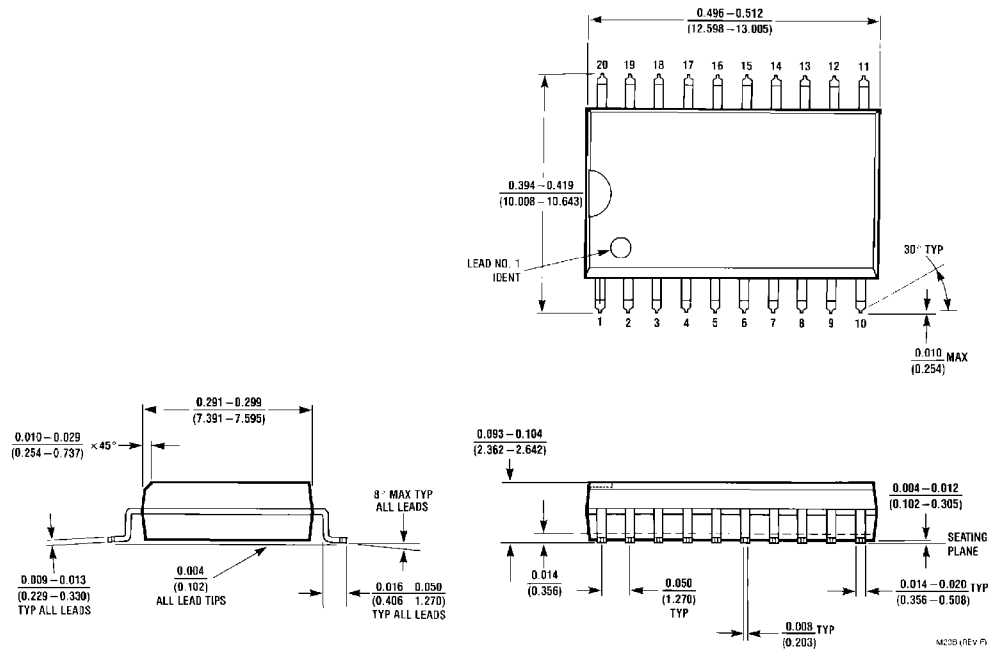

**20-Lead (0.300" Wide) Molded  
Small Outline Package, JEDEC  
Order Number DM74AS573WM  
Package Number M20B**

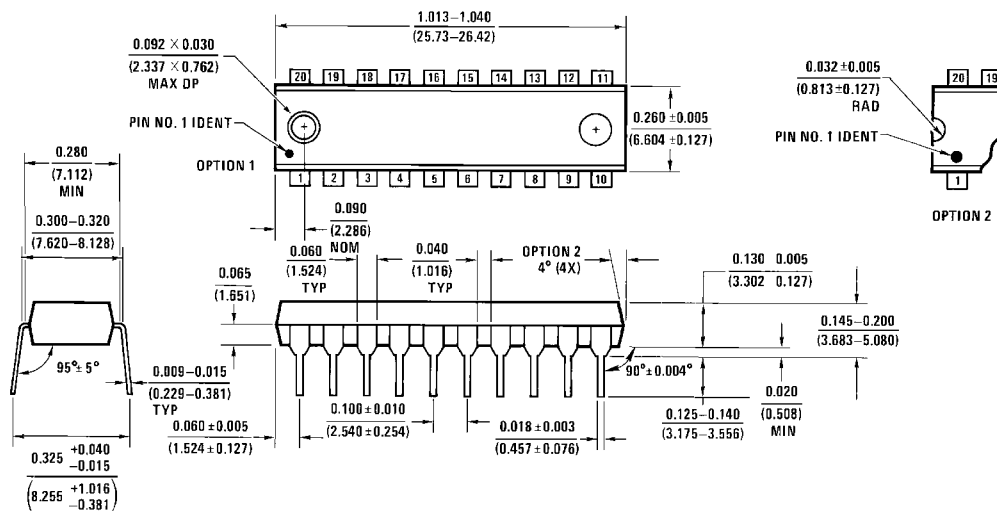

**Molded Dual-In-Line Package (N)  
Order Number DM74AS573N  
Package Number N20A**

**LIFE SUPPORT POLICY**

FAIRCHILD'S PRODUCTS ARE NOT AUTHORIZED FOR USE AS CRITICAL COMPONENTS IN LIFE SUPPORT DEVICES OR SYSTEMS WITHOUT THE EXPRESS WRITTEN APPROVAL OF THE PRESIDENT OF FAIRCHILD SEMICONDUCTOR CORPORATION. As used herein:

1. Life support devices or systems are devices or systems which, (a) are intended for surgical implant into the body, or (b) support or sustain life, and (c) whose failure to perform when properly used in accordance with instructions for use provided in the labeling, can be reasonably expected to result in a significant injury to the user.
2. A critical component in any component of a life support device or system whose failure to perform can be reasonably expected to cause the failure of the life support device or system, or to affect its safety or effectiveness.

**Fairchild Semiconductor Corporation Americas**  
Customer Response Center  
Tel: 1-888-522-5372

**Fairchild Semiconductor Europe**  
Fax: +49 (0) 1 80-530 85 86  
Email: europe.support@nsc.com  
Deutsch Tel: +49 (0) 8 141-35-0  
English Tel: +44 (0) 1 793-85-68-56  
Italy Tel: +39 (0) 2 57 5631

**Fairchild Semiconductor Hong Kong Ltd.**  
13th Floor, Straight Block,  
Ocean Centre, 5 Canton Rd.  
Tsimshatsui, Kowloon  
Hong Kong  
Tel: +852 2737-7200  
Fax: +852 2314-0061

**National Semiconductor Japan Ltd.**  
Tel: 81-3-5620-6175  
Fax: 81-3-5620-6179

[www.fairchildsemi.com](http://www.fairchildsemi.com)