

KK74LS14

Hex Schmitt-Trigger Inverter

This device contains six independent gates each of which performs the logic INVERT function. Each input has hysteresis which increases the noise immunity and transforms a slowly changing input signal to a fast changing, jitter free output.

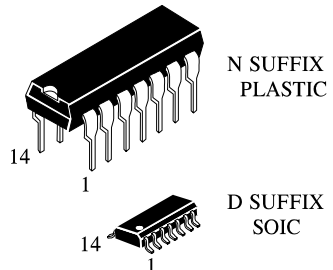

N SUFFIX
PLASTIC

D SUFFIX
SOIC

ORDERING INFORMATION
 KK74LS14N Plastic
 KK74LS14D SOIC
 T_A = 0° to 70° C for all packages

LOGIC DIAGRAM

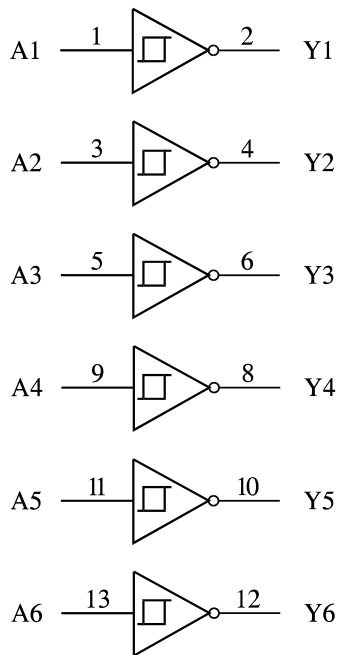

PIN 14 = V_{CC}
 PIN 7 = GND

PIN ASSIGNMENT

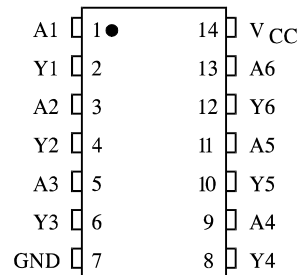

FUNCTION TABLE

Inputs	Output
A	Y
L	H
H	L

MAXIMUM RATINGS*

Symbol	Parameter	Value	Unit
V _{CC}	Supply Voltage	7.0	V
V _{IN}	Input Voltage	7.0	V
V _{OUT}	Output Voltage	5.5	V
T _{stg}	Storage Temperature Range	-65 to +150	°C

*Maximum Ratings are those values beyond which damage to the device may occur. Functional operation should be restricted to the Recommended Operating Conditions.

RECOMMENDED OPERATING CONDITIONS

Symbol	Parameter	Min	Max	Unit
V _{CC}	Supply Voltage	4.75	5.25	V
I _{OH}	High Level Output Current		-15	mA
I _{OL}	Low Level Output Current		24	mA
T _A	Ambient Temperature Range	0	+70	°C

DC ELECTRICAL CHARACTERISTICS over full operating conditions

Symbol	Parameter	Test Conditions	Guaranteed Limit		Unit
			Min	Max	
V _{T+}	Positive-Going Input Threshold Voltage	V _{CC} = 5 V	0.5	1	V
V _{T-}	Negative-Going Input Threshold Voltage	V _{CC} = 5 V	1.4	1.9	V
V _{T+} - V _{T-}	Hysteresis	V _{CC} = 5 V	0.4		V
V _{IK}	Input Clamp Voltage	V _{CC} = min, I _{IN} = -18 mA		-1.5	V
V _{OH}	High Level Output Voltage	V _{CC} = min, I _{OH} = -0.4 mA, V _I = 0.5 V	2.7		V
V _{OL}	Low Level Output Voltage	V _{CC} = min, I _{OL} = 4 mA, V _I = 1.9 V		0.4	V
		V _{CC} = min, I _{OL} = 8 mA, V _I = 1.9 V		0.5	
I _{IH}	High Level Input Current	V _{CC} = max, V _{IN} = 2.7 V		20	μA
		V _{CC} = max, V _{IN} = 7.0 V		0.1	mA
I _{IL}	Low Level Input Current	V _{CC} = max, V _{IN} = 0.4 V		-0.4	mA
I _O	Output Short Circuit Current	V _{CC} = max, V _O = 0 V (Note 1)	-20	-100	mA
I _{CC}	Supply Current	Total with outputs high		16	mA
		Total with outputs low		21	

Note 1: Not more than one output should be shorted at a time, and the duration should not exceed one second.

AC ELECTRICAL CHARACTERISTICS ($T_A = 25^\circ\text{C}$, $V_{CC} = 5.0\text{ V}$, $C_L = 15\text{ pF}$,
 $R_L = 2\text{ k}\Omega$, $t_r = 15\text{ ns}$, $t_f = 6.0\text{ ns}$)

Symbol	Parameter	Min	Max	Unit
t_{PLH}	Propagation Delay, Input A to Output Y		22	ns
t_{PHL}	Propagation Delay, Input A to Output Y		22	ns

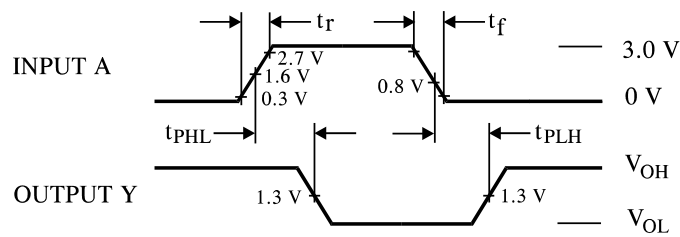
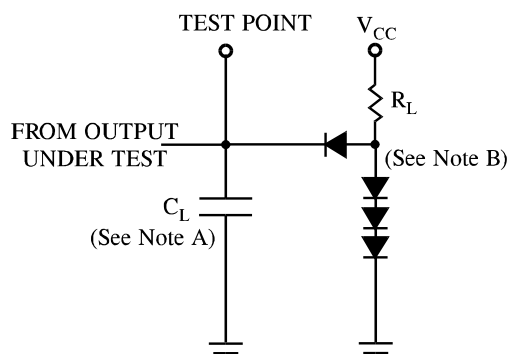

Figure 1. Switching Waveforms



NOTES A. C_L includes probe and jig capacitance.
 B. All diodes are 1N916 or 1N3064.

Figure 2. Test Circuit

**N SUFFIX PLASTIC DIP
(MS - 001AA)**

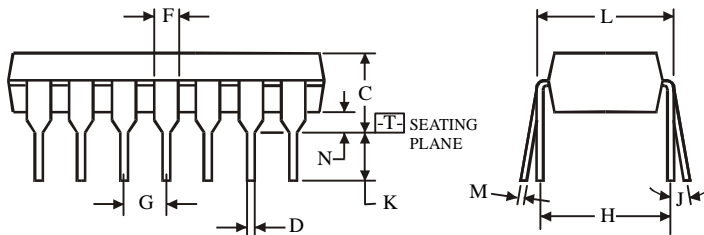
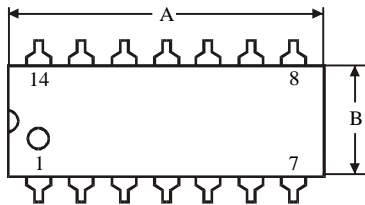
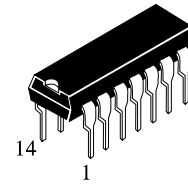

$\oplus 0.25 (0.010) \text{ (M) T}$

NOTES:

- Dimensions "A", "B" do not include mold flash or protrusions.
Maximum mold flash or protrusions 0.25 mm (0.010) per side.

Symbol	Dimension, mm	
	MIN	MAX
A	18.67	19.69
B	6.1	7.11
C		5.33
D	0.36	0.56
F	1.14	1.78
G	2.54	
H	7.62	
J	0°	10°
K	2.92	3.81
L	7.62	8.26
M	0.2	0.36
N	0.38	

**D SUFFIX SOIC
(MS - 012AB)**

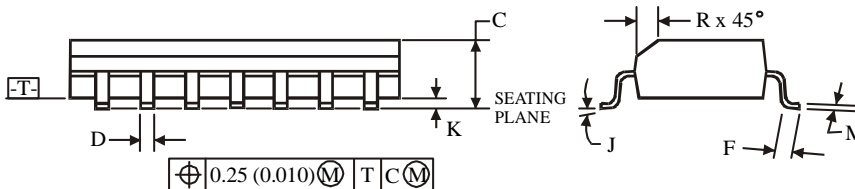
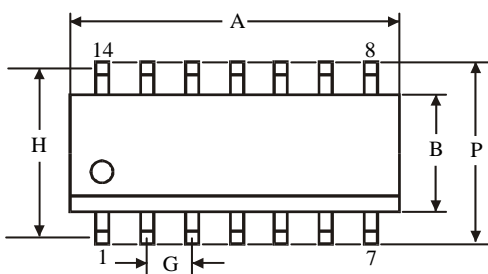
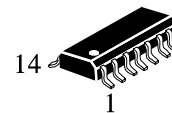

$\oplus 0.25 (0.010) \text{ (M) T C (M)}$

NOTES:

- Dimensions A and B do not include mold flash or protrusion.
- Maximum mold flash or protrusion 0.15 mm (0.006) per side for A; for B - 0.25 mm (0.010) per side.

Symbol	Dimension, mm	
	MIN	MAX
A	8.55	8.75
B	3.8	4
C	1.35	1.75
D	0.33	0.51
F	0.4	1.27
G	1.27	
H	5.27	
J	0°	8°
K	0.1	0.25
M	0.19	0.25
P	5.8	6.2
R	0.25	0.5