

PRODUCT NUMBER
77311-YXX-XXLF

PLATING SEE SHEET 2

PIN STYLE SEE SHEET 2

RoHS COMPATIBLE
SEE NOTE 6

TOTAL NB OF POSITIONS 01 TO 36

OPTION LETTER SEE NOTE 7

PRODUCT NUMBER (BERGSTRIK PACKAGING)
77311-YXX-OOLF

PLATING

1= 0.76µm GOLD/GXT ON CONTACT AREA, 2µm TIN MIN ON TAILS

8= 0.38µm GOLD/GXT ON CONTACT AREA, 2µm TIN MIN ON TAILS

4= 2.0µm TIN MIN FULL PLATED

1.27µm NICKEL MIN UNDERLAYER FOR ALL PLATING VERSIONS

INDICATES THE PRODUCT IS RoHS COMPATIBLE, SEE NOTE 6

POSITIONS PER REEL : 00=36,000 (BERGSTRIK)

PIN STYLE	MATING	SOLDER	OAL
01	5.84	2.41	10.8
02	5.84	3.42	11.8
18	5.84	3.05	11.43
22	7.75	3.05	13.35
24	6.75	2.9	12.2
27	6.6	2.66	11.8

NOTES:

- HOUSING MAT'L : HIGH TEMPERATURE THERMOPLASTIC. UL94V-0 COLOR: BLACK
- PIN MATERIAL : PHOSPHOR BRONZE
- BERGSTIK PRODUCT PACKAGED IN POLYBAGS. BERGSTRIK PRODUCT PACKAGED PER REELS.
- 9N MIN RETENTION IN EITHER DIRECTION
- TO DETERMINE DIMENSIONS :
N = NUMBER OF POSITIONS PER ROW
EXAMPLE : 8 POS N x 2.54 = 20.32mm
- RoHS COMPATIBLE PRODUCT SPECIFICATIONS
 - a - PLATING:
 - "LF" MEANS THE PRODUCT IS LEAD-FREE, 2µm MINIMUM MATTE TIN OVER 1.27µm MINIMUM NICKEL UNDERPLATE.
 - b - MANUFACTURING PROCESS COMPATIBILITY
 - THE HOUSING WILL WITHSTAND EXPOSURE TO 260°C ±5°C SOLDER BATH TEMPERATURE FOR 5 SECONDS IN A WAVE SOLDER APPLICATION WITH A 1.6mm MIN THICK CIRCUIT BOARD.
 - REFLOW COMPATIBLE
 - c - LABELING:
 - MEETS PACKAGING SPECS AS PER GS-14-920
 - d - LEGAL STATEMENT: SEE GS-47-0004

7. OPTION LETTER :

- T = TUBE PACKAGING WITHOUT PICK UP CAP
- K = TAPE & REEL PACKAGING, WITHOUT PICK UP CAP ONLY FOR P/N 77311-462K04(LF) AND 77311-462K05(LF)
- KC = TAPE & REEL PACKAGING WITHOUT PICK UP CAP AND WITH HIGH RETENTION FEATURES
- KV = TAPE & REEL PACKAGING WITHOUT PICK UP CAP FOR CUSTOMER DEDICATED PART ONLY FOR P/N 77311-462KV04LF
- C = HIGH RETENTION FEATURES, SEE SHEET 2
- R = RETENTION FEATURES, SEE SHEET 2
IF RETENTION FEATURE "R" AND TUBE PACKAGING "T" ARE BOTH REQUIRED
OPTIONAL LETTER "R" WILL APPEAR INSTEAD OF THE FIRST DASH
EXAMPLE : 77311R424T03LF

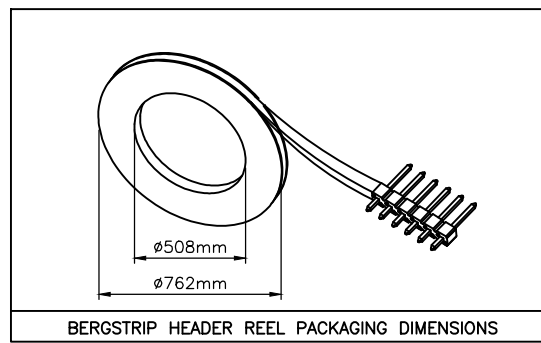
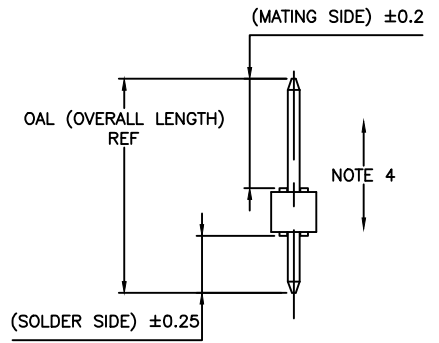
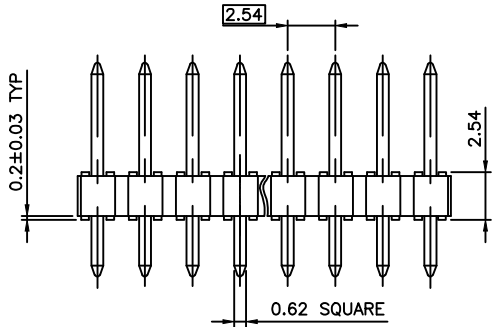
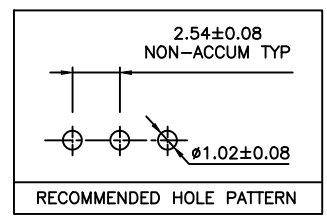
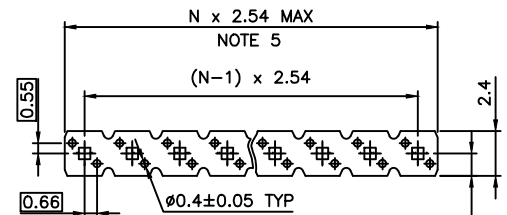

mat'l. code SEE NOTES		surface ISO 1302 ✓		tolerance ISO 406 ISO 1101		projection mm		product family BERGSTIK	
ltr	ecn no	dr	date	tolerances unless otherwise specified		mm		title	
CF	F-22085	LMU	15.10.05	angles	.x ± 0.3	mm		UNSHR.HEADER	
CG	F-22100	AMA	15.10.08	linear	.xx ± 0.15	mm		STR SR TMT	
CH	F-22133	AMA	15.10.12		.xxx ± 0.05	scale 5:1		dwg no	
CJ	F-23581	AMA	16.03.22	dr	D.LE	01.01.24	sheet 1 of 3		size
CK	F-24496	AMA	16.07.13	enrg	JM.C	01.01.24	77311		A3
CL	F-24977	DDE	16.09.20	chr	JM.C	01.01.24	type		CUSTOMER Drawing
				appd	JF.N	01.01.24			
sheet index	revision sheet	CL	BW	C					
		1	2	3					

FCconnect.com
 Copyright FCJ

PLATING

- 1 = 0.76µm GOLD/GXT ON CONTACT AREA, 2µm TIN MIN ON TAIL
- 4 = 2µm TIN MIN FULL PLATED
- 5 = 0.25µm GOLD/GXT ON CONTACT AREA, 2µm TIN MIN ON TAIL
- 8 = 0.38µm GOLD/GXT ON CONTACT AREA, 2µm TIN MIN ON TAIL
- G = 0.76µm FULL GXT
- S = 0.38µm FULL GXT
- T = 2µm TIN MIN FULL PLATED INCLUDED PIN TYP
 - 1.27µm NICKEL MIN UNDERLAYER FOR ALL PLATING VERSIONS

RETENTION FEATURES :

- 1 - PART NUMBER 77311-XXXXXXLF: DIM "Z"=(0.99)
PART NUMBER 77311-XXXCXXLF: DIM "Z"= 1.05MIN -1.15MAX
- 2 - PINS "A" AND "B" USED FOR RETENTION.
- 3 - DIRECTION OF RETENTION SHOWN BY ARROWS.
- 4 - ON 4 TO 36 POSITIONS HEADER; RETENTION IS IN MID POSITION OF HEADER (4 CENTRAL PINS)
- 5 - FOR RETENTION OPTION , SOLDER TAIL LENGTH TO BE 2.9 MIN UP TO 3.5 MAX.
- 6 - HOUSING MATERIAL FOR P/N 77311-4AJC03LF & 77311-TAJC03LF HIGH TEMPERATURE THERMOPLASTIC UL94V-0 COLOR : NATURAL

PLATING SPECIFICATIONS :

- 7 - ONLY FOR PLATING 1XX, 8.0MM GOLD / GXT PLATING AREA FROM PIN TYPE ON MATING SIDE

RETENTION FEATURES

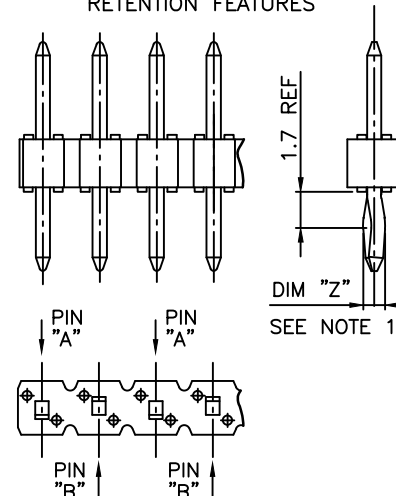

DIM "Z"
SEE NOTE 1



Copyright FCI

mat'l. code		surface		tolerance		projection		product family	
		ISO 1302 ✓		ISO 406 ISO 1101		mm		BERGSTIK	
ltr		ecn no		date		tolerances unless otherwise specified		title	
BU		B-20596		AMA 15.03.30		angles		UNSHR.HEADER	
BV		F-22085		LMU 15.10.05		linear		STR SR TMT	
BW		F-22100		AMA 15.10.08		scale N/A		dwg no	
				dr		D.LE		sheet 2 of 3	
BR		B-19692		JCO 14.12.09		enr		JM.C 01.01.24	
BS		B-20169		BVE 15.02.12		chr		JM.C 01.01.24	
BT		B-20497		BVE 15.03.18		appd		JF.N 01.01.24	
sheet		revision							
index		sheet							



PRODUCTS SPECIFICATIONS

PIN	STYLE	MATING	SOLDER	OAL
01		5.84	2.41	10.8
02		5.84	3.42	11.8
03		5.72	5.09	13.35
05		5.72	10.14	18.4
08		5.72	17.78	26.04
15		8.51	2.55	13.6
18		5.84	3.05	11.43
19		12.83	3.03	18.4
20		15.37	3.04	20.95
22		7.75	3.05	13.35
24		6.75	2.9	12.2
25		8.51	3.18	14.22
27		6.6	2.65	11.8
26		15.57	2.84	20.95
29		17.5	3.46	23.5
32		10.3	3.05	15.9
38		5.84	3.82	12.2
39		11.2	3.05	16.8
46		8.08	2.98	13.6
58		14.47	3.05	20.06
62		13.5	3.05	19.09
70		6.54	3.50	12.57
83		20.46	3.00	26.00
85		5.72	8.51	16.76
87		6.98	3.05	12.57
91		5.6	10.21	18.35
92		5.65	12.76	20.95
93		6.00	4.81	13.35
94		15.60	3.20	21.25

NOTE 7

PRODUCTS SPECIFICATIONS

PIN	STYLE	MATING	SOLDER	OAL
95		10.00	8.45	20.95
96		10.95	3.05	16.55
97		9.00	3.55	15.09
98		3.00	1.35	6.84
99		24.00	3.05	29.50
AA		5.72	15.24	23.50
AB			N/A	
AC		7.21	3.05	12.80
AD		17.53	3.43	23.50
AE		4.99	2.80	10.33
AF		5.72	3.05	11.30
AG		5.84	4.95	13.33
AH		14.31	3.20	20.05
AJ		8.90	3.40	14.85
AK		25.06	3.00	30.80
AL		3.30	3.30	9.14
AM		9.26	3.05	14.85
AN		7.60	4.40	14.47
AP		7.80	3.30	13.60
AR		18.86	2.41	23.81
AS		11.91	1.45	15.90
AT		4.60	4.60	11.61
AU		12.10	3.10	17.70
AV		6.30	6.30	15.10
AW		9.16	1.80	13.50
AX		5.08	2.43	10.05
AY		7.49	3.47	13.50
BA		8.08	2.75	13.37
BB		10.80	2.15	15.50
BC		8.08	3.81	14.43
BD		10.10	2.16	14.80
BE		13.65	2.41	18.60
BF		2.54	5.32	10.40
BG		4.98	1.85	9.23
BH		4.69	2.41	9.50
BJ		7.21	6.15	15.90
BK		6.86	2.65	12.05

NOTE 6



Copyright FCI

mat'l. code		surface		tolerance		projection		product family	
		ISO 1302 <input checked="" type="checkbox"/>		ISO 406 ISO 1101				BERGSTIK	
ltr		ecn no		dr		date		title	
A		F-22100		AMA		15.10.08		UNSHR.HEADER	
B		F-22133		AMA		15.10.12		STR SR TMT	
C		F-24496		AMA		16.07.13		scale N/A	
		dr		A.MA		15.10.08		dwg no	
		enr		L.MU		15.10.08		sheet 3 of 3	
		chr		J.CO		15.10.08		size	
		appd		A.SO		15.10.08		A3	
sheet		revision						type	
index		sheet						CUSTOMER Drawing	

