

REVISION BC

DO NOT SCALE FROM THIS PRINT

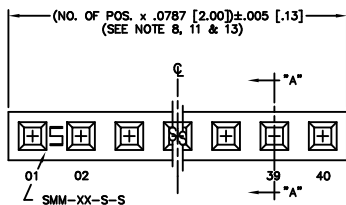

IN PROCESS

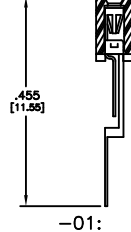

NOTES:

1. RETENTION FORCE IN BODY TO BE: 1 lbs. MIN
2. INSERTION FORCE TO BE: 3.0 oz. MAX.
3. WITHDRAWAL FORCE TO BE: 0.4 oz. MIN.
4. ⊕ REPRESENTS CRITICAL DIMS. FOR STATISTICAL PROCESS CONTROL.
5. [] DIMS ARE IN METRIC AND ARE NOT CONTROLLING DIMS.
6. SMM-105-01-X THRU SMM-140-01-X MUST USE PT-1-24-01-12.
7. *-LC* OPTION FOR A 02 POSITION WILL HAVE ONLY ONE LOCKING CLIP (LC-05-T).
8. "END WALLS" AFTER CUTTING SHOULD BE .017±.005.
9. ALL OPTIONS: PACKAGE POSITIONS -04 THRU -40 IN TUBES. LAYER PACKAGE POSITIONS -02 & -03 WITH NO OPTIONS.
10. -02 THRU -05 POSITION WITH -K OR -P TO BE PACKAGED IN -TR ONLY. -06 THRU -40 POSITION AVAILABLE IN TUBE OR -TR PACKAGING.
11. MAX CUT FLASH: .010[.25]
12. DUE TO THE HIGH AMOUNT OF INSERTION FORCE NEEDED, THE -LC OPTION IS NOT COMPATIBLE WITH AUTO PLACEMENT. SAMTEC RECOMMENDS MANUAL PLACEMENT FOR ALL ASSEMBLIES WITH THE -LC OPTION.
13. FOR -02 LEAD STYLE: EVEN CUTS: LOSE 2 POSITIONS PER CUT; ODD CUTS: LOSE 1 POSITION PER CUT.
14. INSULATOR MATERIAL: BLACK, LCP, UL 94 VO

DIMENSIONS ARE IN INCHES UNLESS OTHERWISE NOTED		TOLERANCES AND ANGLES	TITLE	DWG NO:
ONE PLACE DECIMALS: ± .1	THREE PLACE DECIMALS: ± .005	± 1°	2 mm SOCKET STRIP (SINGLE ROW)	SMM-1XX-XX-XX-S-XX-XX-XX
TWO PLACE DECIMALS: ± .01	FOUR PLACE DECIMALS: ± .0020		(SINGLE ROW)	SHEET 1 OF 1

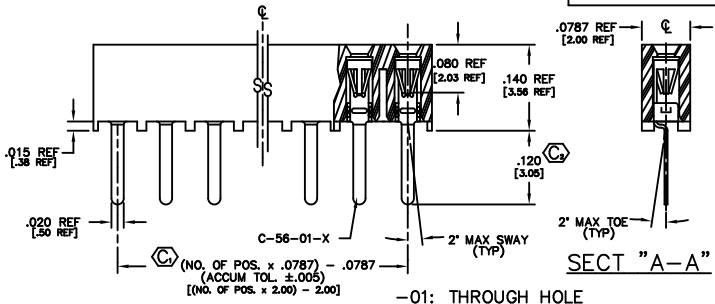
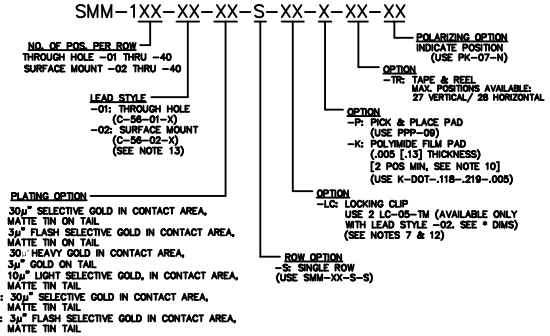

SECTION "A-A"

* PINS INTERLEAVED AND ORIENTED SAME DIRECTION FOR -01 ONLY

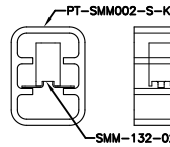

TUBE PACKAGING TABLE

LEAD STYLE	TUBE	PLUG
-01	PT-1-24-01-12	TP-12
-01-P	PT-1-24-02-29	TP-24
-02		
-02-K, -02-LC, -02-LC-K	PT-SMM002-S-K	TP-24-02
-02-P	PT-SMM001-S-P	TP-24

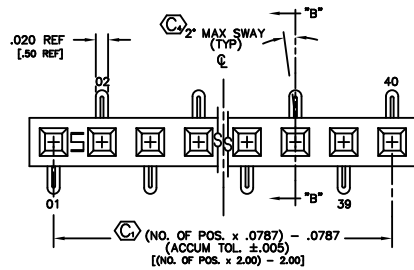

IN PROCESS

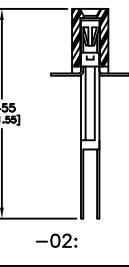

PACKAGE PARTS IN TUBE AS SHOWN (POSITION PARTS WITH POS. -01 TOWARD ARROW AS SHOWN)

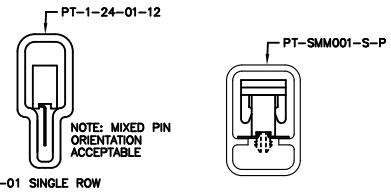

-01 SINGLE ROW

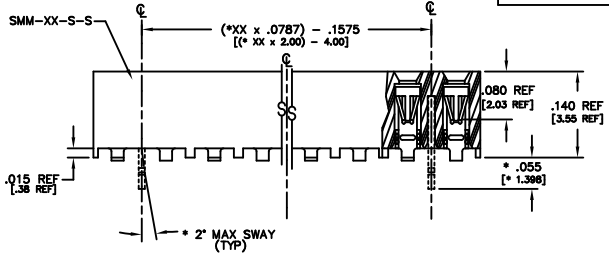

-02: SURFACE MOUNT

SECTION "B-B"

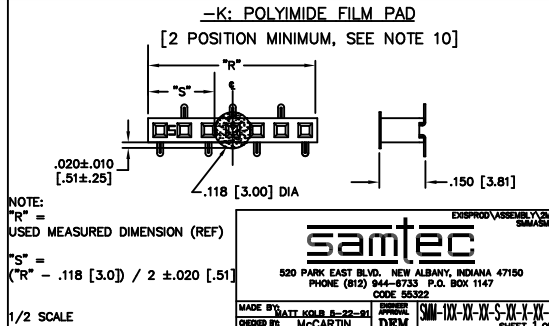
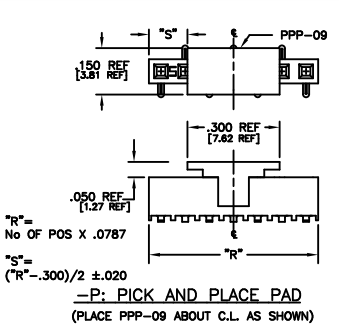
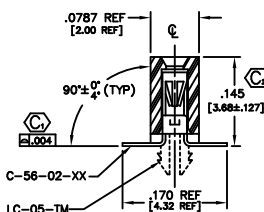

NOTE: "R" = USED MEASURED DIMENSION (REF) "S" = ("R" - .118 [3.0]) / 2 ± .020 [5.1] 1/2 SCALE

DISPROD/ASSEMBLY/20M/SMASB-S

samtec

520 PARK EAST BLVD. NEW ALBANY, INDIANA 47150
PHONE (812) 944-8733 P.O. BOX 1147
CODE 55322

MADE BY: MATT KOHL R-22-R
DESIGNED BY: MCCARTIN
CODE: DEM

SMM-1XX-XX-XX-S-XX-XX-XX
SHEET 1 OF 1

PROPRIETARY NOTE
THIS DOCUMENT AND THE INFORMATION CONTAINED HEREIN ARE THE PROPERTY OF SAMTEC. NO PART OF THIS DOCUMENT IS TO BE REPRODUCED OR TRANSMITTED IN ANY FORM OR BY ANY MEANS, ELECTRONIC OR MECHANICAL, INCLUDING PHOTOCOPYING, RECORDING, OR BY ANY INFORMATION STORAGE AND RETRIEVAL SYSTEM, WITHOUT THE WRITTEN CONSENT OF SAMTEC INC.