

Monolithic Dual SPST CMOS Analog Switch

Features

- ± 15 V Input Signal Range
- 44-V Maximum Supply Ranges
- On-Resistance: 45Ω
- TTL and CMOS Compatibility

Benefits

- Wide Dynamic Range
- Simple Interfacing
- Reduced External Component Count

Applications

- Servo Control Switching
- Programmable Gain Amplifiers
- Audio Switching
- Programmable Filters

Description

The DG200A is a dual, single-pole, single-throw analog switch designed to provide general purpose switching of analog signals. This device is ideally suited for designs requiring a wide analog voltage range coupled with low on-resistance.

The DG200A is designed on Siliconix' improved

PLUS-40 CMOS process. An epitaxial layer prevents latchup.

Each switch conducts equally well in both directions when on, and blocks up to 30 V peak-to-peak when off. In the on condition, this bi-directional switch introduces no offset voltage of its own.

Functional Block Diagram and Pin Configuration

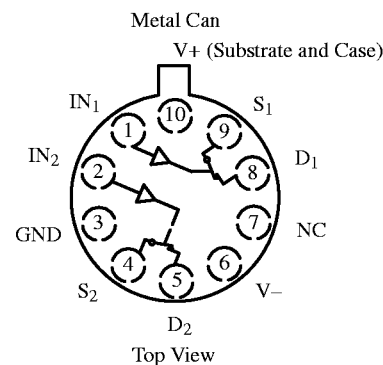
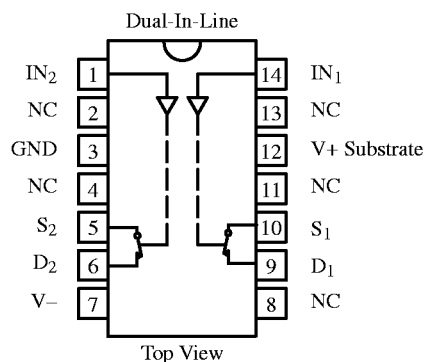

Truth Table

Logic	Switch
0	ON
1	OFF

Logic "0" ≤ 0.8 V
Logic "1" ≥ 2.4 V

Updates to this data sheet may be obtained via facsimile by calling Siliconix FaxBack, 1-408-970-5600. Please request FaxBack document #70035.

Ordering Information

Temp Range	Package	Part Number
0 to 70°C	14-Pin Plastic DIP	DG200ACJ
-25 to 85°C	14-Pin CerDIP	DG200ABK
	10-Pin Metal Can	DG200ABA
-55 to 125°C	14-Pin CerDIP	DG200AAK
		DG200AAK/883, JM38510/12301BCA
	10-Pin Metal Can	DG200AAA
		DG200AAA/883, JM38510/12301BIC
		14-Pin Sidebrazed

Absolute Maximum Ratings

V+ to V-	44 V
GND to V-	25 V
Digital Inputs ^a , V _S , V _D	(V-) -2 V to (V+) +2 V or 30 mA, whichever occurs first
Current (Any Terminal) Continuous	30 mA
Current S or D (Pulsed at 1 ms, 10% Duty Cycle Max)	100 mA
Storage Temperature (AX, BX Suffix)	-65 to 150°C
(CJ Suffix)	-65 to 125°C
Power Dissipation (Package) ^b	

10-Pin Metal Can ^c	450 mW
14-Pin CerDIP ^d	825 mW
14-Pin Plastic DIP ^e	470 mW

Notes:

- Signals on S_X, D_X, or IN_X exceeding V+ or V- will be clamped by internal diodes. Limit forward diode current to maximum current ratings.
- All leads welded or soldered to PC Board.
- Derate 6 mW/°C above 75°C
- Derate 11 mW/°C above 75°C
- Derate 6.5 mW/°C above 25°C

Schematic Diagram (Typical Channel)

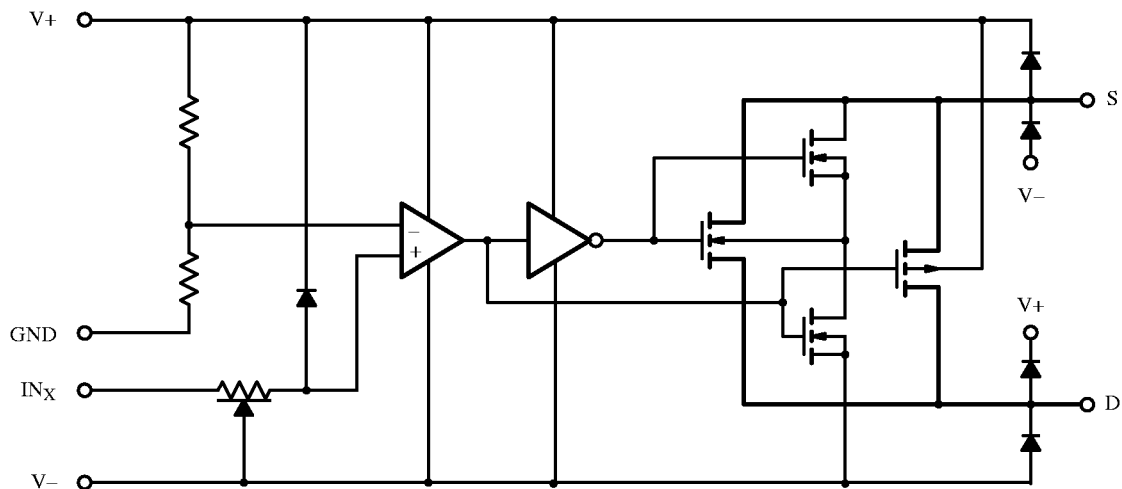

Figure 1.

Specifications^a

Parameter	Symbol	Test Conditions Unless Otherwise Specified $V_+ = 15\text{ V}$, $V_- = -15\text{ V}$ $V_{IN} = 2.4\text{ V}$, 0.8 V^f	Temp ^b	Typ ^c	A Suffix -55 to 125°C		B, C Suffix		Unit
					Min ^d	Max ^d	Min ^d	Max ^d	
Analog Switch									
Analog Signal Range ^e	V_{ANALOG}		Full		-15	15	-15	15	V
Drain-Source On-Resistance	$r_{DS(on)}$	$V_D = \pm 10\text{ V}$, $I_S = -1\text{ mA}$	Room Full	45		70 100		80 100	Ω
Source Off Leakage Current	$I_{S(off)}$	$V_S = \pm 14\text{ V}$, $V_D = \mp 14\text{ V}$	Room Full	± 0.01	-2 -100	2 100	-5 -100	5 100	nA
Drain Off Leakage Current	$I_{D(off)}$	$V_D = \pm 14\text{ V}$, $V_S = \mp 14\text{ V}$	Room Full	± 0.01	-2 -100	2 100	-5 -100	5 100	
Channel On Leakage Current ^f	$I_{D(on)}$	$V_S = V_D = \pm 14\text{ V}$	Room Full	± 0.1	-2 -200	2 200	-5 -200	5 200	
Digital Control									
Input Current with Input Voltage High	I_{INH}	$V_{IN} = 2.4\text{ V}$	Room Full	0.0009	-0.5 -1		-1 -10		uA
		$V_{IN} = 15\text{ V}$	Room Full	0.005		0.5 1		1 10	
Input Current with Input Voltage Low	I_{INL}	$V_{IN} = 0\text{ V}$	Room Full	-0.0015	-0.5 -1		-1 -10		
Dynamic Characteristics									
Turn-On Time	t_{ON}	See Switching Time Test Circuit	Room	440		1000		1000	ns
Turn-Off Time	t_{OFF}		Room	340		425		425	
Charge Injection	Q	$C_L = 1000\text{ pF}$, $V_g = 0\text{ V}$ $R_g = 0\ \Omega$	Room	-10					pC
Source-Off Capacitance	$C_{S(off)}$	$f = 140\text{ kHz}$ $V_{IN} = 5\text{ V}$	Room	9					pF
Drain-Off Capacitance	$C_{D(off)}$		$V_D = 0\text{ V}$	Room	9				
Channel-On Capacitance	$C_{D(on)} + C_{S(on)}$	$V_D = V_S = 0\text{ V}$, $V_{IN} = 0\text{ V}$	Room	25					
Off Isolation	OIRR	$V_{IN} = 5\text{ V}$, $R_L = 75\ \Omega$ $V_S = 2\text{ V}$, $f = 1\text{ MHz}$	Room	75					dB
Crosstalk (Channel-to-Channel)	X_{TALK}		Room	90					
Power Supplies									
Positive Supply Current	I_+	Both Channels On or Off $V_{IN} = 0\text{ V}$ and 2.4 V	Room	0.8		2		2	mA
Negative Supply Current	I_-		Room	-0.23	-1		-1		

Notes:

- Refer to PROCESS OPTION FLOWCHART.
- Room = 25°C, Full = as determined by the operating temperature suffix.
- Typical values are for DESIGN AID ONLY, not guaranteed nor subject to production testing.
- The algebraic convention whereby the most negative value is a minimum and the most positive a maximum, is used in this data sheet.
- Guaranteed by design, not subject to production test.
- V_{IN} = input voltage to perform proper function.

Typical Characteristics

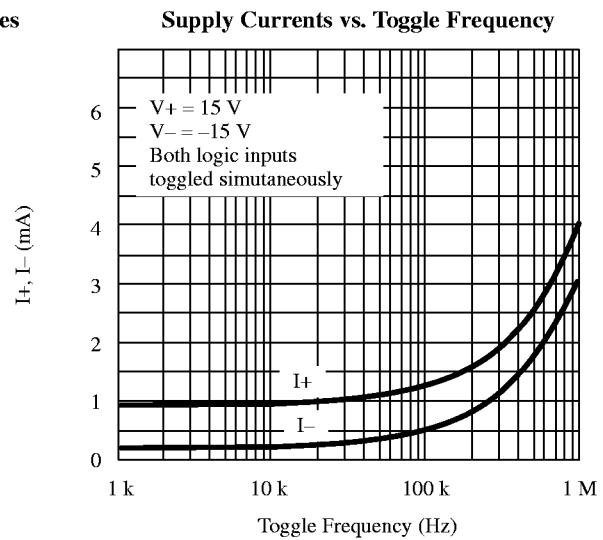
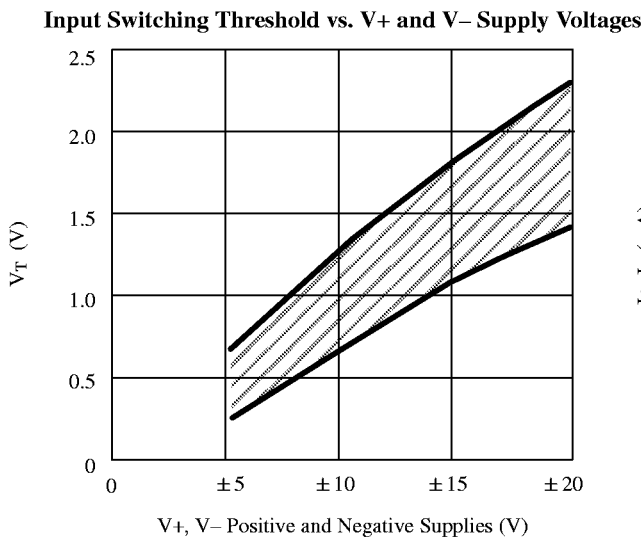
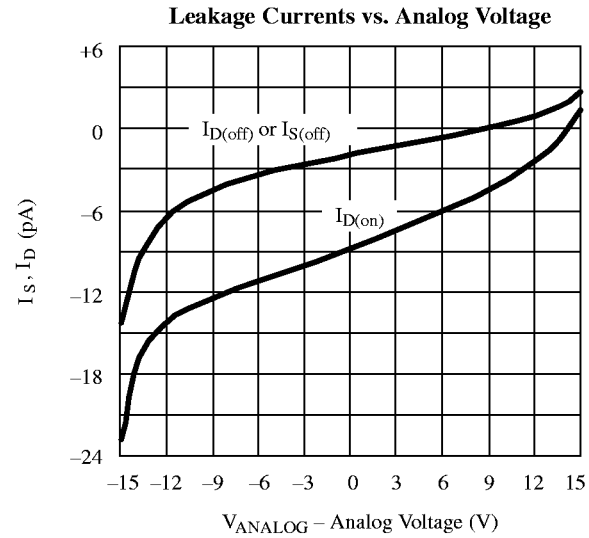
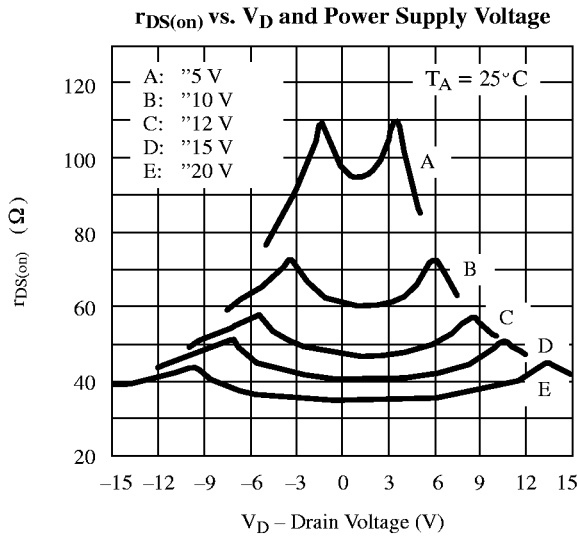

Test Circuits

V_O is the steady state output with switch on. Feedthrough via gate capacitance may result in spikes at leading and trailing edge of output waveform.

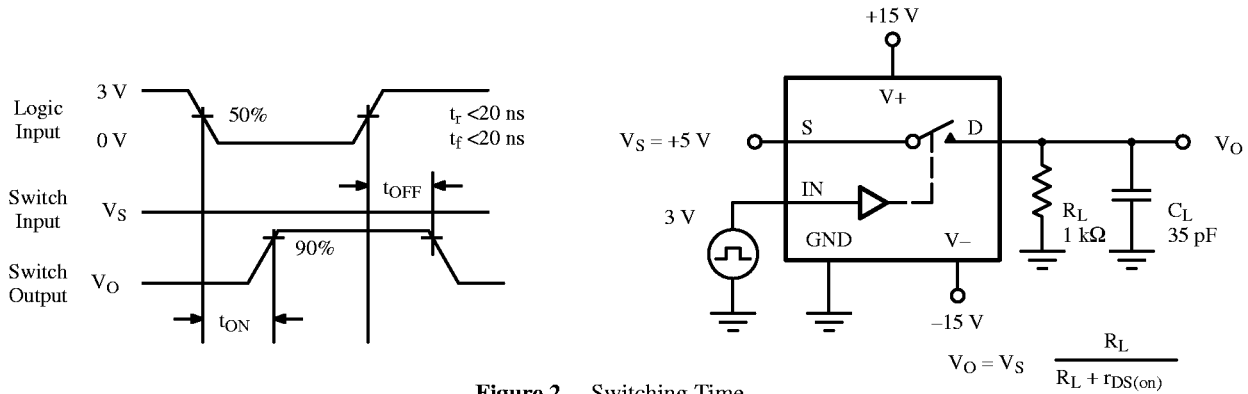

Figure 2. Switching Time

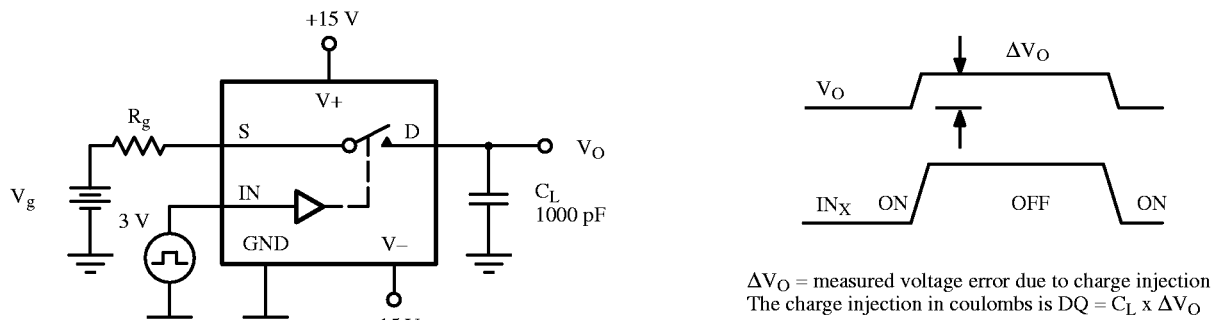

Figure 3. Charge Injection

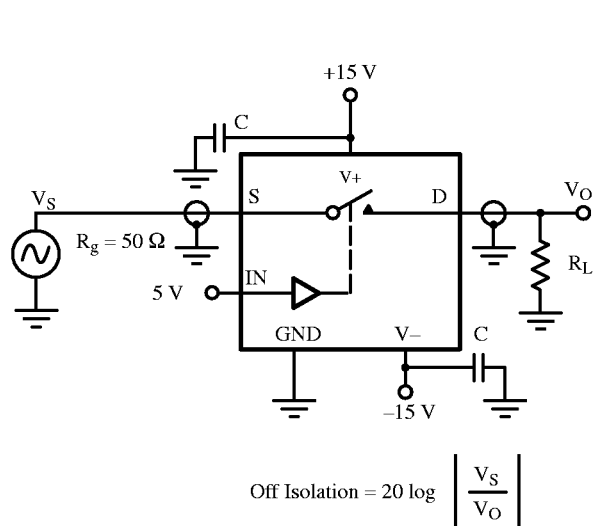

Figure 4. Off Isolation

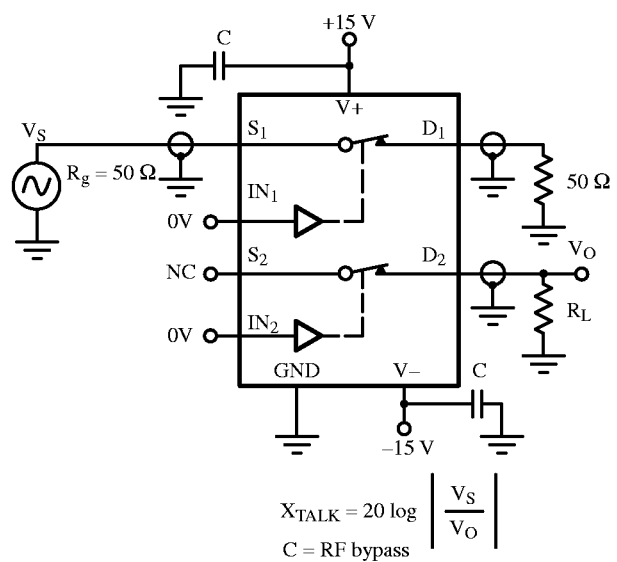
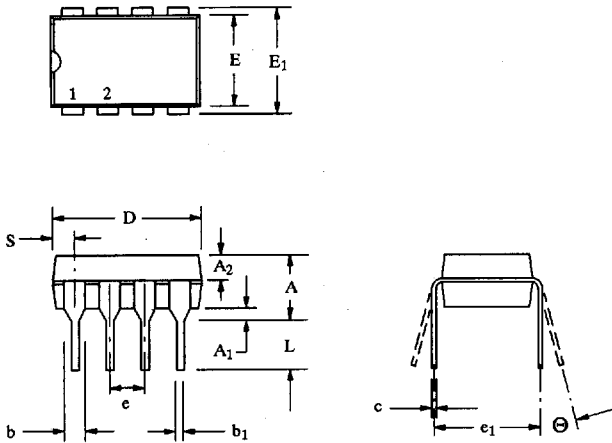

Figure 5. Channel-to-Channel Crosstalk

Package Information

Siliconix

■ Plastic DIP, 8- to 20-Pin



Dim	Millimeters		Inches	
	Min	Max	Min	Max
A	3.81	5.08	0.150	0.200
A ₁	0.38	1.27	0.015	0.050
A ₂	1.27	2.03	0.050	0.080
b	0.89	1.65	0.035	0.065
b ₁	0.38	0.51	0.015	0.020
c	0.20	0.30	0.008	0.012
D-8	9.65	11.68	0.380	0.460
D-14	17.27	19.30	0.680	0.760
D-16	18.93	21.33	0.745	0.840
D-20	24.89	26.92	0.980	1.060
E	5.59	7.11	0.220	0.280
E ₁	7.62	8.26	0.300	0.325
e	2.29	2.79	0.090	0.110
e ₁	7.37	7.87	0.290	0.310
L	2.79	3.81	0.110	0.150
S-8	1.02	2.03	0.040	0.080
S-14	1.02	2.03	0.040	0.080
S-16	0.38	1.52	0.015	0.060
S-20	1.02	2.03	0.040	0.080
⊖	0°	15°	0°	15°

■ PLCC Package, 20-Pin

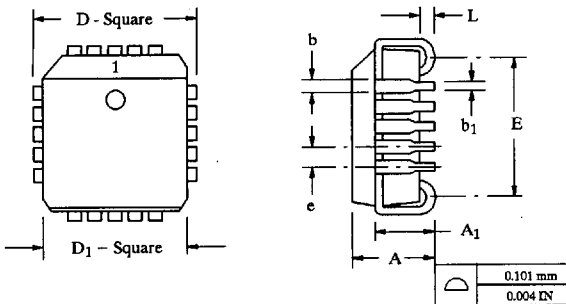

Dim	Millimeters		Inches	
	Min	Max	Min	Max
A	4.20	4.57	0.165	0.180
A ₁	2.29	3.04	0.090	0.120
b	0.66	0.81	0.026	0.032
b ₁	0.33	0.55	0.013	0.021
D	9.78	10.03	0.385	0.395
D ₁	8.89	9.04	0.350	0.356
E	7.37	8.38	0.290	0.330
e	1.27 BSC		0.050 BSC	
L	0.51	-	0.020	-

■ Sidebrazed DIP, 14- to 24-Pin

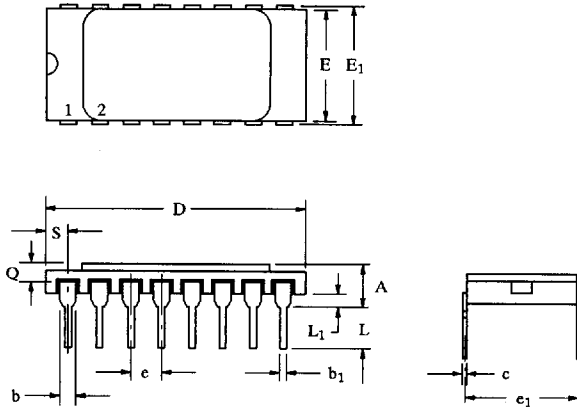

Dim	Millimeters		Inches	
	Min	Max	Min	Max
A	2.67	4.44	0.105	0.175
b	0.97	1.52	0.038	0.060
b ₁	0.38	0.53	0.015	0.021
c	0.20	0.30	0.008	0.012
D-14	17.53	19.55	0.690	0.770
D-16	19.56	21.08	0.770	0.830
D-20	24.89	26.16	0.890	1.030
D-24	29.97	31.24	1.180	1.230
E	7.12	7.87	0.280	0.310
E ₁	7.37	8.25	0.290	0.325
e	2.54 BSC		0.100 BSC	
e ₁	7.62 BSC		0.300 BSC	
L	3.18	4.44	0.125	0.175
L ₁	0.64	1.39	0.025	0.055
Q	0.25	-	0.010	-
S-14	0.77	2.41	0.030	0.095
S-16	0.51	1.65	0.020	0.065
S-20	0.77	1.65	0.030	0.065
S-24	0.77	2.41	0.030	0.095

■ SO Package, 8- to 16-Pin

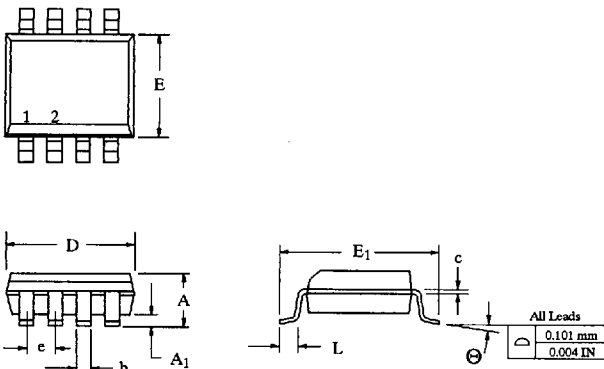

Dim	Millimeters		Inches	
	Min	Max	Min	Max
A	1.35	1.75	0.053	0.069
A ₁	0.10	0.20	0.004	0.008
B	0.35	0.45	0.014	0.018
c	0.18	0.23	0.007	0.009
D-8	4.69	5.00	0.185	0.196
D-14	8.55	8.75	0.336	0.344
D-16	9.80	10.00	0.385	0.393
E	3.50	4.05	0.140	0.160
E ₁	5.70	6.30	0.224	0.248
e	1.27 BSC		0.050 BSC	
L	0.60	0.80	0.024	0.031
⊕	0°	8°	0°	8°

L	0.13	0.25	0.005	0.010
S	0.44	0.55	0.017	0.022
⊕	0°	8°	0°	8°

Ceramic DIP, 8-14 Leads

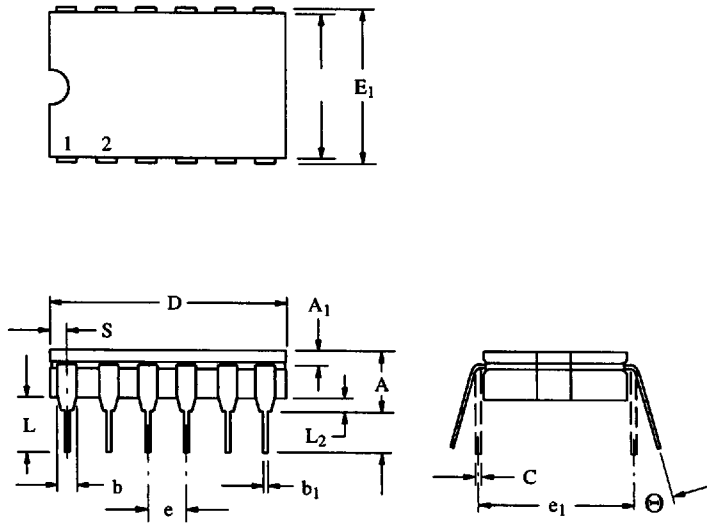

Dim	Millimeters		Inches	
	Min	Max	Min	Max
A	4.06	5.08	0.160	0.200
A ₁	1.27	2.16	0.050	0.085
b	1.14	1.65	0.045	0.065
b ₁	0.38	0.51	0.015	0.020
C	0.20	0.30	0.008	0.012
D-8	9.40	10.16	0.370	0.400
D-14	19.05	19.56	0.750	0.770
E	6.60	7.62	0.260	0.300
E ₁	7.62	8.26	0.300	0.325
e	2.54 BSC		0.100 BSC	
e ₁	7.62 BSC		0.300 BSC	
L	3.81	5.08	0.150	0.200
L ₁	3.18	3.81	0.125	0.150
L ₂	0.51	1.14	0.020	0.045
S-8	0.64	1.52	0.025	0.060
S-14	1.65	2.41	0.065	0.095
S-16	0.38	1.14	0.015	0.045
Θ	0°	15°	0°	15°

PLCC-20

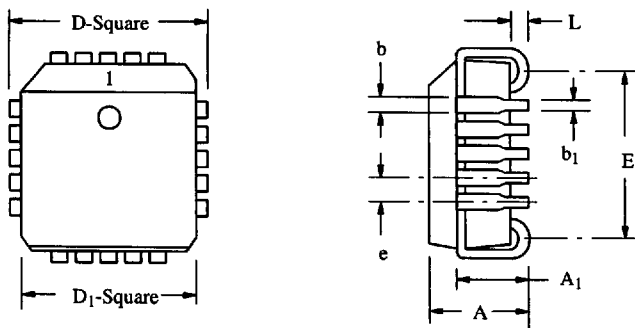

Dim	Millimeters		Inches	
	Min	Max	Min	Max
A	4.20	4.57	0.165	0.180
A ₁	2.29	3.04	0.090	0.120
b	0.66	0.81	0.026	0.032
b ₁	0.33	0.55	0.013	0.021
D	9.78	10.03	0.385	0.395
D ₁	8.89	9.04	0.350	0.356
E	9.78	10.03	0.385	0.395
e	1.27 BSC		0.050 BSC	
L	0.51	-	0.020	-