

## Rochester Electronics Manufactured Components

Rochester branded components are manufactured using either die/wafers purchased from the original suppliers or Rochester wafers recreated from the original IP. All recreations are done with the approval of the OCM.

Parts are tested using original factory test programs or Rochester developed test solutions to guarantee product meets or exceed the OCM data sheet.

## Quality Overview

- ISO-9001
- AS9120 certification
- Qualified Manufacturers List (QML) MIL-PRF-35835
  - Class Q Military
  - Class V Space Level
- Qualified Suppliers List of Distributors (QSLD)
  - Rochester is a critical supplier to DLA and meets all industry and DLA standards.

Rochester Electronics, LLC is committed to supplying products that satisfy customer expectations for quality and are equal to those originally supplied by industry manufacturers.

The original manufacturer's datasheet accompanying this document reflects the performance and specifications of the Rochester manufactured version of this device. Rochester Electronics guarantees the performance of its semiconductor products to the original OEM specifications. 'Typical' values are for reference purposes only. Certain minimum or maximum ratings may be based on product characterization, design, simulation, or sample testing.



# LP2950\*/2951

## 100mA Low-Dropout Voltage Regulator

### General Description

The LP2950 and LP2951 are micropower voltage regulators with very low dropout voltage (typically 40mV at light loads and 380mV at 100mA), and very low quiescent current (75A typical). The quiescent current of the LP2950 /LP2951 increases only slightly in dropout, thus prolonging battery life. This feature, among others, makes the LP2950 and LP2951 ideally suited for use in battery-powered systems.

Available in a 3-pin TO-92 package, the LP2950 is pin-compatible with the older 5V regulators. Additional system functions, such as programmable output voltage and logic-controlled shutdown, are available in the 8-pin DIP and 8-pin SOIC versions of the LP2951.

Data sheets and support documentation can be found on Micrel's web site at: [www.micrel.com](http://www.micrel.com).

### Features

- High accuracy 5V, guaranteed 100mA output
- Extremely low quiescent current
- Low-dropout voltage
- Extremely tight load and line regulation
- Very low temperature coefficient
- Use as regulator or reference
- Needs only 1µF for stability

### LP2951 Versions Only

- Current and thermal limiting
- Error flag warns of output dropout
- Logic-controlled electronic shutdown
- Output programmable from 1.24 to 29V

### Applications

- Automotive electronics
- Voltage reference
- Avionics

### Block Diagram

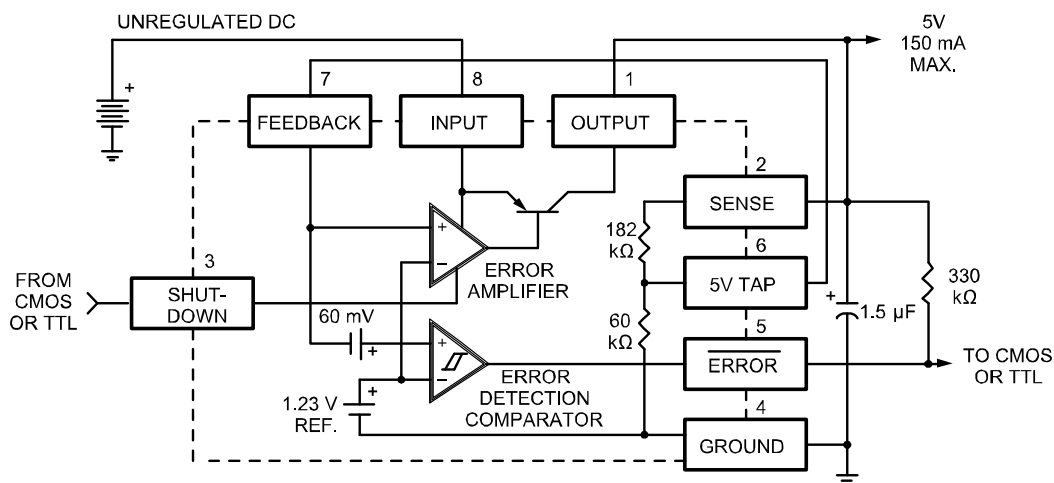

LP2950 and LP2951 Block Diagram  
(Pin Numbers Refer to LP2951)

\* LP2950 Discontinuance September 2007.

Additional features available with the LP2951 also include an error flag output that warns of a low output voltage, which is often due to failing batteries on the input. This may also be used as a power-on reset. A logic-compatible shutdown input is also available which enables the regulator to be switched on and off. This part may also be pin-strapped for a 5V output, or programmed from 1.24V to 29V with the use of two external resistors.

The LP2950 is available as either a -02 or -03 version. The -02 and -03 versions are guaranteed for junction

temperatures from  $-40^{\circ}\text{C}$  to  $+125^{\circ}\text{C}$ ; the -02 version has a tighter output and reference voltage specification range over temperature. The LP2951 is available as an -02 or -03 version.

The LP2950 and LP2951 have a tight initial tolerance (0.5% typical), a very low output voltage temperature coefficient which allows use as a low-power voltage reference, and extremely good load and line regulation (0.05% typical). This greatly reduces the error in the overall circuit, and is the result of careful design techniques and process control.

## Ordering Information

Part Number	Voltage	Accuracy	Junction Temperature Range	Package	Lead Finish
LP2950-02BZ*	5.0V	0.5%	$-40^{\circ}$ to $+125^{\circ}\text{C}$	3-Pin TO-92 Plastic	Standard
LP2950-03BZ*	5.0V	1.0%	$-40^{\circ}$ to $+125^{\circ}\text{C}$	3-Pin TO-92 Plastic	Standard
LP2951-02BM	5.0V	0.5%	$-40^{\circ}$ to $+125^{\circ}\text{C}$	8-Pin SOIC	Standard
LP2951-03BM	5.0V	1.0%	$-40^{\circ}$ to $+125^{\circ}\text{C}$	8-Pin SOIC	Standard
LP2951-02BN	5.0V	0.5%	$-40^{\circ}$ to $+125^{\circ}\text{C}$	8-Pin Plastic DIP	Standard
LP2951-03BN**	5.0V	1.0%	$-40^{\circ}$ to $+125^{\circ}\text{C}$	8-Pin Plastic DIP	Standard
LP2951-02YM	5.0V	0.5%	$-40^{\circ}$ to $+125^{\circ}\text{C}$	8-Pin SOIC	Pb-Free
LP2951-03YM	5.0V	1.0%	$-40^{\circ}$ to $+125^{\circ}\text{C}$	8-Pin SOIC	Pb-Free
LP2951-02YN	5.0V	0.5%	$-40^{\circ}$ to $+125^{\circ}\text{C}$	8-Pin Plastic DIP	Pb-Free

### Note:

\* TO-92 Package discontinuance notification issued September 2007. End-of-life-buy offer thru December 31, 2007. Contact factory for additional information.

\*\* Contact factory for Pb-Free version.

## Pin Configuration

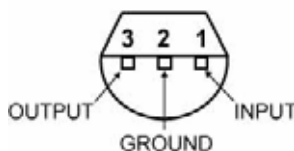

TO-92 (Z)  
(Bottom View)

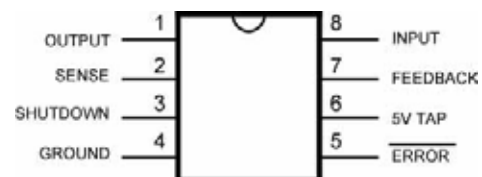

DIP (N) and SOIC (M)

See MIC2950 for a part with: 1) higher output (150mA), 2) transient protection (60V), and 3) reverse input protection to  $-20\text{V}$ .

## Absolute Maximum Ratings<sup>(1)</sup>

If Military/Aerospace specified devices are required, contact your local Micrel representative/distributor for availability and specifications.

Power Dissipation ..... Internally Limited  
 Lead Temperature (soldering, 5 sec.) ..... 260°C  
 Storage Temperature ..... -65°C to +150°C  
 Operating Junction Temperature Range<sup>(8)</sup>  
   LP2950, LP2951 ..... -40°C to +125°C  
 Input Supply Voltage ..... -0.3 to +30V  
 Feedback Input Voltage<sup>(9, 10)</sup> ..... -1.5 to +30V  
 Shutdown Input Voltage<sup>(9)</sup> ..... -0.3 to +30V  
 Error Comparator Output Voltage<sup>(9)</sup> ..... -0.3 to +30V  
 ESD Rating is to be determined

## Electrical Characteristics<sup>(1)</sup>

T<sub>A</sub> = 25°C except as noted.

Parameter	Condition	Min	Typ	Max	Units
Output Voltage T <sub>J</sub> = 25°C	LP295x-02 (±0.5%)	4.975	5.000	5.025	V
	LP295x-03 (±1%)	4.950	5.000	5.050	V
	LP2951-4.8 (±1%)	4.802	4.850	4.899	V
Output Voltage -25°C ≤ T <sub>J</sub> ≤ +85°C	LP295x-02 (±0.5%)	4.950		5.050	V
	LP295x-03 (±1%)	4.925		5.075	V
	LP2951-4.8 (±1%)	4.777		4.872	V
Output Voltage Over Full Temperature Range -40°C to +125°C	LP295x-02 (±0.5%)	<b>4.940</b>		<b>5.060</b>	V
	LP295x-03 (±1%)	<b>4.900</b>		<b>5.100</b>	V
	LP2951-4.8 (±1%)	<b>4.753</b>		<b>4.947</b>	V
Output Voltage Over Load Variation	LP295x-02 (±0.5%), 100μA ≤ I <sub>L</sub> ≤ 100mA, T <sub>J</sub> ≤ T <sub>J(max)</sub>	<b>4.930</b>		<b>5.070</b>	V
	LP295x-03 (±1%), 100μA ≤ I <sub>L</sub> ≤ 100mA, T <sub>J</sub> ≤ T <sub>J(max)</sub>	<b>4.880</b>		<b>5.120</b>	V
	LP2951-4.8 (±1%), 100μA ≤ I <sub>L</sub> ≤ 100mA, T <sub>J</sub> ≤ T <sub>J(max)</sub>	<b>4.733</b>		<b>4.967</b>	V
Output Voltage Temperature Coefficient	LP295x-02 (±0.5%), <b>Note 12</b>		<b>20</b>	<b>100</b>	ppm/°C
	LP295x-03 (±1%), <b>Note 12</b>		<b>50</b>	<b>150</b>	ppm/°C
	LP2951-4.8 (±1%), <b>Note 12</b>		<b>50</b>	<b>150</b>	ppm/°C
Line Regulation	LP295x-02 (±0.5%), <b>Notes 14, 15</b>		0.03	0.10 <b>0.20</b>	% %
	LP295x-03 (±1%), <b>Notes 14, 15</b>		0.04	0.20 <b>0.40</b>	% %
	LP2951-4.8 (±1%), <b>Notes 14, 15</b>		0.04	0.20 <b>0.40</b>	% %
Load Regulation	LP295x-02 (±0.5%), <b>Note 14</b> , 100μA ≤ I <sub>L</sub> ≤ 100mA		0.04	0.10 <b>0.20</b>	% %
	LP295x-03 (±1%), <b>Note 14</b> , 100μA ≤ I <sub>L</sub> ≤ 100mA		0.10	0.20 <b>0.30</b>	% %
	LP2951-4.8 (±1%), <b>Note 14</b> , 100μA ≤ I <sub>L</sub> ≤ 100mA		0.10	0.20 <b>0.30</b>	% %

Parameter	Condition	Min	Typ	Max	Units
Dropout Voltage	<b>Note 5</b> , $I_L = 100\mu\text{A}$		50	80 <b>150</b>	mV mV
	<b>Note 5</b> , $I_L = 100\text{mA}$		380	450 <b>600</b>	mV mV
Ground Current	$I_L = 100\mu\text{A}$		100	150 <b>200</b>	$\mu\text{A}$ $\mu\text{A}$
	$I_L = 100\text{mA}$		8	12 <b>14</b>	mA mA
Dropout Current	$V_{IN} = 4.5\text{V}$ , $I_L = 100\mu\text{A}$		180	250 <b>310</b>	$\mu\text{A}$ $\mu\text{A}$
Current Limit	$V_{OUT} = 0\text{V}$		160	220 <b>220</b>	mA mA
Thermal Regulation	<b>Note 13</b>		0.05	0.20	%/W
Output Noise	10Hz to 100kHz, $C_L = 1\mu\text{F}$		430		$\mu\text{V}_{\text{RMS}}$
	10Hz to 100kHz, $C_L = 200\mu\text{F}$		160		$\mu\text{V}_{\text{RMS}}$
	10Hz to 100kHz, $C_L = 3.3\mu\text{F}$ , 0.01 $\mu\text{F}$ bypass Feedback to Output		100		$\mu\text{V}_{\text{RMS}}$
Reference Voltage	LP295x-02 ( $\pm 0.5\%$ )	1.220 <b>1.200</b>	1.235	1.250 <b>1.260</b>	V V
	LP295x-03 ( $\pm 1\%$ )	1.210 <b>1.200</b>	1.235	1.260 <b>1.270</b>	V V
	LP2951-4.8 ( $\pm 1\%$ )	1.210 <b>1.200</b>	1.235	1.260 <b>1.270</b>	V V
Reference Voltage	LP295x-02 ( $\pm 0.5\%$ ), <b>Note 7</b>	<b>1.190</b>		<b>1.270</b>	V
	LP295x-03 ( $\pm 1\%$ ), <b>Note 7</b>	<b>1.185</b>		<b>1.285</b>	V
	LP2951-4.8 ( $\pm 1\%$ ), <b>Note 7</b>	<b>1.185</b>		<b>1.285</b>	V
Feedback Bias Current			20	40 <b>60</b>	nA nA
Reference Voltage	LP295x-02 ( $\pm 0.5\%$ ), <b>Note 12</b>		20		ppm/ $^{\circ}\text{C}$
	LP295x-03 ( $\pm 1\%$ ), <b>Note 12</b>		50		ppm/ $^{\circ}\text{C}$
	LP2951-4.8 ( $\pm 1\%$ ), <b>Note 12</b>		50		ppm/ $^{\circ}\text{C}$
Feedback Bias Current Temperature Coefficient			0.1		nA/ $^{\circ}\text{C}$
Output Leakage Current	$V_{OH} = 30\text{V}$		0.01	1.00 <b>2.00</b>	$\mu\text{A}$ $\mu\text{A}$
Output Low Voltage (Flag)	$V_{IN} = 4.5\text{V}$ , $I_{OL} = 200\mu\text{A}$		150	250 <b>400</b>	mV mV
Upper Threshold Voltage	<b>Note 6</b>	40 <b>25</b>	60		mV mV
Lower Threshold Voltage	<b>Note 6</b>		75	95 <b>140</b>	mV mV
Hysteresis	<b>Note 6</b>		15		mV

Parameter	Condition	Min	Typ	Max	Units
Input Logic Voltage	LP295x-02 ( $\pm 0.5\%$ ) Low High	<b>2.0</b>	1.3	<b>0.7</b>	V
					V
					V
	LP295x-03 ( $\pm 1\%$ ) Low High	<b>2.0</b>	1.3	<b>0.7</b>	V
					V
					V
	LP2951-4.8 ( $\pm 1\%$ ) Low High	<b>2.0</b>	1.3	<b>0.7</b>	V
					V
					V
Shutdown Input Current	$V_{\text{SHUTDOWN}} = 2.4\text{V}$		30	50 <b>100</b>	$\mu\text{A}$ $\mu\text{A}$
	$V_{\text{SHUTDOWN}} = 30\text{V}$		450	600 <b>700</b>	$\mu\text{A}$ $\mu\text{A}$
Regulator Output Current in Shutdown	<b>Note 11</b>		3	10 <b>20</b>	$\mu\text{A}$ $\mu\text{A}$

**Notes:**

- Boldface limits apply at temperature extremes.
- Unless otherwise specified all limits guaranteed for  $T_J = 25^\circ\text{C}$ ,  $V_{\text{IN}} = 6\text{V}$ ,  $I_L = 100\mu\text{A}$  and  $C_L = 1\mu\text{F}$ . Additional conditions for the 8-pin versions are Feedback tied to 5V Tap and Output tied to Output Sense ( $V_{\text{OUT}} = 5\text{V}$ ) and  $V_{\text{SHUTDOWN}} \leq 0.8\text{V}$ .
- Guaranteed and 100% production tested.
- Guaranteed but not 100% production tested. These limits are not used to calculate outgoing AQL levels.
- Dropout voltage is defined as the input to output differential at which the output voltage drops 100mV below its nominal value measured at 1V differential. At very low values of programmed output voltage, the minimum input supply voltage of 2V (2.3V over temperature) must be taken into account.
- Comparator thresholds are expressed in terms of a voltage differential at the Feedback terminal below the nominal reference voltage measured at 6V input. To express these thresholds in terms of output voltage change, multiply by the error amplifier gain  $= V_{\text{OUT}}/V_{\text{REF}} = (R1 + R2)/R2$ . For example, at a programmed output voltage of 5V, the Error output is guaranteed to go low when the output drops by  $95\text{mV} \times 5\text{V}/1.235\text{V} = 384\text{mV}$ . Thresholds remain constant as a percent of  $V_{\text{OUT}}$  as  $V_{\text{OUT}}$  is varied, with the dropout warning occurring at typically 5% below nominal, 7.5% guaranteed.
- $V_{\text{REF}} \leq V_{\text{OUT}} \leq (V_{\text{IN}} - 1\text{V})$ ,  $2.3\text{V} \leq V_{\text{IN}} \leq 30\text{V}$ ,  $100\mu\text{A} < I_L \leq 100\text{mA}$ ,  $T_J \leq T_{\text{JMAX}}$ .
- The junction-to-ambient thermal resistance of the TO-92 package is  $180^\circ\text{C/W}$  with 0.4" leads and  $160^\circ\text{C/W}$  with 0.25" leads to a PC board. The thermal resistance of the 8-pin DIP package is  $105^\circ\text{C/W}$  junction-to-ambient when soldered directly to a PC board. Junction-to-ambient thermal resistance for the SOIC (M) package is  $160^\circ\text{C/W}$ .
- May exceed input supply voltage.
- When used in dual-supply systems where the output terminal sees loads returned to a negative supply, the output voltage should be diode-clamped to ground.
- $V_{\text{SHUTDOWN}} \geq 2\text{V}$ ,  $V_{\text{IN}} \leq 30\text{V}$ ,  $V_{\text{OUT}} = 0$ , with Feedback pin tied to 5V Tap.
- Output or reference voltage temperature coefficient is defined as the worst case voltage change divided by the total temperature range.
- Thermal regulation is defined as the change in output voltage at a time T after a change in power dissipation is applied, excluding load or line regulation effects. Specifications are for a 50mA load pulse at  $V_{\text{IN}} = 30\text{V}$  (1.25W pulse) for  $t = 10\text{ms}$ .
- Regulation is measured at constant junction temperature, using pulse testing with a low duty cycle. Changes in output voltage due to heating effects are covered in the specification for thermal regulation.
- Line regulation for the LP2951 is tested at  $150^\circ\text{C}$  for  $I_L = 1\text{mA}$ . For  $I_L = 100\mu\text{A}$  and  $T_J = 125^\circ\text{C}$ , line regulation is guaranteed by design to 0.2%. See Typical Performance Characteristics for line regulation versus temperature and load current.

## Typical Characteristics

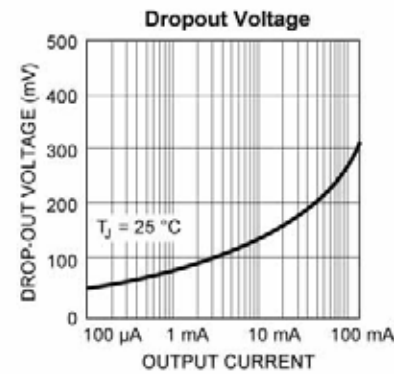
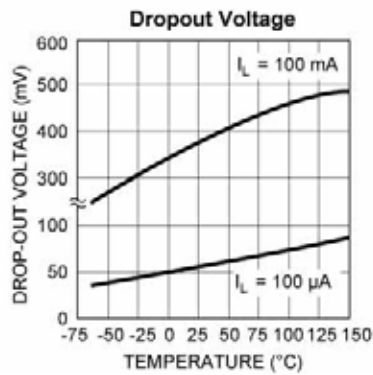
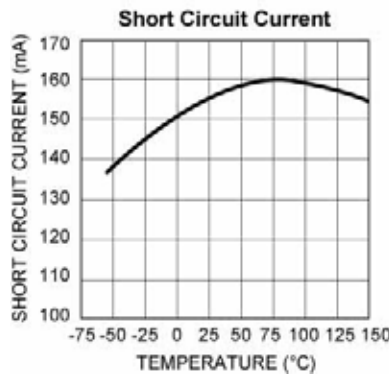
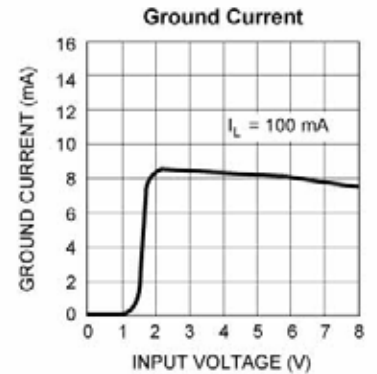
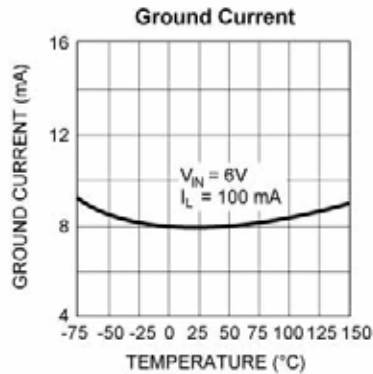
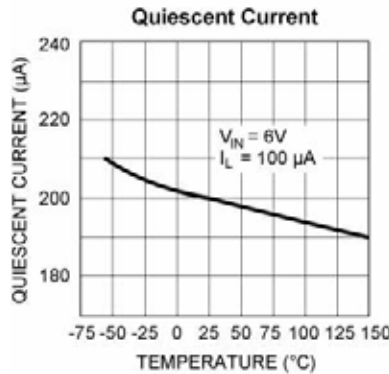
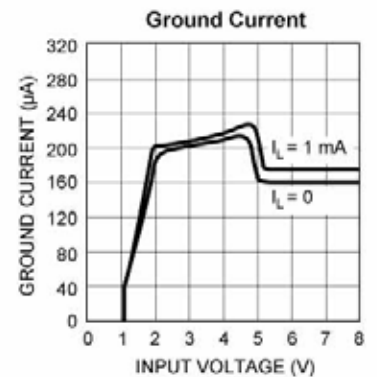
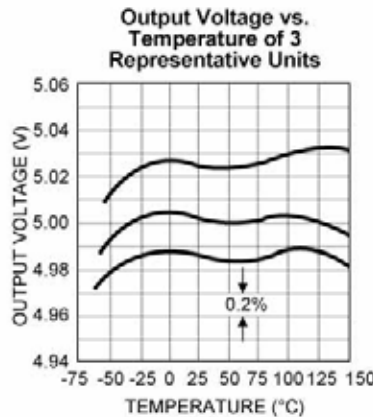
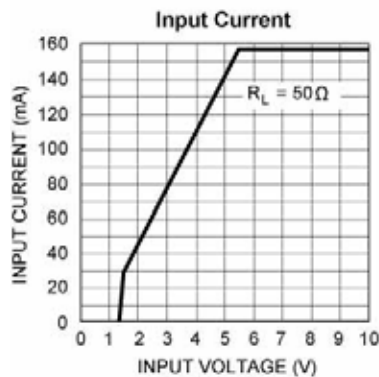
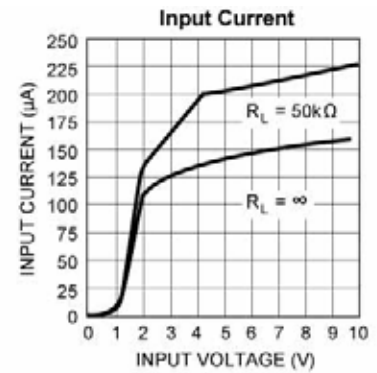
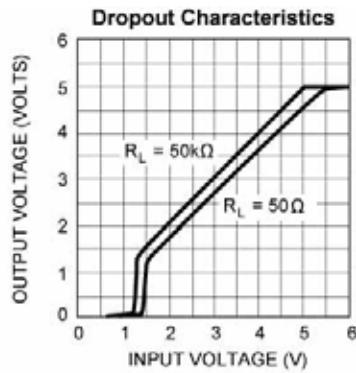
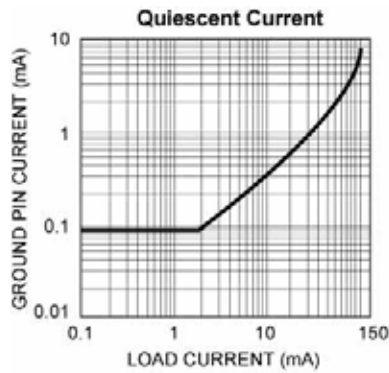

Typical Characteristics (continued)

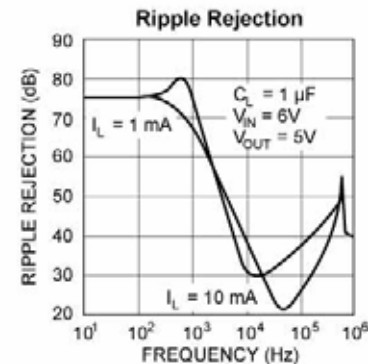
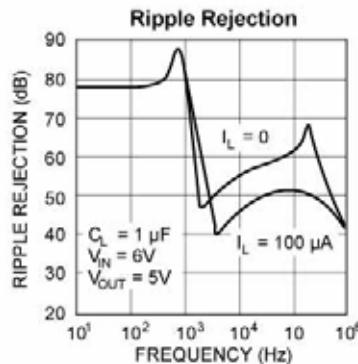
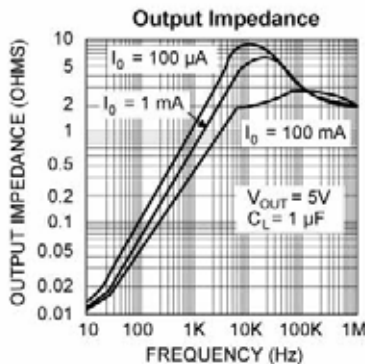
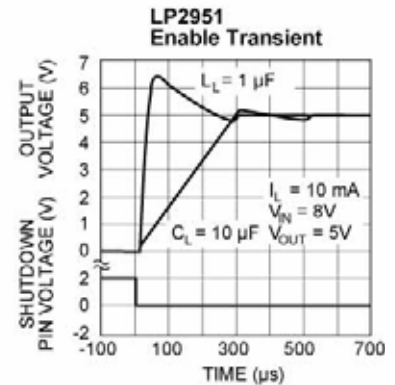
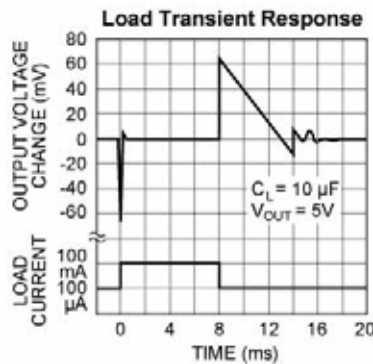
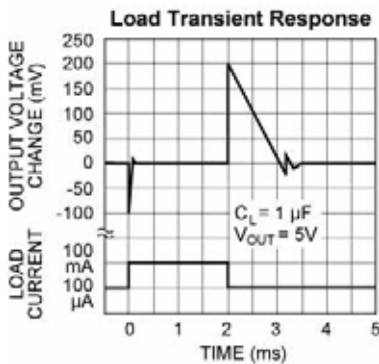
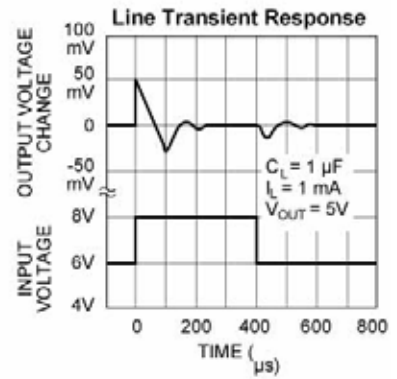
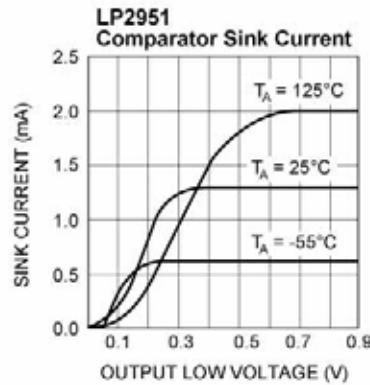
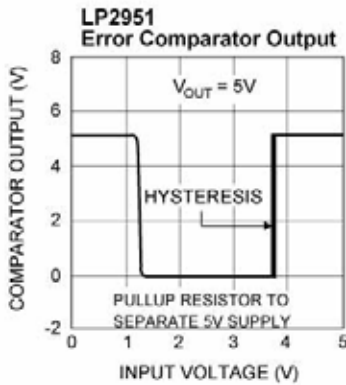
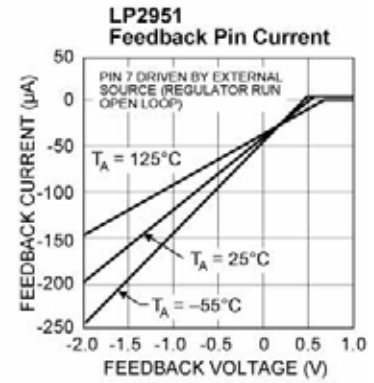
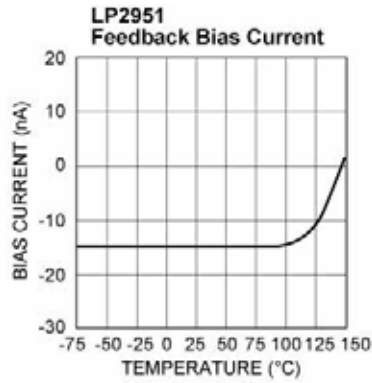
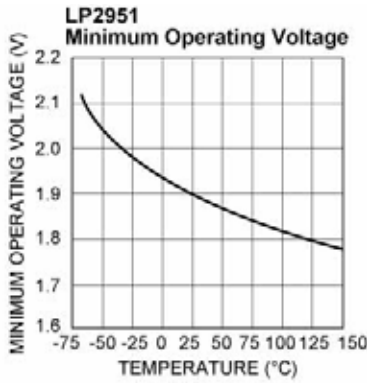



Typical Characteristics (continued)

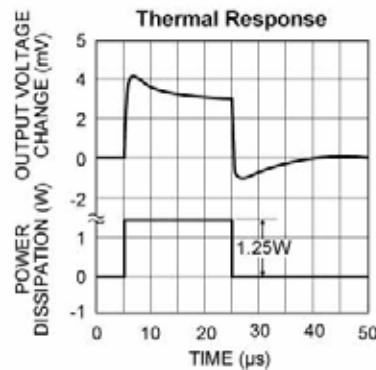
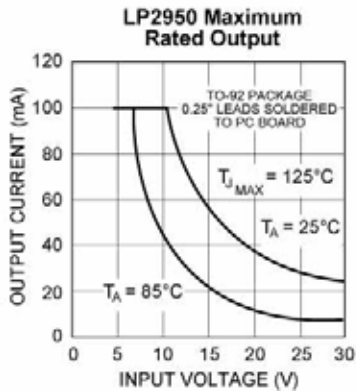
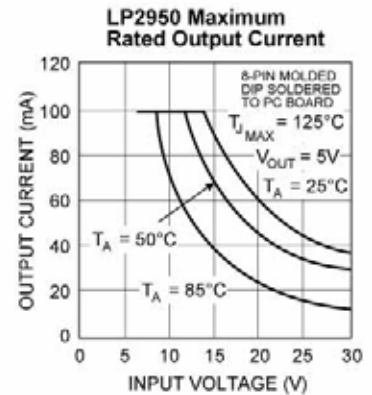
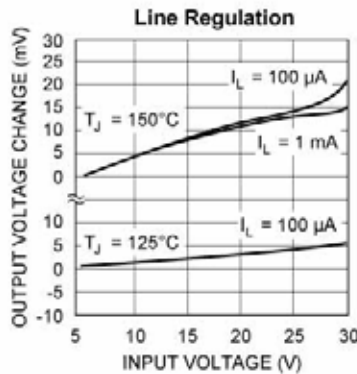
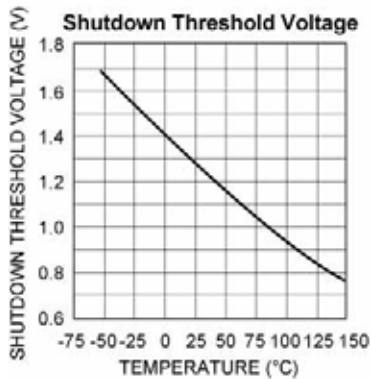
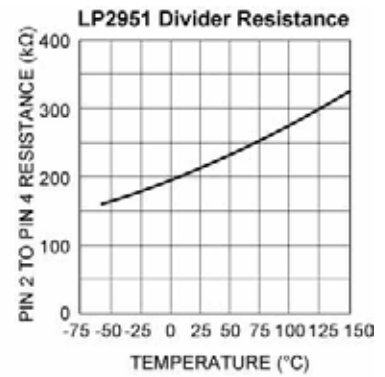
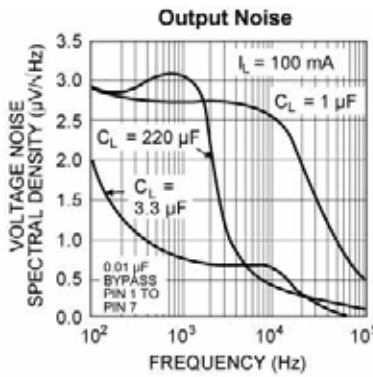
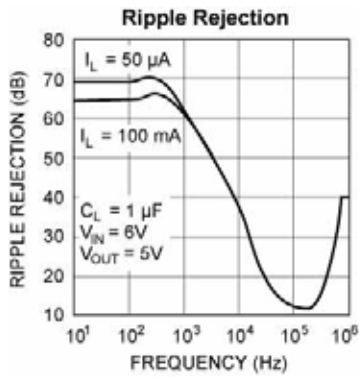

## Application Information

### External Capacitors

A 1.0 $\mu$ F (or greater) capacitor is required between the LP2950/LP2951 output and ground to prevent oscillations due to instability. Most types of tantalum or aluminum electrolytics will be adequate; film types will work, but are costly and therefore not recommended. Many aluminum electrolytics have electrolytes that freeze at about  $-30^{\circ}\text{C}$ , so solid tantalum capacitors are recommended for operation below  $-25^{\circ}\text{C}$ . The important parameters of the capacitor are an effective series resistance of about 5 or less and a resonant frequency above 500kHz. The value of this capacitor may be increased without limit.

At lower values of output current, less output capacitance is required for output stability. The capacitor can be reduced to 0.33 $\mu$ F for current below 10mA or 0.1 $\mu$ F for currents below 1mA. Using the 8-pin versions at voltages below 5V runs the error amplifier at lower gains so that more output capacitance is needed. For the worst-case situation of a 100mA load at 1.23V output (Output shorted to Feedback) a 3.3 $\mu$ F (or greater) capacitor should be used.

The LP2950 will remain stable and in regulation with no load in addition to the internal voltage divider, unlike many other voltage regulators. This is especially important in CMOS RAM keep-alive applications. When setting the output voltage of the LP2951 version with external resistors, a minimum load of 1 $\mu$ A is recommended.

A 0.1 $\mu$ F capacitor should be placed from the LP2950/LP2951 input to ground if there is more than 10 inches of wire between the input and the AC filter capacitor or if a battery is used as the input.

Stray capacitance to the LP2951 Feedback terminal (pin 7) can cause instability. This may especially be a problem when using high value external resistors to set the output voltage. Adding a 100pF capacitor between Output and Feedback and increasing the output capacitor to at least 3.3 $\mu$ F will remedy this.

### Error Detection Comparator Output

A logic low output will be produced by the comparator whenever the LP2951 output falls out of regulation by more than approximately 5%. This figure is the comparator's built-in offset of about 60mV divided by the 1.235V reference voltage. (Refer to the block diagram on Page 1). This trip level remains "5% below normal" regardless of the programmed output voltage of the LP2951. For example, the error flag trip level is typically 4.75V for a 5V output or 11.4V for a 12V output. The out of regulation condition may be due either to low input voltage, current limiting, or thermal limiting.

Figure 1 is a timing diagram depicting the /ERROR signal and the regulated output voltage as the LP2951 input is ramped up and down. The /ERROR signal becomes valid (low) at about 1.3V input. It goes high at about 5V input (the input voltage at which  $V_{\text{OUT}} = 4.75\text{V}$ ). Since the LP2951's dropout voltage is load-dependent (see curve in Typical Performance Characteristics), the input voltage trip point (about 5V) will vary with the load current. The output voltage trip point (approximately 4.75V) does not vary with load.

The error comparator has an open-collector output which requires an external pull-up resistor. Depending on system requirements, this resistor may be returned to the 5V output or some other supply voltage. In determining a value for this resistor, note that while the output is rated to sink 400 $\mu$ A, this sink current adds to battery drain in a low battery condition. Suggested values range from 100k to 1M $\Omega$ . The resistor is not required if this output is unused.

### Programming the Output Voltage (LP2951)

The LP2951 may be pin-strapped for 5V using its internal voltage divider by tying Pin 1 (output) to Pin 2 (SENSE) and Pin 7 (FEEDBACK) to Pin 6 (5V TAP). Alternatively, it may be programmed for any output voltage between its 1.235V reference and its 30V maximum rating. An external pair of resistors is required, as shown in Figure 2.

The complete equation for the output voltage is:

$$V_{\text{OUT}} = V_{\text{REF}} \times \left\{ 1 + \frac{R_1}{R_2} \right\} + I_{\text{FB}} R_2$$

where  $V_{\text{REF}}$  is the nominal 1.235 reference voltage and  $I_{\text{FB}}$  is the feedback pin bias current, nominally 20nA. The minimum recommended load current of 1 $\mu$ A forces an upper limit of 1.2M $\Omega$  on the value of  $R_2$ , if the regulator must work with no load (a condition often found in CMOS in standby),  $I_{\text{FB}}$  will produce a 2% typical error in  $V_{\text{OUT}}$  which may be eliminated at room temperature by trimming  $R_1$ . For better accuracy, choosing  $R_2 = 100\text{k}\Omega$  reduces this error to 0.17% while increasing the resistor program current to 12 $\mu$ A. Since the LP2951 typically draws 60 $\mu$ A at no load with Pin 2 open-circuited, this is a small price to pay.

### Reducing Output Noise

In reference applications it may be advantageous to reduce the AC noise present at the output. One method is to reduce the regulator bandwidth by increasing the size of the output capacitor. This is the only method by which noise can be reduced on the 3-pin LP2950 and is relatively inefficient, as increasing the capacitor from 1 $\mu$ F to 220 $\mu$ F only decreases the noise from 430 $\mu$ V to 160 $\mu$ Vrms for a 100kHz bandwidth at 5V output.

Noise can be reduced fourfold by a bypass capacitor across  $R_1$ , since it reduces the high frequency gain from 4 to unity. Pick:

$$C_{\text{BYPASS}} \cong \frac{1}{2\pi R_1 \bullet 200\text{Hz}}$$

or about  $0.01\mu\text{F}$ . When doing this, the output capacitor must be increased to  $3.3\mu\text{F}$  to maintain stability. These changes reduce the output noise from  $430\mu\text{V}$  to  $100\mu\text{Vrms}$  for a  $100\text{kHz}$  bandwidth at  $5\text{V}$  output. With the bypass capacitor added, noise no longer scales with output voltage so that improvements are more dramatic at higher output voltages.

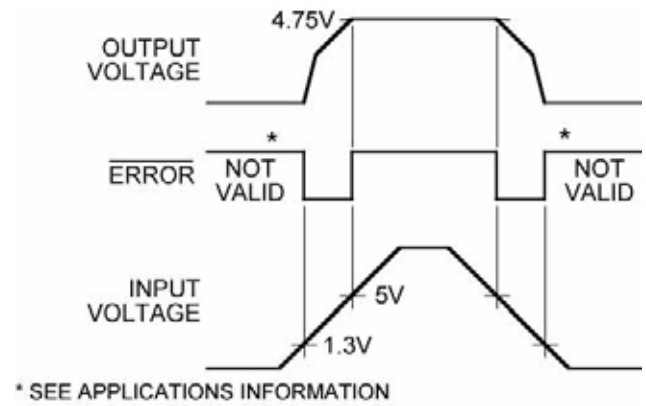

Figure 1. ERROR Output Timing

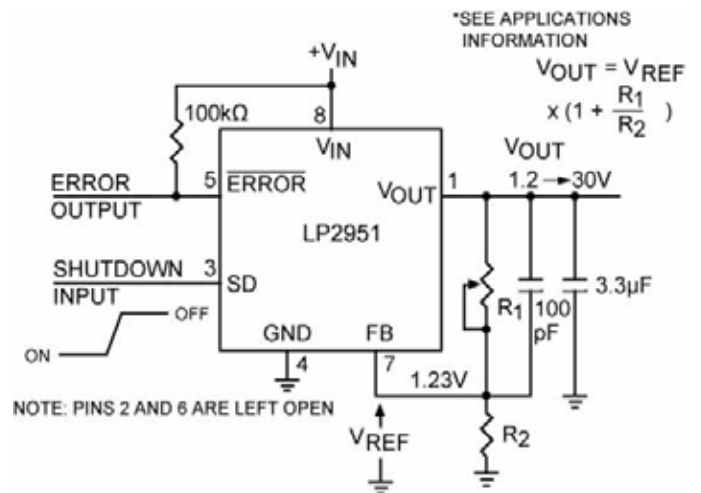
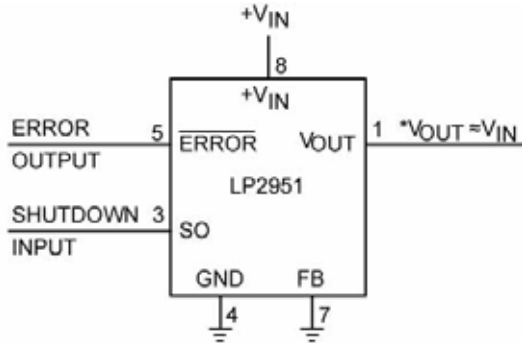

Figure 2. Adjustable Regulator

## Typical Applications



\*MINIMUM INPUT-OUTPUT VOLTAGE RANGES FROM 40mV TO 400mV, DEPENDING ON LOAD CURRENT. CURRENT LIMIT IS TYPICALLY 160mA.

**Wide Input Voltage Range Current Limiter**

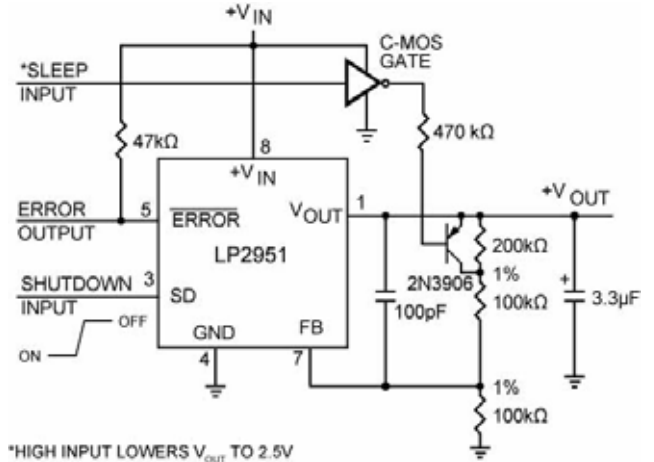

**5V Regulator with 2.5V Sleep Function**

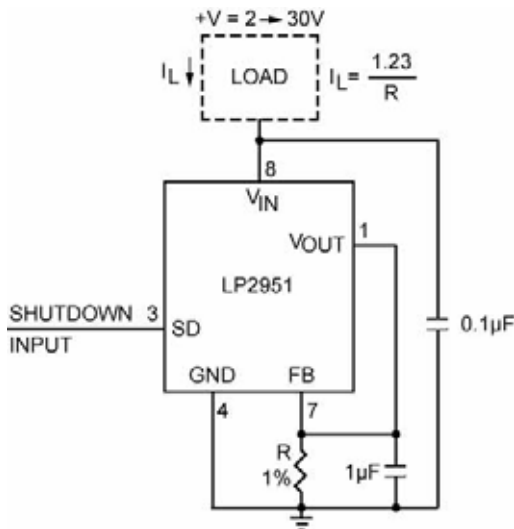

**Low Drift Current Source**

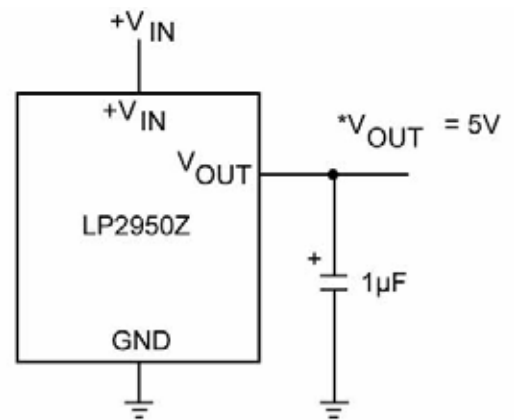

\* MINIMUM INPUT-OUTPUT VOLTAGE RANGES FROM 40mV TO 400mV, DEPENDING ON LOAD CURRENT.

**5V Current Limiter**

## Typical Applications

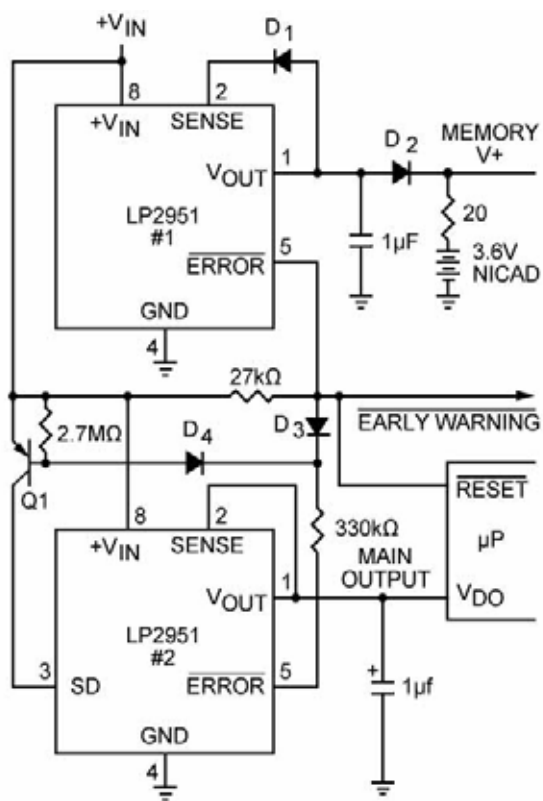

- EARLY WARNING FLAG ON LOW INPUT VOLTAGE
- MAIN OUTPUT LATCHES OFF AT LOWER INPUT VOLTAGES
- BATTERY BACKUP ON AUXILIARY OUTPUT

OPERATION: REG. #1'S  $V_{OUT}$  IS PROGRAMMED ONE DIODE DROP ABOVE 5 V. ITS ERROR FLAG BECOMES ACTIVE WHEN  $V_{IN} \leq 5.7$  V. WHEN  $V_{IN}$  DROPS BELOW 5.3 V, THE ERROR FLAG OF REG. #2 BECOMES ACTIVE AND VIA Q1 LATCHES THE MAIN OUTPUT OFF. WHEN  $V_{IN}$  AGAIN EXCEEDS 5.7 V REG. #1 IS BACK IN REGULATION AND THE EARLY WARNING SIGNAL RISES, UNLATCHING REG. #2 VIA D3.

### Regulator with Early Warning and Auxiliary Output

## Typical Applications

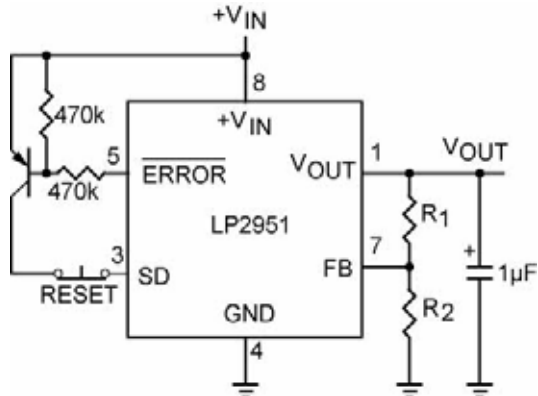

Latch Off When Error Flag Occurs

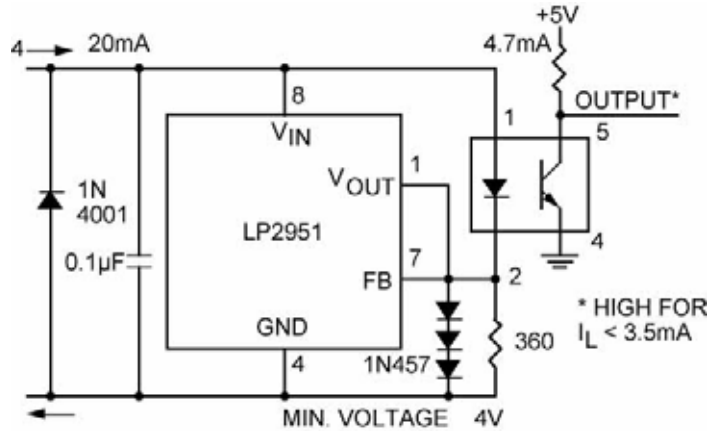

Open Circuit Detector for 4mA to 20mA Current Loop

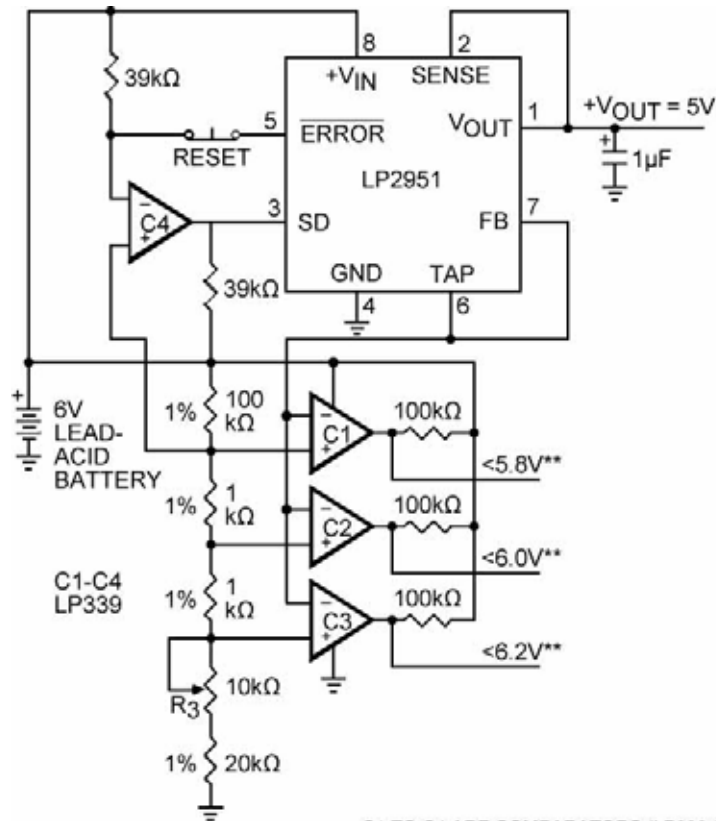

C1 TO C4 ARE COMPARATORS (LP339 OR EQUIVALENT)

\*OPTIONAL LATCH OFF WHEN DROP OUT OCCURS. ADJUST R3 FOR C2 SWITCHING WHEN  $V_{IN}$  IS 6.0V

\*\*OUTPUTS GO LOW WHEN  $V_{IN}$  DROPS BELOW DESIGNATED THRESHOLDS.

Regulator with State-of-Charge Indicator

## Typical Applications

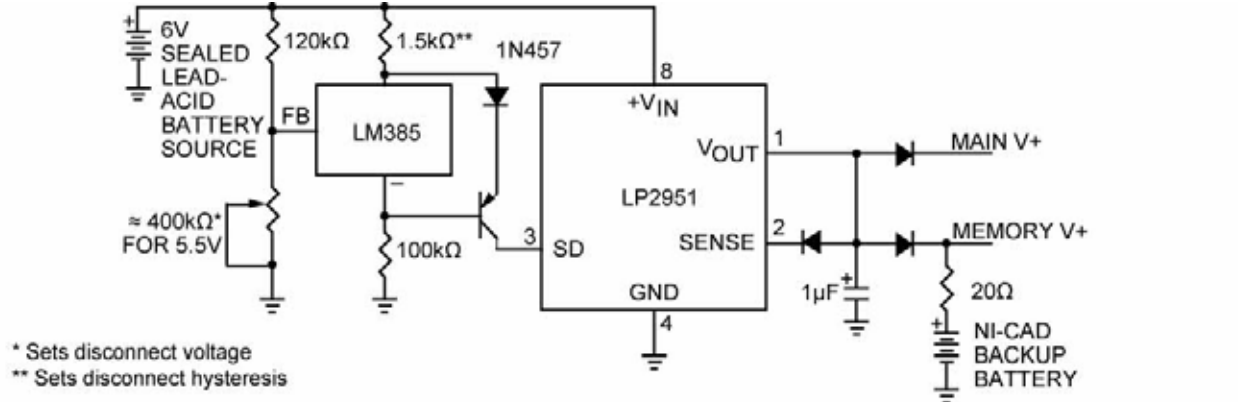

For values shown, Regulator shuts down when  $V_{IN} < 5.5\text{ V}$  and turns on again at  $6.0\text{ V}$ . Current drain in disconnected mode is  $150\mu\text{A}$ .

**Low Battery Disconnect**

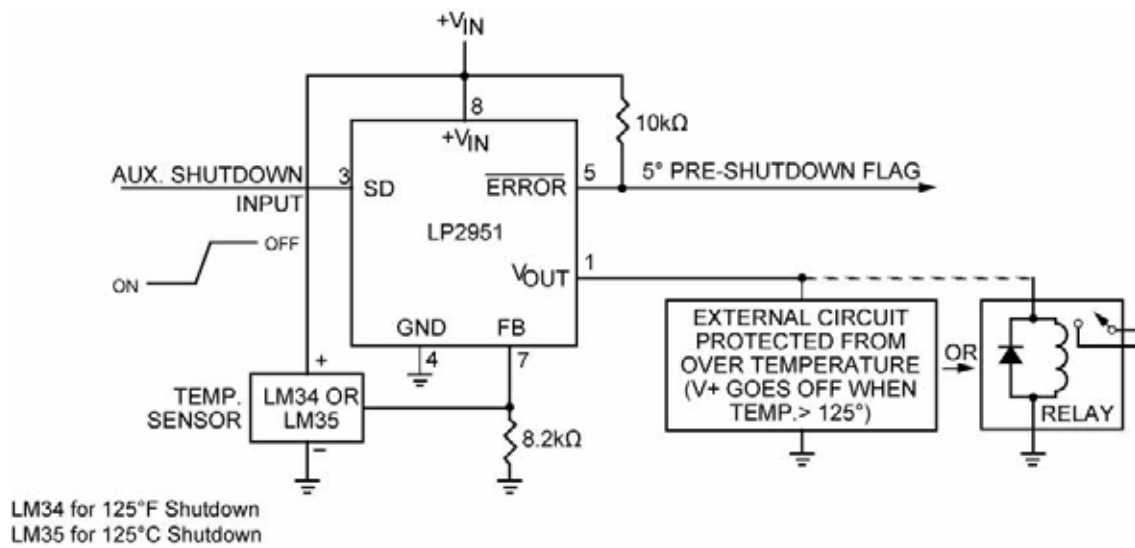

**System Over Temperature Protection Circuit**

# Schematic Diagram

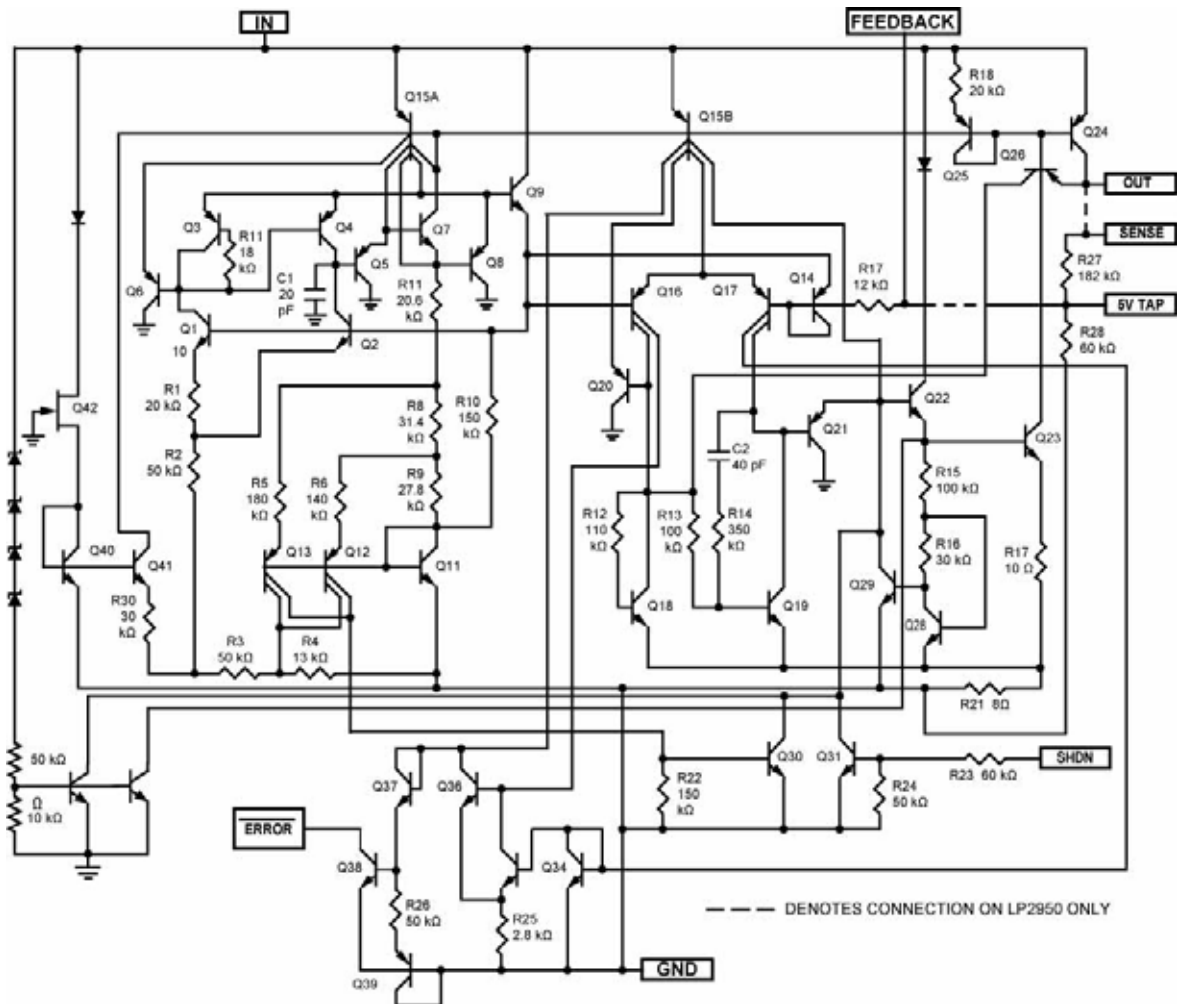



# Package Information

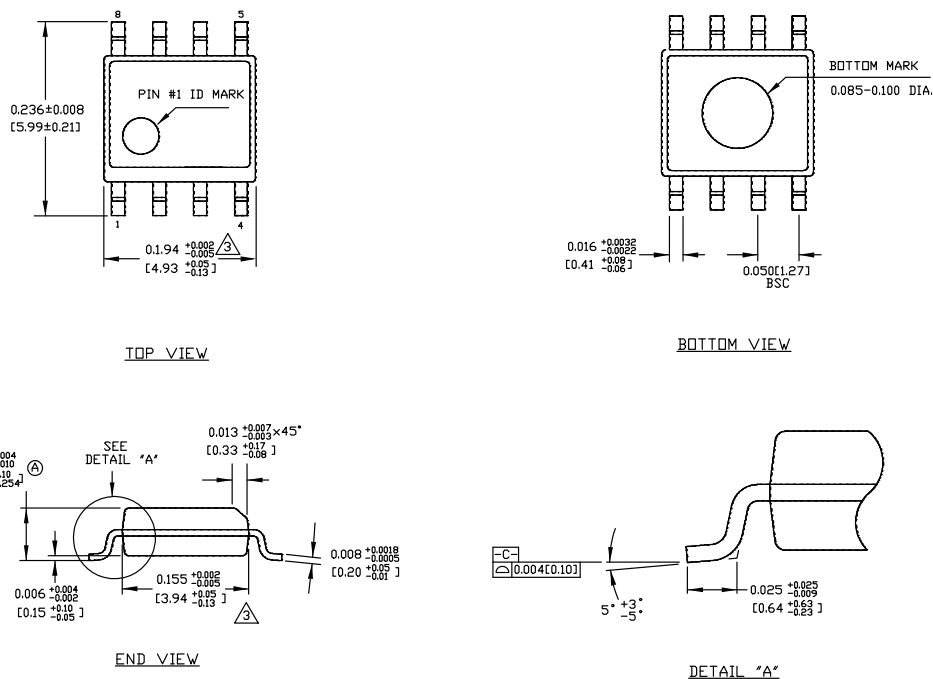

- NOTES:**
1. DIMENSIONS ARE IN INCHES(MM).
  2. CONTROLLING DIMENSION: INCHES.
- △ DIMENSION DOES NOT INCLUDE MOLD FLASH OR PROTRUSIONS, EITHER OF WHICH SHALL NOT EXCEED 0.010(0.25) PER SIDE.

## 8-Pin SOIC (M)

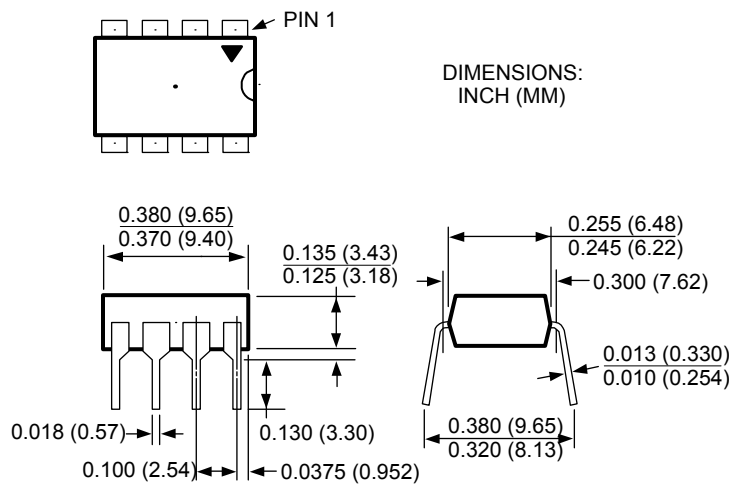

## 8-Pin Plastic DIP (N)

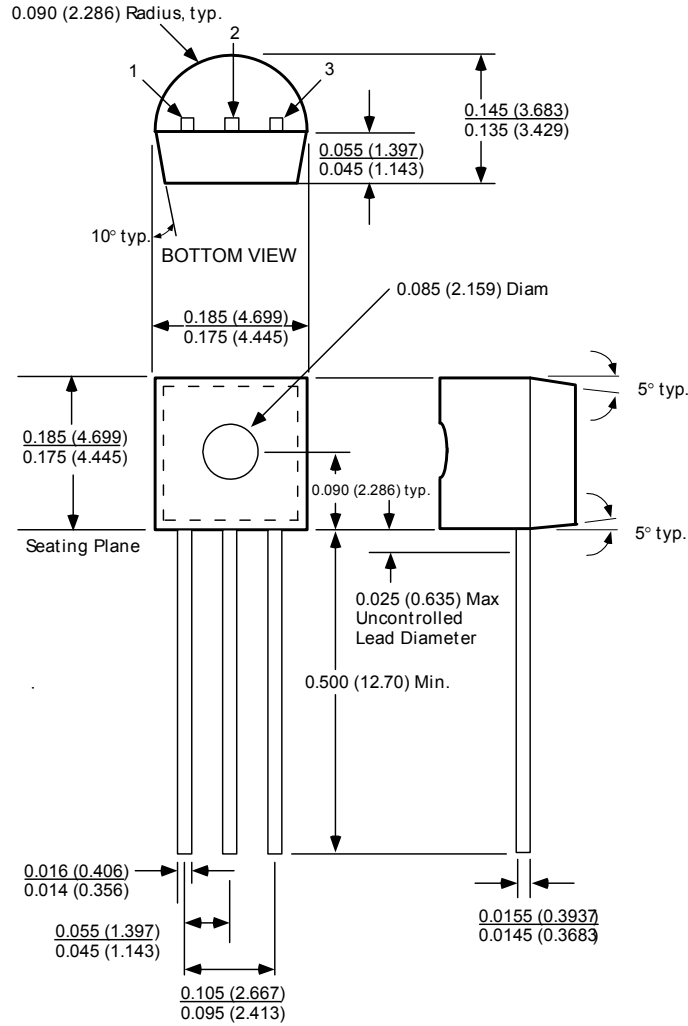

TO-92 (Z)

**MICREL, INC. 2180 FORTUNE DRIVE SAN JOSE, CA 95131 USA**  
 TEL +1 (408) 944-0800 FAX +1 (408) 474-1000 WEB <http://www.micrel.com>

The information furnished by Micrel in this data sheet is believed to be accurate and reliable. However, no responsibility is assumed by Micrel for its use. Micrel reserves the right to change circuitry and specifications at any time without notification to the customer.

Micrel Products are not designed or authorized for use as components in life support appliances, devices or systems where malfunction of a product can reasonably be expected to result in personal injury. Life support devices or systems are devices or systems that (a) are intended for surgical implant into the body or (b) support or sustain life, and whose failure to perform can be reasonably expected to result in a significant injury to the user. A Purchaser's use or sale of Micrel Products for use in life support appliances, devices or systems is a Purchaser's own risk and Purchaser agrees to fully indemnify Micrel for any damages resulting from such use or sale.

© 1999 Micrel, Incorporated.