



128Kx32 SRAM MODULE, SMD 5962-93187 & 5962-95595

FEATURES

- Access Times of 15, 17, 20, 25, 35, 45, 55ns
- MIL-STD-883 Compliant Devices Available
- Packaging
 - 66 pin, PGA Type, 1.075" square, Hermetic Ceramic HIP (Package 400)
 - 68 lead, 40mm CQFP (G4T), 3.56mm (0.140") (Package 502).
 - 68 lead, 22.4mm CQFP (G2T), 4.57mm (0.180"), (Package 509)
 - 68 lead, 22.4mm Low Profile CQFP (G1U), 3.57mm (0.140"), (Package 519)
- Organized as 128Kx32; User Configurable as 256Kx16 or 512Kx8
- Low Power Data Retention - only available in G2T package type
- Commercial, Industrial and Military Temperature Ranges
- 5 Volt Power Supply
- Low Power CMOS
- TTL Compatible Inputs and Outputs
- Built in Decoupling Caps and Multiple Ground Pins for Low Noise Operation
- Weight:
 - WS128K32-XG1UX - 5 grams typical
 - WS128K32-XG2TX - 8 grams typical
 - WS128K32-XH1X - 13 grams typical
 - WS128K32-XG4TX - 20 grams typical
- All devices are upgradeable to 512Kx32

FIG. 1 PIN CONFIGURATION FOR WS128K32N-XH1X

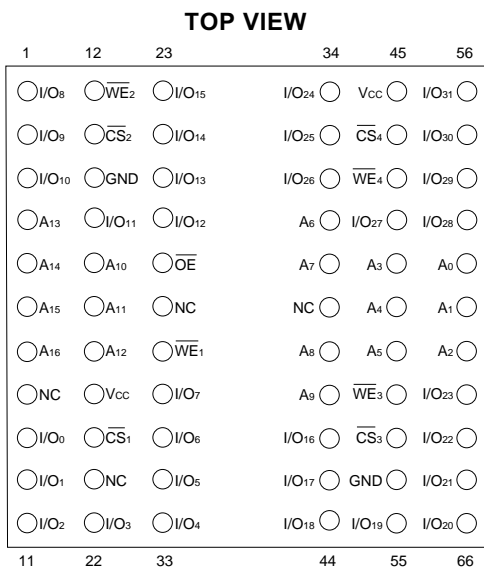

PIN DESCRIPTION

I/O ₀₋₃₁	Data Inputs/Outputs
A ₀₋₁₆	Address Inputs
\overline{WE}_{1-4}	Write Enables
\overline{CS}_{1-4}	Chip Selects
\overline{OE}	Output Enable
V _{CC}	Power Supply
GND	Ground
NC	Not Connected

BLOCK DIAGRAM

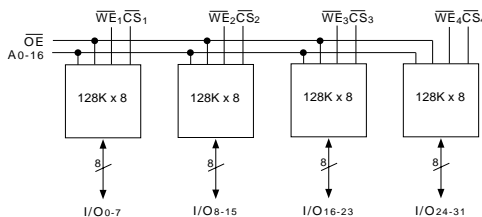



FIG. 2 PIN CONFIGURATION FOR WS128K32-XG4TX

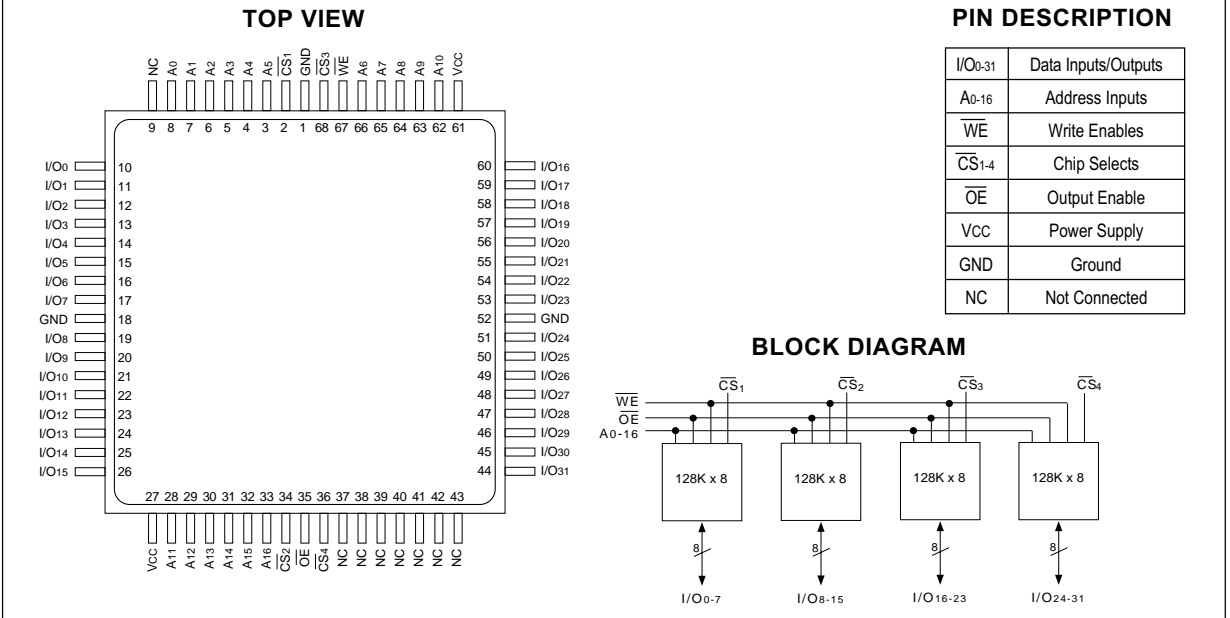
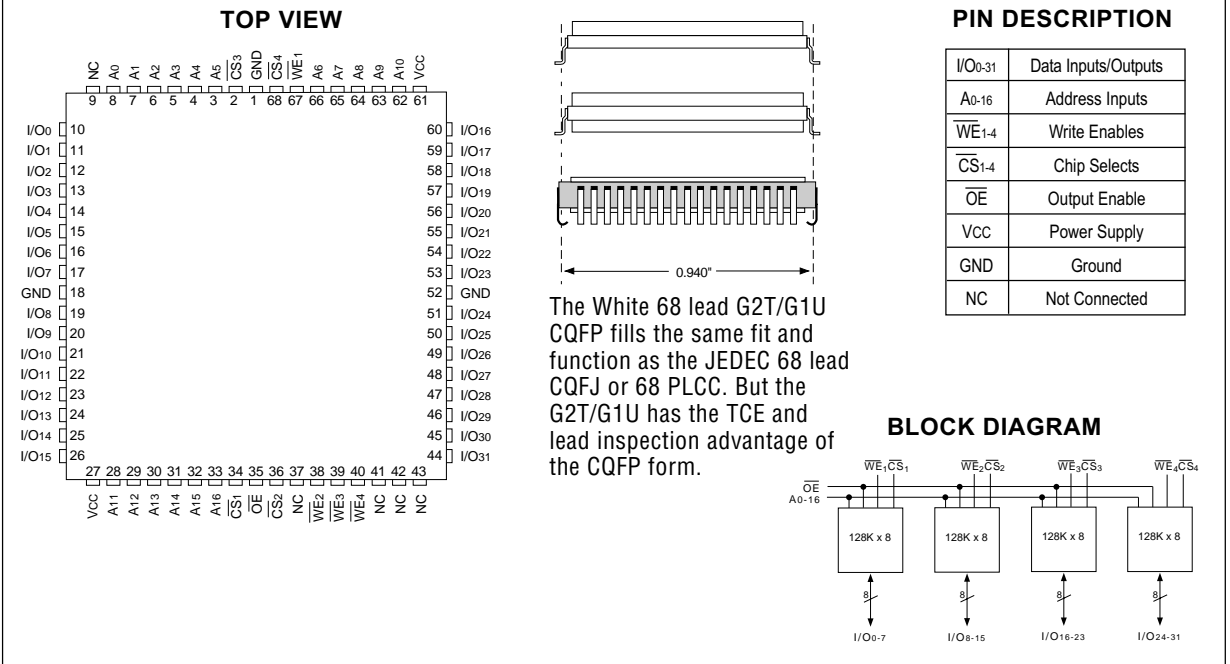

FIG. 3 PIN CONFIGURATION FOR WS128K32-XG2TX AND WS128K32-XG1UX





ABSOLUTE MAXIMUM RATINGS

Parameter	Symbol	Min	Max	Unit
Operating Temperature	T _A	-55	+125	°C
Storage Temperature	T _{STG}	-65	+150	°C
Signal Voltage Relative to GND	V _G	-0.5	V _{CC} +0.5	V
Junction Temperature	T _J		150	°C
Supply Voltage	V _{CC}	-0.5	7.0	V

RECOMMENDED OPERATING CONDITIONS

Parameter	Symbol	Min	Max	Unit
Supply Voltage	V _{CC}	4.5	5.5	V
Input High Voltage	V _{IH}	2.2	V _{CC} + 0.3	V
Input Low Voltage	V _{IL}	-0.3	+0.8	V
Operating Temp. (Mil.)	T _A	-55	+125	°C

TRUTH TABLE

\overline{CS}	\overline{OE}	\overline{WE}	Mode	Data I/O	Power
H	X	X	Standby	High Z	Standby
L	L	H	Read	Data Out	Active
L	X	L	Write	Data In	Active
L	H	H	Out Disable	High Z	Active

CAPACITANCE

(T_A = +25°C)

Parameter	Symbol	Conditions	Max	Unit
\overline{OE} capacitance	C _{OE}	V _{IN} = 0 V, f = 1.0 MHz	50	pF
\overline{WE}_{1-4} capacitance HIP (PGA) H1	C _{WE}	V _{IN} = 0 V, f = 1.0 MHz	20	pF
CQFP G4			50	
CQFP G2T			20	
G1U			20	
\overline{CS}_{1-4} capacitance	C _{CS}	V _{IN} = 0 V, f = 1.0 MHz	20	pF
Data I/O capacitance	C _{I/O}	V _{I/O} = 0 V, f = 1.0 MHz	20	pF
Address input capacitance	C _{AD}	V _{IN} = 0 V, f = 1.0 MHz	50	pF

This parameter is guaranteed by design but not tested.

DC CHARACTERISTICS

(V_{CC} = 5.0V, GND = 0V, T_A = -55°C to +125°C)

Parameter	Sym	Conditions	-15		-17		-20		-25		Units
			Min	Max	Min	Max	Min	Max	Min	Max	
Input Leakage Current	I _{LI}	V _{CC} = 5.5, V _{IN} = GND to V _{CC}		10		10		10		10	μA
Output Leakage Current	I _{LO}	\overline{CS} = V _{IH} , \overline{OE} = V _{IH} , V _{OUT} = GND to V _{CC}		10		10		10		10	μA
Operating Supply Current	I _{CC}	\overline{CS} = V _{IL} , \overline{OE} = V _{IH} , f = 5MHz, V _{CC} = 5.5		600		600		600		600	mA
Standby Current	I _{SB}	\overline{CS} = V _{IH} , \overline{OE} = V _{IH} , f = 5MHz, V _{CC} = 5.5		80		80		80		60	mA
Output Low Voltage	V _{OL}	I _{OL} = 8mA, V _{CC} = 4.5		0.4		0.4		0.4		0.4	V
Output High Voltage	V _{OH}	I _{OH} = -4.0mA, V _{CC} = 4.5	2.4		2.4		2.4		2.4		V

Parameter	Sym	Conditions	-35		-45		-55		Units
			Min	Max	Min	Max	Min	Max	
Input Leakage Current	I _{LI}	V _{CC} = 5.5, V _{IN} = GND to V _{CC}		10		10		10	μA
Output Leakage Current	I _{LO}	\overline{CS} = V _{IH} , \overline{OE} = V _{IH} , V _{OUT} = GND to V _{CC}		10		10		10	μA
Operating Supply Current	I _{CC}	\overline{CS} = V _{IL} , \overline{OE} = V _{IH} , f = 5MHz, V _{CC} = 5.5		600		600		600	mA
Standby Current	I _{SB}	\overline{CS} = V _{IH} , \overline{OE} = V _{IH} , f = 5MHz, V _{CC} = 5.5		60		60		60	mA
Output Low Voltage	V _{OL}	I _{OL} = 2.1mA, V _{CC} = 4.5		0.4		0.4		0.4	V
Output High Voltage	V _{OH}	I _{OH} = -1.0mA, V _{CC} = 4.5	2.4		2.4		2.4		V

NOTE: DC test conditions: V_{IH} = V_{CC} - 0.3V, V_{IL} = 0.3V

LOWER POWER DATA RETENTION CHARACTERISTICS (L PRODUCT ONLY)

(T_A = -55°C to +125°C), (T_A = -40°C to +85°C)

Characteristic	Sym	Conditions	Min	Typ	Max	Units
Lower Power Data Retention Voltage	V _{CC}	V _{CC} = 2.0V	2	-	-	V
Lower Power Data Retention Quiescent Current	I _{CCDR}	CS ≥ V _{CC} - 0.2V	-	1	4	mA
Chip Disable to Data Retention Time (1)	T _{CDR}	V _{IN} ≥ V _{CC} - 0.2V	0	-	-	ns
Operation Recovery Time (1)	T _R	or V _{IN} ≤ 0.2V	T _{RC}	-	-	ns

NOTE: Parameter guaranteed, but not tested.



AC CHARACTERISTICS
(VCC = 5.0V, GND = 0V, TA = -55°C to +125°C)

Parameter	Symbol	-15		-17		-20		-25		-35		-45		-55		Units
		Min	Max	Min	Max	Min	Max	Min	Max	Min	Max	Min	Max	Min	Max	
Read Cycle Time	t _{RC}	15		17		20		25		35		45		55		ns
Address Access Time	t _{AA}		15	17		20		25		35		45		55		ns
Output Hold from Address Change	t _{OH}	0		0		0		0		0		0		0		ns
Chip Select Access Time	t _{ACS}		15	17		20		25		35		45		55		ns
Output Enable to Output Valid	t _{OE}		10	10		12		15		20		25		30		ns
Chip Select to Output in Low Z	t _{CLZ} ¹	3		3		3		3		3		3		3		ns
Output Enable to Output in Low Z	t _{OLZ} ¹	0		0		0		0		0		0		0		ns
Chip Disable to Output in High Z	t _{CHZ} ¹		12	12		12		12		20		20		20		ns
Output Disable to Output in High Z	t _{OHZ} ¹		12	12		12		12		20		20		20		ns

1. This parameter is guaranteed by design but not tested.

AC CHARACTERISTICS
(VCC = 5.0V, GND = 0V, TA = -55°C to +125°C)

Parameter	Symbol	-15		-17		-20		-25		-35		-45		-55		Units
		Min	Max	Min	Max	Min	Max	Min	Max	Min	Max	Min	Max	Min	Max	
Write Cycle Time	t _{WC}	15		17		20		25		35		45		55		ns
Chip Select to End of Write	t _{CW}	14		14		15		20		25		30		45		ns
Address Valid to End of Write	t _{AW}	14		15		15		20		25		30		45		ns
Data Valid to End of Write	t _{DW}	10		10		12		15		20		25		25		ns
Write Pulse Width	t _{WP}	14		14		15		20		25		30		45		ns
Address Setup Time	t _{AS}	0		0		0		0		0		0		0		ns
Address Hold Time	t _{AH}	0		0		0		0		0		0		0		ns
Output Active from End of Write	t _{OW} ¹	3		3		3		3		4		4		4		ns
Write Enable to Output in High Z	t _{WHZ} ¹		10	10		12		15		20		25		25		ns
Data Hold Time	t _{DH}	0		0		0		0		0		0		0		ns

1. This parameter is guaranteed by design but not tested.

FIG. 4
AC TEST CIRCUIT

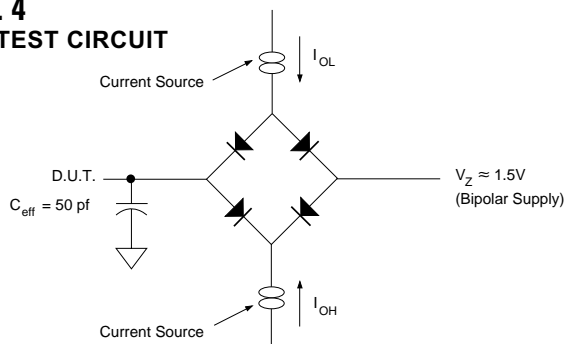

AC TEST CONDITIONS

Parameter	Typ	Unit
Input Pulse Levels	V _{IL} = 0, V _{IH} = 3.0	V
Input Rise and Fall	5	ns
Input and Output Reference Level	1.5	V
Output Timing Reference Level	1.5	V

NOTES:

V_Z is programmable from -2V to +7V.
 I_{OL} & I_{OH} programmable from 0 to 16mA.
 Tester Impedance Z₀ = 75 Ω.
 V_Z is typically the midpoint of V_{OH} and V_{OL}.
 I_{OL} & I_{OH} are adjusted to simulate a typical resistive load circuit.
 ATE tester includes jig capacitance.



FIG. 5
TIMING WAVEFORM - READ CYCLE

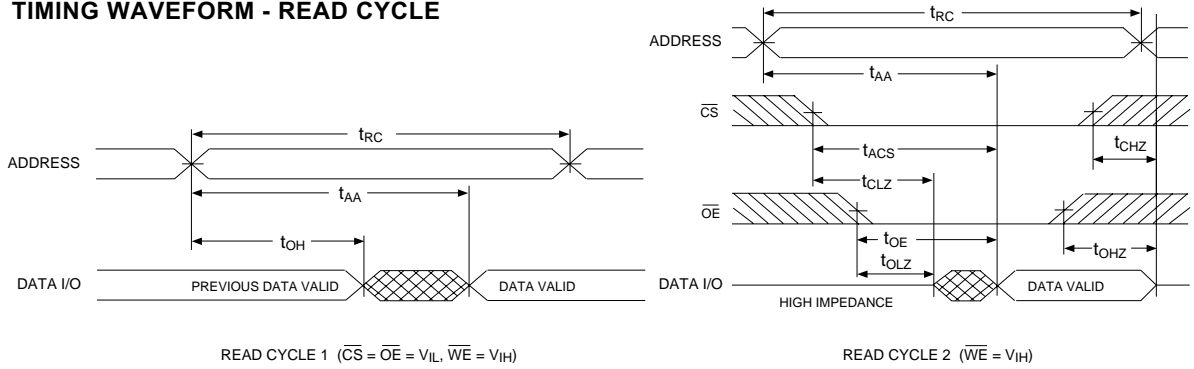

FIG. 6
WRITE CYCLE - \overline{WE} CONTROLLED

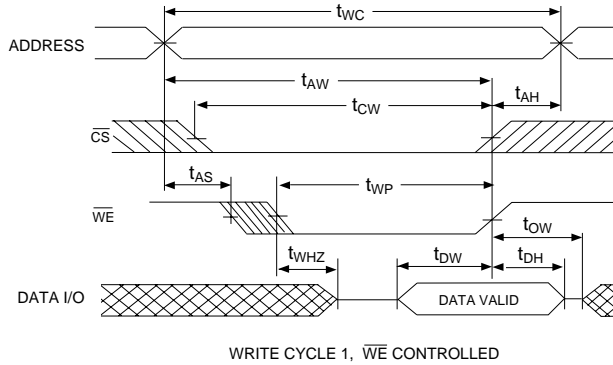
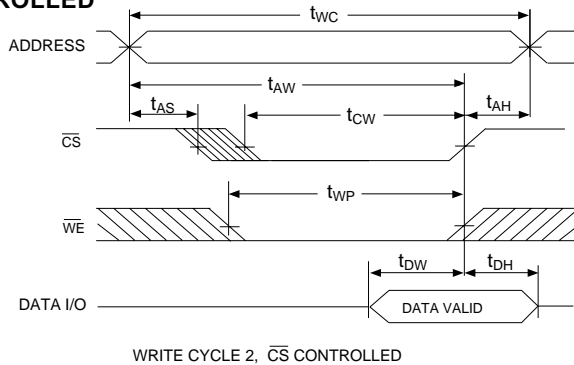
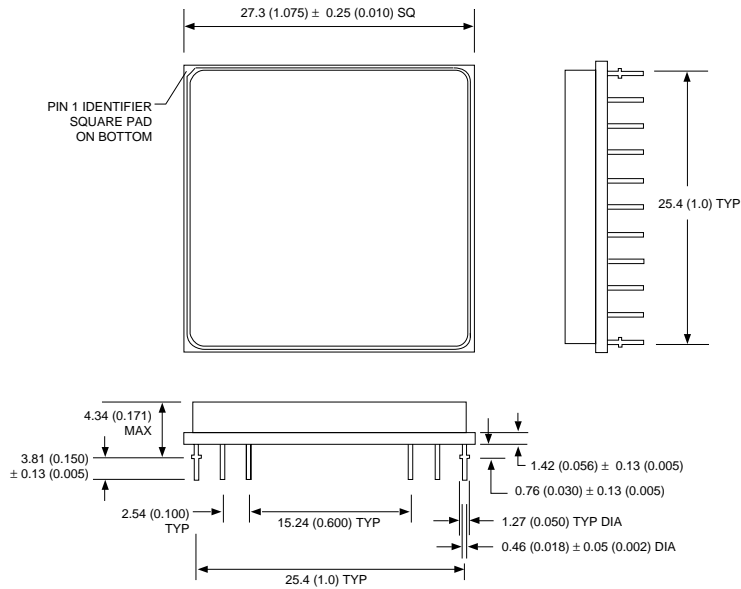

FIG. 7
WRITE CYCLE - \overline{CS} CONTROLLED





PACKAGE 400: 66 PIN, PGA TYPE, CERAMIC HEX-IN-LINE PACKAGE, HIP (H1)



ALL LINEAR DIMENSIONS ARE MILLIMETERS AND PARENTHETICALLY IN INCHES

PACKAGE 502: 68 LEAD, CERAMIC QUAD FLAT PACK, LOW PROFILE CQFP (G4T)

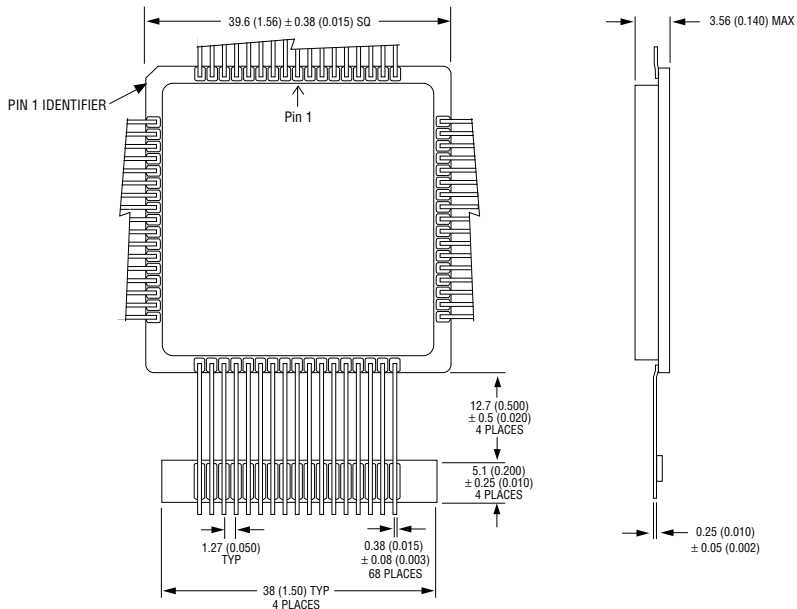

ALL LINEAR DIMENSIONS ARE MILLIMETERS AND PARENTHETICALLY IN INCHES



PACKAGE 509: 68 LEAD, LOW PROFILE CERAMIC QUAD FLAT PACK, CQFP (G2T)

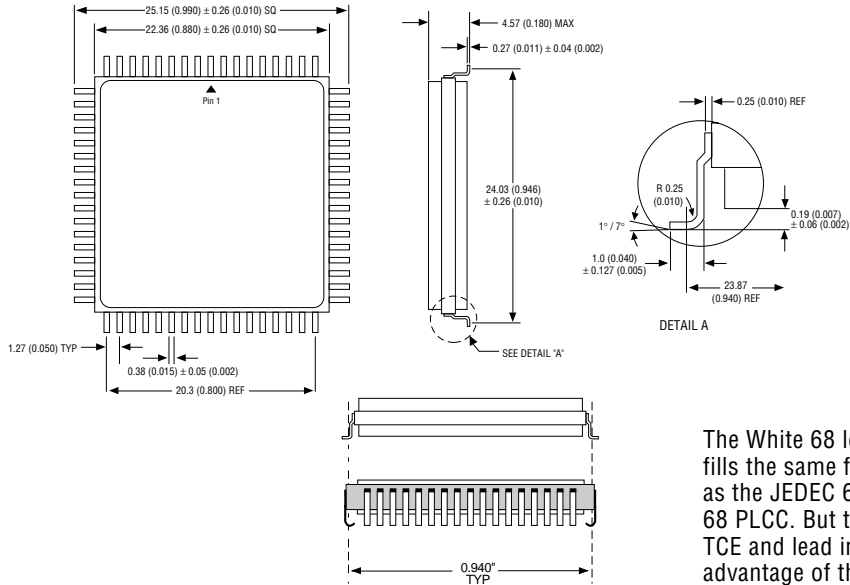

The White 68 lead G2T CQFP fills the same fit and function as the JEDEC 68 lead CQFJ or 68 PLCC. But the G2T has the TCE and lead inspection advantage of the CQFP form.

ALL LINEAR DIMENSIONS ARE MILLIMETERS AND PARENTHETICALLY IN INCHES

PACKAGE 519: 68 LEAD, CERAMIC QUAD FLAT PACK, LOW PROFILE CQFP (G1U)

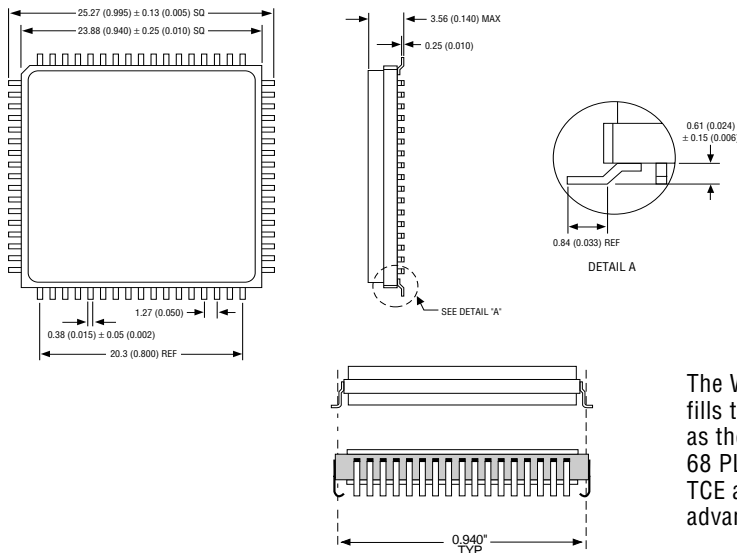

The White 68 lead G1U CQFP fills the same fit and function as the JEDEC 68 lead CQFJ or 68 PLCC. But the G1U has the TCE and lead inspection advantage of the CQFP form.

ALL LINEAR DIMENSIONS ARE MILLIMETERS AND PARENTHETICALLY IN INCHES



ORDERING INFORMATION

W S 128K 32 X - XXX X X X

LEAD FINISH:

- Blank = Gold plated leads
- A = Solder dip leads

DEVICE GRADE:

- Q = MIL-STD-883 Compliant
- M = Military Screened -55°C to +125°C
- I = Industrial -40°C to +85°C
- C = Commercial 0°C to +70°C

PACKAGE TYPE:

- H1 = 1.075" sq. Ceramic Hex-In-line Package, HIP (Package 400)
- G2T = 22.4mm Ceramic Quad Flat Pack, CQFP (Package 509)
- G1U = 22.4mm Ceramic Quad Flat Pack, Low Profile CQFP (Package 519)
- G4T = 40 mm Low Profile CQFP (Package 502)

ACCESS TIME (ns)

IMPROVEMENT MARK:

- N = No Connect at pin 8, 21, 28 and 39 in HIP for Upgrades
- L = Low Power

ORGANIZATION, 128Kx32

User configurable as 256Kx16 or 512Kx8

SRAM

WHITE ELECTRONIC DESIGNS CORPORATION



DEVICE TYPE	SPEED	PACKAGE	SMD NO.
128K x 32 SRAM Module	55ns	66 pin HIP (H1)	5962-93187 05H4X
128K x 32 SRAM Module	45ns	66 pin HIP (H1)	5962-93187 06H4X
128K x 32 SRAM Module	35ns	66 pin HIP (H1)	5962-93187 07H4X
128K x 32 SRAM Module	25ns	66 pin HIP (H1)	5962-93187 08H4X
128K x 32 SRAM Module	20ns	66 pin HIP (H1)	5962-93187 09H4X
128K x 32 SRAM Module	17ns	66 pin HIP (H1)	5962-93187 10H4X
128K x 32 SRAM Module	15ns	66 pin HIP (H1)	5962-93187 11H4X
128K x 32 SRAM Module	55ns	68 lead CQFP Low Profile (G4T)	5962-95595 05HYX
128K x 32 SRAM Module	45ns	68 lead CQFP Low Profile (G4T)	5962-95595 06HYX
128K x 32 SRAM Module	35ns	68 lead CQFP Low Profile (G4T)	5962-95595 07HYX
128K x 32 SRAM Module	25ns	68 lead CQFP Low Profile (G4T)	5962-95595 08HYX
128K x 32 SRAM Module	20ns	68 lead CQFP Low Profile (G4T)	5962-95595 09HYX
128K x 32 SRAM Module	17ns	68 lead CQFP Low Profile (G4T)	5962-95595 10HYX
128K x 32 SRAM Module	15ns	68 lead CQFP Low Profile (G4T)	5962-95595 11HYX
128K x 32 SRAM Module	55ns	68 lead CQFP/J (G2T)	5962-95595 05HMX
128K x 32 SRAM Module	45ns	68 lead CQFP/J (G2T)	5962-95595 06HMX
128K x 32 SRAM Module	35ns	68 lead CQFP/J (G2T)	5962-95595 07HMX
128K x 32 SRAM Module	25ns	68 lead CQFP/J (G2T)	5962-95595 08HMX
128K x 32 SRAM Module	20ns	68 lead CQFP/J (G2T)	5962-95595 09HMX
128K x 32 SRAM Module	17ns	68 lead CQFP/J (G2T)	5962-95595 10HMX
128K x 32 SRAM Module	15ns	68 lead CQFP/J (G2T)	5962-95595 11HMX
128K x 32 SRAM Module	55ns	68 lead CQFP/J(G1U)	5962-95595 05H9X
128K x 32 SRAM Module	45ns	68 lead CQFP/J (G1U)	5962-95595 06H9X
128K x 32 SRAM Module	35ns	68 lead CQFP/J (G1U)	5962-95595 07H9X
128K x 32 SRAM Module	25ns	68 lead CQFP/J (G1U)	5962-95595 08H9X
128K x 32 SRAM Module	20ns	68 lead CQFP/J (G1U)	5962-95595 09H9X
128K x 32 SRAM Module	17ns	68 lead CQFP/J (G1U)	5962-95595 10H9X
128K x 32 SRAM Module	15ns	68 lead CQFP/J (G1U)	5962-95595 11H9X