

# 260MHZ, CRYSTAL-TO-LVCMOS LVTTTL FREQUENCY SYNTHESIZER

**ICS84021**

## GENERAL DESCRIPTION



The ICS84021 is a general purpose, Crystal-to-LVCMOS/LVTTTL High Frequency Synthesizer and a member of the HiPerClockS™ family of High Performance Clock Solutions from ICS. The ICS84021 has a selectable TEST\_CLK or crystal input. The VCO operates at a frequency range of 620MHz to 780MHz. The VCO frequency is programmed in steps equal to the value of the input reference or crystal frequency. The VCO and output frequency can be programmed using the serial or parallel interface to the configuration logic.

## FEATURES

- 2 LVCMOS/LVTTTL outputs
  - Selectable crystal oscillator interface or LVCMOS/LVTTTL TEST\_CLK
  - Output frequency range: 103.3MHz to 260MHz
  - Crystal input frequency range: 14MHz to 40MHz
  - VCO range: 620MHz to 780MHz
  - Parallel or serial interface for programming counter and output dividers
  - RMS period jitter: 4.3ps (typical) ( $N \div 4$ ,  $V_{DD0} = 3.3V \pm 5\%$ )
  - RMS phase jitter at 155.52MHz, using a 38.88MHz crystal (12kHz to 20MHz): 2.88ps (typical)
- Phase noise: 155.52MHz
- | Offset | Noise Power   |
|--------|---------------|
| 100Hz  | -93.7 dBc/Hz  |
| 1KHz   | -111.3 dBc/Hz |
| 10KHz  | -120.4 dBc/Hz |
| 100KHz | -125.1 dBc/Hz |
- Full 3.3V or mixed 3.3V core/2.5V or 1.8V supply voltage
  - 0°C to 70°C ambient operating temperature
  - Industrial temperature information available upon request
  - Lead-Free package fully RoHS compliant

## BLOCK DIAGRAM

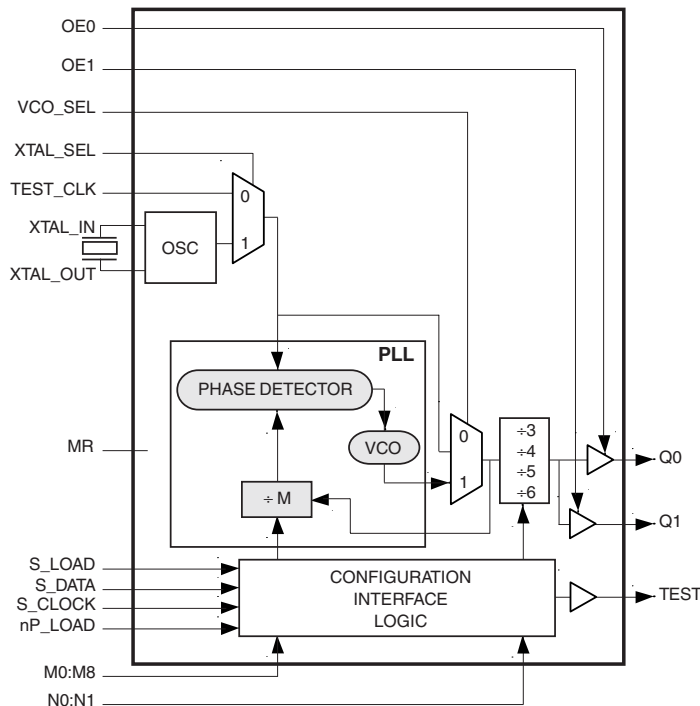

## PIN ASSIGNMENT

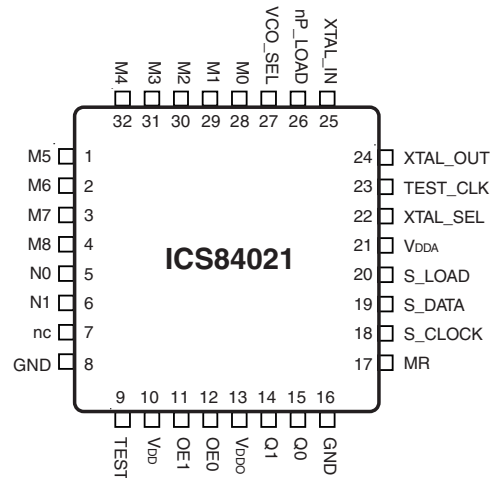

**32-Lead LQFP**  
7mm x 7mm x 1.4mm package body  
**Y Package**  
Top View

## FUNCTIONAL DESCRIPTION

**NOTE:** The functional description that follows describes operation using a 25MHz crystal. Valid PLL loop divider values for different crystal or input frequencies are defined in the Input Frequency Characteristics, Table 5, NOTE 1.

The ICS84021 features a fully integrated PLL and therefore requires no external components for setting the loop bandwidth. A fundamental crystal is used as the input to the on-chip oscillator. The output of the oscillator is fed into the phase detector. A 25MHz crystal provides a 25MHz phase detector reference frequency. The VCO of the PLL operates over a range of 620MHz to 780MHz. The output of the M divider is also applied to the phase detector.

The phase detector and the M divider force the VCO output frequency to be M times the reference frequency by adjusting the VCO control voltage. Note that for some values of M (either too high or too low), the PLL will not achieve lock. The output of the VCO is scaled by a divider prior to being sent to each of the LVCMOS output buffers. The divider provides a 50% output duty cycle.

The programmable features of the ICS84021 support two input modes to program the M divider and N output divider. The two input operational modes are parallel and serial. Figure 1 shows the timing diagram for each mode. In parallel mode, the nP\_LOAD input is initially LOW. The data on inputs M0 through M8 and N0 and N1 is passed directly to the M divider and N output divider. On the LOW-to-HIGH transition of the nP\_LOAD input, the data is latched and the M divider remains loaded until the next LOW transition on nP\_LOAD or until a serial event occurs. As a result, the M and N bits can be hardwired to set the

M divider and N output divider to a specific default state that will automatically occur during power-up. The TEST output is LOW when operating in the parallel input mode. The relationship between the VCO frequency, the crystal frequency and the M divider is defined as follows:  $f_{VCO} = f_{xtal} \times M$

The M value and the required values of M0 through M8 are shown in Table 3B, Programmable VCO Frequency Function Table. Valid M values for which the PLL will achieve lock for a 25MHz reference are defined as  $25 \leq M \leq 31$ . The frequency out is defined as follows:  $F_{OUT} = \frac{f_{VCO}}{N} = f_{xtal} \times \frac{M}{N}$

Serial operation occurs when nP\_LOAD is HIGH and S\_LOAD is LOW. The shift register is loaded by sampling the S\_DATA bits with the rising edge of S\_CLOCK. The contents of the shift register are loaded into the M divider and N output divider when S\_LOAD transitions from LOW-to-HIGH. The M divide and N output divide values are latched on the HIGH-to-LOW transition of S\_LOAD. If S\_LOAD is held HIGH, data at the S\_DATA input is passed directly to the M divider and N output divider on each rising edge of S\_CLOCK. The serial mode can be used to program the M and N bits and test bits T1 and T0. The internal registers T0 and T1 determine the state of the TEST output as follows:

T1	T0	TEST Output
0	0	LOW
0	1	S_DATA, Shift Register Input
1	0	Output of M divider
1	1	CMOS Fout

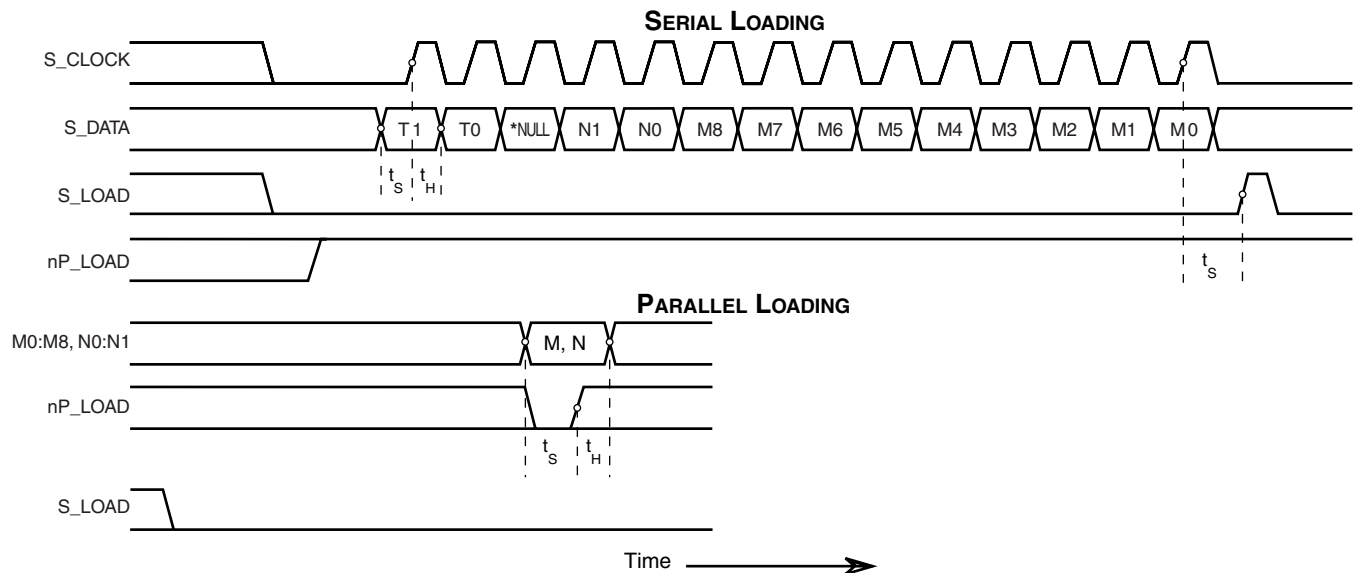

FIGURE 1. PARALLEL & SERIAL LOAD OPERATIONS

\*NOTE: The NULL timing slot must be observed.

TABLE 1. PIN DESCRIPTIONS

Number	Name	Type		Description
1	M5	Input	Pullup	M divider inputs. Data latched on LOW-to-HIGH transition of nP_LOAD input. LVCMOS / LVTTTL interface levels.
2, 3, 4, 28, 29, 30, 31, 32	M6, M7, M8, M0, M1, M2, M3, M4	Input	Pulldown	
5, 6	N0, N1	Input	Pulldown	Determines output divider value as defined in Table 3C, Function Table. LVCMOS / LVTTTL interface levels.
7	nc	Unused		No connect.
8, 16	GND	Power		Power supply ground.
9	TEST	Output		Test output which is ACTIVE in the serial mode of operation. Output driven LOW in parallel mode. LVCMOS / LVTTTL interface levels.
10	V <sub>DD</sub>	Power		Core supply pin.
11, 12	OE1, OE0	Input	Pullup	Output enable. When logic HIGH, the outputs are enabled (default). When logic LOW, the outputs are in Tri-State. See Table 3E, OE Function Table. LVCMOS / LVTTTL interface levels.
13	V <sub>DDO</sub>	Power		Output supply pin.
14, 15	Q0, Q1	Output		Clock outputs. LVCMOS / LVTTTL interface levels.
17	MR	Input	Pulldown	Active High Master Reset. When logic HIGH, the internal dividers are reset causing the outputs to go low. When logic LOW, the internal dividers and the outputs are enabled. Assertion of MR does not effect loaded M, N, and T values. LVCMOS / LVTTTL interface levels.
18	S_CLOCK	Input	Pulldown	Clocks in serial data present at S_DATA input into the shift register on the rising edge of S_CLOCK. LVCMOS / LVTTTL interface levels.
19	S_DATA	Input	Pulldown	Shift register serial input. Data sampled on the rising edge of S_CLOCK. LVCMOS / LVTTTL interface levels.
20	S_LOAD	Input	Pulldown	Controls transition of data from shift register into the dividers. LVCMOS / LVTTTL interface levels.
21	V <sub>DDA</sub>	Power		Analog supply pin.
22	XTAL_SEL	Input	Pullup	Selects between crystal or test inputs as the PLL reference source. Selects XTAL inputs when HIGH. Selects TEST_CLK when LOW. LVCMOS / LVTTTL interface levels
23	TEST_CLK	Input	Pulldown	Test clock input. LVCMOS / LVTTTL interface levels.
24, 25	XTAL_OUT, XTAL_IN	Input		Crystal oscillator interface. XTAL_IN is the input. XTAL_OUT is the output.
26	nP_LOAD	Input	Pulldown	Parallel load input. Determines when data present at M8:M0 is loaded into M divider, and when data present at N1:N0 sets the N output divider value. LVCMOS / LVTTTL interface levels.
27	VCO_SEL	Input	Pullup	Determines whether synthesizer is in PLL or bypass mode. LVCMOS / LVTTTL interface levels.

NOTE: *Pullup* and *Pulldown* refer to internal input resistors. See Table 2, Pin Characteristics, for typical values.

TABLE 2. PIN CHARACTERISTICS

Symbol	Parameter	Test Conditions	Minimum	Typical	Maximum	Units
$C_{IN}$	Input Capacitance			4		pF
$C_{PD}$	Power Dissipation Capacitance (per output)	$V_{DD}, V_{DDA}, V_{DDO} = 3.465V$		15		pF
		$V_{DD}, V_{DDA} = 3.465V, V_{DDO} = 2.625V$		15		pF
		$V_{DD}, V_{DDA} = 3.465V, V_{DDO} = 1.89V$		20		pF
$R_{PULLUP}$	Input Pullup Resistor			51		k $\Omega$
$R_{PULLDOWN}$	Input Pulldown Resistor			51		k $\Omega$
$R_{OUT}$	Output Impedance	$V_{DDO} = 3.465V$		7		$\Omega$
		$V_{DDO} = 2.625V$		7		$\Omega$
		$V_{DDO} = 1.89V$		10		$\Omega$

TABLE 3A. PARALLEL AND SERIAL MODE FUNCTION TABLE

Inputs							Conditions
MR	nP_LOAD	M	N	S_LOAD	S_CLOCK	S_DATA	
H	X	X	X	X	X	X	Reset. Forces outputs LOW.
L	L	Data	Data	X	X	X	Data on M and N inputs passed directly to the M divider and N output divider. TEST output forced LOW.
L	↑	Data	Data	L	X	X	Data is latched into input registers and remains loaded until next LOW transition or until a serial event occurs.
L	H	X	X	L	↑	Data	Serial input mode. Shift register is loaded with data on S_DATA on each rising edge of S_CLOCK.
L	H	X	X	↑	L	Data	Contents of the shift register are passed to the M divider and N output divider.
L	H	X	X	↓	L	Data	M divider and N output divider values are latched.
L	H	X	X	L	X	X	Parallel or serial input do not affect shift registers.
L	H	X	X	H	↑	Data	S_DATA passed directly to M divider as it is clocked.

NOTE: L = LOW

H = HIGH

X = Don't care

↑ = Rising edge transition

↓ = Falling edge transition

TABLE 3B. PROGRAMMABLE VCO FREQUENCY FUNCTION TABLE (NOTE 1)

VCO Frequency (MHz)	M Divide	256	128	64	32	16	8	4	2	1
		M8	M7	M6	M5	M4	M3	M2	M1	M0
625	25	0	0	0	0	1	1	0	0	1
•	•	•	•	•	•	•	•	•	•	•
700	28	0	0	0	0	1	1	1	0	0
•	•	•	•	•	•	•	•	•	•	•
775	31	0	0	0	0	1	1	1	1	1

NOTE 1: These M divide values and the resulting frequencies correspond to crystal or TEST\_CLK input frequency of 25MHz.

TABLE 3C. PROGRAMMABLE OUTPUT DIVIDER FUNCTION TABLE (PLL ENABLED)

Inputs		N Divider Value	Output Frequency (MHz)	
N1	N0		Minimum	Maximum
0	0	3	206.7	260
0	1	4	155	195
1	0	5	124	156
1	1	6	103.3	130

TABLE 3D. COMMONLY USED CONFIGURATION FUNCTION TABLE

Input			Output Frequency (MHz)
Crystal (MHz)	M Divider Value	N Divider Value	
19.44	32	4	155.52
19.53125	32	4	156.25
25	25	4	156.25
25	25	5	125
25.50	25	3	212.50
25.50	25	4	159.375
25.50	25	6	106.25
38.88	16	4	155.52

TABLE 3E. OUTPUT ENABLE &amp; CLOCK ENABLE FUNCTION TABLE

Control Inputs		Output	
OE0	OE1	Q0	Q1
0	0	Hi-Z	Hi-Z
0	1	Hi-Z	Enabled
1	0	Enabled	Hi-Z
1	1	Enabled	Enabled

**ABSOLUTE MAXIMUM RATINGS**

Supply Voltage, $V_{DD}$	4.6V
Inputs, $V_I$	-0.5V to $V_{DD} + 0.5V$
Outputs, $V_O$	-0.5V to $V_{DDO} + 0.5V$
Package Thermal Impedance, $\theta_{JA}$	47.9°C/W (0 lfpm)
Storage Temperature, $T_{STG}$	-65°C to 150°C

NOTE: Stresses beyond those listed under Absolute Maximum Ratings may cause permanent damage to the device. These ratings are stress specifications only. Functional operation of product at these conditions or any conditions beyond those listed in the *DC Characteristics* or *AC Characteristics* is not implied. Exposure to absolute maximum rating conditions for extended periods may affect product reliability.

**TABLE 4A. POWER SUPPLY DC CHARACTERISTICS,  $V_{DD}=V_{DDA}=3.3V\pm5\%$ ,  $V_{DDO}=3.3V\pm5\%$ ,  $2.5V\pm5\%$  OR  $1.8V\pm5\%$ ,  $T_A=0^\circ\text{C}$  TO  $70^\circ\text{C}$**

Symbol	Parameter	Test Conditions	Minimum	Typical	Maximum	Units
$V_{DD}$	Core Supply Voltage		3.135	3.3	3.465	V
$V_{DDA}$	Analog Supply Voltage		3.135	3.3	3.465	V
$V_{DDO}$	Output Supply Voltage		3.135	3.3	3.465	V
			2.375	2.5	2.625	V
			1.71	1.8	1.89	V
$I_{DD}$	Power Supply Current			140	mA	
$I_{DDA}$	Analog Supply Current			25	mA	
$I_{DDO}$	Output Supply Current			5	mA	

TABLE 4B. LVCMOS / LVTTTL DC CHARACTERISTICS,  $V_{DD}=V_{DDA}=3.3V\pm5\%$ , $V_{DDO}=3.3V\pm5\%$ ,  $2.5V\pm5\%$  OR  $1.8V\pm5\%$ ,  $T_A=0^{\circ}C$  TO  $70^{\circ}C$ 

Symbol	Parameter	Test Conditions	Minimum	Typical	Maximum	Units
$V_{IH}$	Input High Voltage	VCO_SEL, XTAL_SEL, MR, S_LOAD, nP_LOAD, S_DATA, S_CLOCK, OE0, OE1, N0:N1, M0:M8	2		$V_{DD} + 0.3$	V
		TEST_CLK	2		$V_{DD} + 0.3$	V
$V_{IL}$	Input Low Voltage	VCO_SEL, XTAL_SEL, MR, S_LOAD, nP_LOAD, S_DATA, S_CLOCK, OE0, OE1, N0:N1, M0:M8	-0.3		0.8	V
		TEST_CLK	-0.3		1.3	V
$I_{IH}$	Input High Current	M0-M4, M6-M8, N0, N1, MR, S_CLOCK, TEST_CLK, S_DATA, S_LOAD, nP_LOAD	$V_{DD} = V_{IN} = 3.465V$		150	$\mu A$
		M5, OE0, OE1, XTAL_SEL, VCO_SEL	$V_{DD} = V_{IN} = 3.465V$		5	$\mu A$
$I_{IL}$	Input Low Current	M0-M4, M6-M8, N0, N1, MR, S_CLOCK, TEST_CLK, S_DATA, S_LOAD, nP_LOAD	$V_{DD} = 3.465V$ , $V_{IN} = 0V$	-5		$\mu A$
		M5, OE0, OE1, XTAL_SEL, VCO_SEL	$V_{DD} = 3.465V$ , $V_{IN} = 0V$	-150		$\mu A$
$V_{OH}$	Output High Voltage; NOTE 1	$V_{DDO} = 3.3V \pm 5\%$	2.6			V
		$V_{DDO} = 2.5V \pm 5\%$	1.8			V
		$V_{DDO} = 1.8V \pm 5\%$	$V_{DDO} - 0.3$			V
$V_{OL}$	Output Low Voltage; NOTE 1	$V_{DDO} = 3.3V \pm 5\%$			0.5	V
		$V_{DDO} = 2.5V \pm 5\%$			0.5	V
		$V_{DDO} = 1.8V \pm 5\%$			0.4	V

NOTE 1: Outputs terminated with  $50\Omega$  to  $V_{DDO}/2$ . See *Parameter Measurement Section*, "Load Test Circuit Diagrams".TABLE 5. INPUT FREQUENCY CHARACTERISTICS,  $V_{DD}=V_{DDA}=V_{DDO}=3.3V\pm5\%$ ,  $T_A=0^{\circ}C$  TO  $70^{\circ}C$ 

Symbol	Parameter	Test Conditions	Minimum	Typical	Maximum	Units
$f_{IN}$	Input Frequency	TEST_CLK; NOTE 1	14		40	MHz
		XTAL_IN, XTAL_OUT; NOTE 1	14		40	MHz
		S_CLOCK			50	MHz

NOTE 1: For the input crystal and TEST\_CLK frequency range, the M value must be set for the VCO to operate within the 620MHz to 780MHz range. Using the minimum input frequency of 14MHz, valid values of M are  $45 \leq M \leq 55$ . Using the maximum frequency of 40MHz, valid values of M are  $16 \leq M \leq 19$ .

TABLE 6. CRYSTAL CHARACTERISTICS

Parameter	Test Conditions	Minimum	Typical	Maximum	Units
Mode of Oscillation		Fundamental			
Frequency		14		40	MHz
Equivalent Series Resistance (ESR)				50	$\Omega$
Shunt Capacitance ( $C_o$ )				7	pF
Drive Level				1	mW

**TABLE 7A. AC CHARACTERISTICS,  $V_{DD} = V_{DDA} = V_{DDO} = 3.3V \pm 5\%$ ,  $T_A = 0^\circ\text{C}$  TO  $70^\circ\text{C}$** 

Symbol	Parameter	Test Conditions	Minimum	Typical	Maximum	Units
$F_{OUT}$	Output Frequency		103.3		260	MHz
$f_{jit(per)}$	Period Jitter, RMS; NOTE 1	$N \div 3$		7.5	10	ps
		$N \div 4$		4.3	7	ps
		$N \div 5$		4.1	6	ps
		$N \div 6$		12.9	16	ps
$t_{sk(o)}$	Output Skew; NOTE 2, 3				100	ps
$t_R / t_F$	Output Rise/Fall Time	20% to 80%	300		800	ps
$t_S$	Setup Time	M, N to nP_LOAD	5			ns
		S_DATA to S_CLOCK	5			ns
		S_CLOCK to S_LOAD	5			ns
$t_H$	Hold Time	M, N to nP_LOAD	5			ns
		S_DATA to S_CLOCK	5			ns
		S_CLOCK to S_LOAD	5			ns
odc	Output Duty Cycle		45		55	%
$t_{LOCK}$	PLL Lock Time				1	ms

See Parameter Measurement Information section.

NOTE 1: Jitter performance using XTAL inputs.

NOTE 2: Defined as skew between outputs at the same supply voltage and with equal load conditions. Measured at  $V_{DDO}/2$ .

NOTE 3: This parameter is defined in accordance with JEDEC Standard 65.

**TABLE 7B. AC CHARACTERISTICS,  $V_{DD} = V_{DDA} = 3.3V \pm 5\%$ ,  $V_{DDO} = 2.5V \pm 5\%$ ,  $T_A = 0^\circ\text{C}$  TO  $70^\circ\text{C}$** 

Symbol	Parameter	Test Conditions	Minimum	Typical	Maximum	Units
$F_{OUT}$	Output Frequency		103.3		260	MHz
$f_{jit(per)}$	Period Jitter, RMS; NOTE 1	$N \div 3$		6.4	8	ps
		$N \div 4$		4.3	8	ps
		$N \div 5$		4.2	7	ps
		$N \div 6$		9	12	ps
$t_{sk(o)}$	Output Skew; NOTE 2, 3				90	ps
$t_R / t_F$	Output Rise/Fall Time	20% to 80%	300		800	ps
$t_S$	Setup Time	M, N to nP_LOAD	5			ns
		S_DATA to S_CLOCK	5			ns
		S_CLOCK to S_LOAD	5			ns
$t_H$	Hold Time	M, N to nP_LOAD	5			ns
		S_DATA to S_CLOCK	5			ns
		S_CLOCK to S_LOAD	5			ns
odc	Output Duty Cycle		45		55	%
$t_{LOCK}$	PLL Lock Time				1	ms

See Parameter Measurement Information section.

NOTE 1: Jitter performance using XTAL inputs.

NOTE 2: Defined as skew between outputs at the same supply voltage and with equal load conditions. Measured at  $V_{DDO}/2$ .

NOTE 3: This parameter is defined in accordance with JEDEC Standard 65.



**TABLE 7C. AC CHARACTERISTICS,  $V_{DD} = V_{DDA} = 3.3V \pm 5\%$ ,  $V_{DDO} = 1.8V \pm 5\%$ ,  $T_A = 0^\circ C$  TO  $70^\circ C$** 

Symbol	Parameter	Test Conditions	Minimum	Typical	Maximum	Units
$F_{OUT}$	Output Frequency		103.3		260	MHz
$f_{jit(per)}$	Period Jitter, RMS; NOTE 1	$N \div 3$		6.8	8	ps
		$N \div 4$		4.5	8	ps
		$N \div 5$		4.2	6	ps
		$N \div 6$		8.5	10	ps
$t_{sk(o)}$	Output Skew; NOTE 2, 3				120	ps
$t_R / t_F$	Output Rise/Fall Time	20% to 80%	300		800	ps
$t_S$	Setup Time	M, N to nP_LOAD	5			ns
		S_DATA to S_CLOCK	5			ns
		S_CLOCK to S_LOAD	5			ns
$t_H$	Hold Time	M, N to nP_LOAD	5			ns
		S_DATA to S_CLOCK	5			ns
		S_CLOCK to S_LOAD	5			ns
odc	Output Duty Cycle		42		58	%
$t_{LOCK}$	PLL Lock Time				1	ms

See Parameter Measurement Information section.

NOTE 1: Jitter performance using XTAL inputs.

NOTE 2: Defined as skew between outputs at the same supply voltage and with equal load conditions. Measured at  $V_{DDO}/2$ .

NOTE 3: This parameter is defined in accordance with JEDEC Standard 65.

## PARAMETER MEASUREMENT INFORMATION

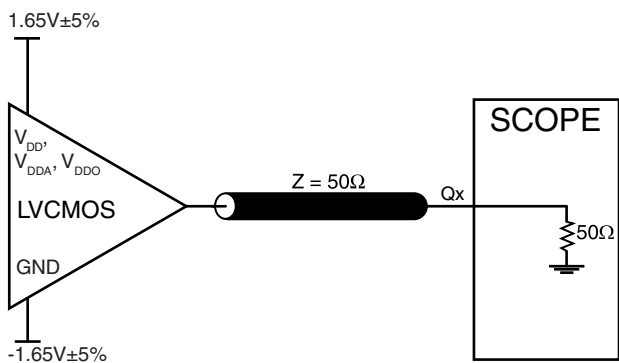

**3.3V OUTPUT LOAD AC TEST CIRCUIT**

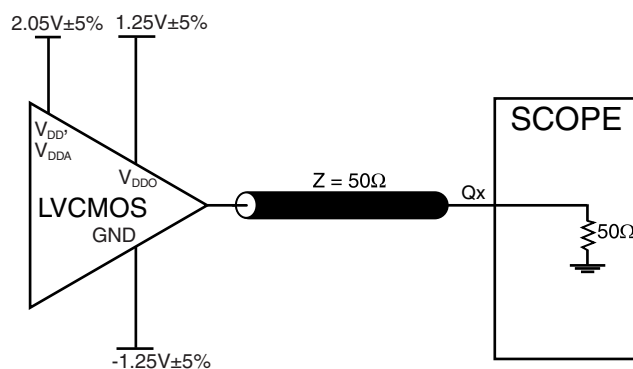

**3.3V/2.5V OUTPUT LOAD AC TEST CIRCUIT**

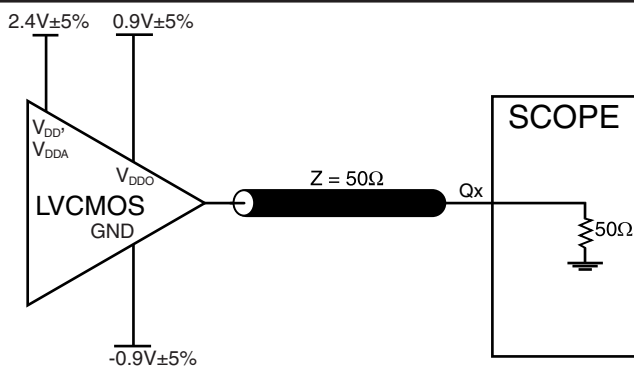

**3.3V/1.8V OUTPUT LOAD AC TEST CIRCUIT**

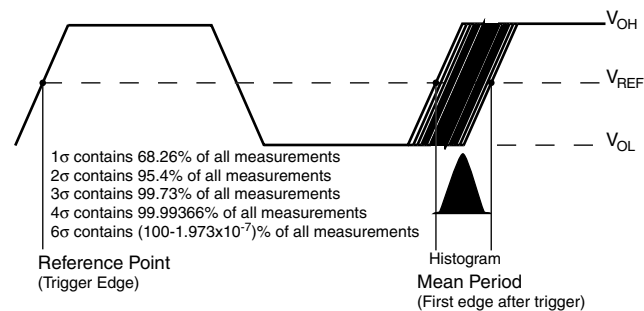

**PERIOD JITTER**

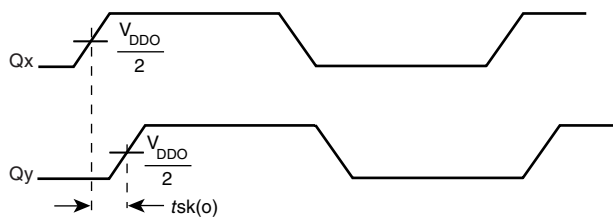

**OUTPUT SKEW**

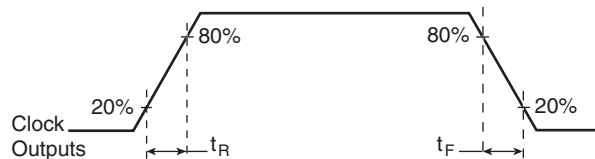

**OUTPUT RISE/FALL TIME**

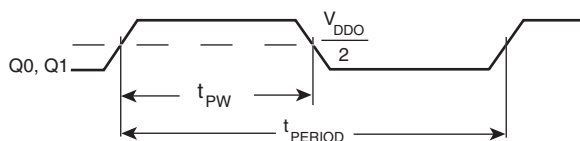

$$odc = \frac{t_{PW}}{t_{PERIOD}} \times 100\%$$

**OUTPUT DUTY CYCLE/PULSE WIDTH/PERIOD**

## APPLICATION INFORMATION

### POWER SUPPLY FILTERING TECHNIQUES

As in any high speed analog circuitry, the power supply pins are vulnerable to random noise. The ICS84021 provides separate power supplies to isolate any high switching noise from the outputs to the internal PLL.  $V_{DD}$ ,  $V_{DDA}$ , and  $V_{DDO}$  should be individually connected to the power supply plane through vias, and bypass capacitors should be used for each pin. To achieve optimum jitter performance, power supply isolation is required. *Figure 2* illustrates how a  $24\Omega$  resistor along with a  $10\mu\text{F}$  and a  $.01\mu\text{F}$  bypass capacitor should be connected to each  $V_{DDA}$  pin.

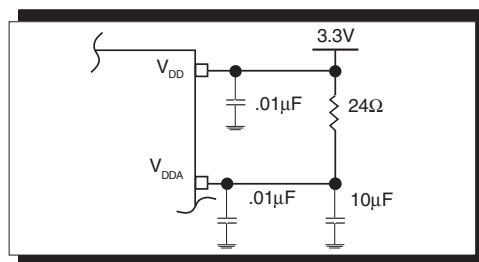

FIGURE 2. POWER SUPPLY FILTERING

### CRYSTAL INPUT INTERFACE

The ICS84021 has been characterized with 18pF parallel resonant crystals. The capacitor values, C1 and C2, shown in *Figure 3* below were determined using a 25MHz, 18pF

parallel resonant crystal and were chosen to minimize the ppm error. The optimum C1 and C2 values can be slightly adjusted for different board layouts.

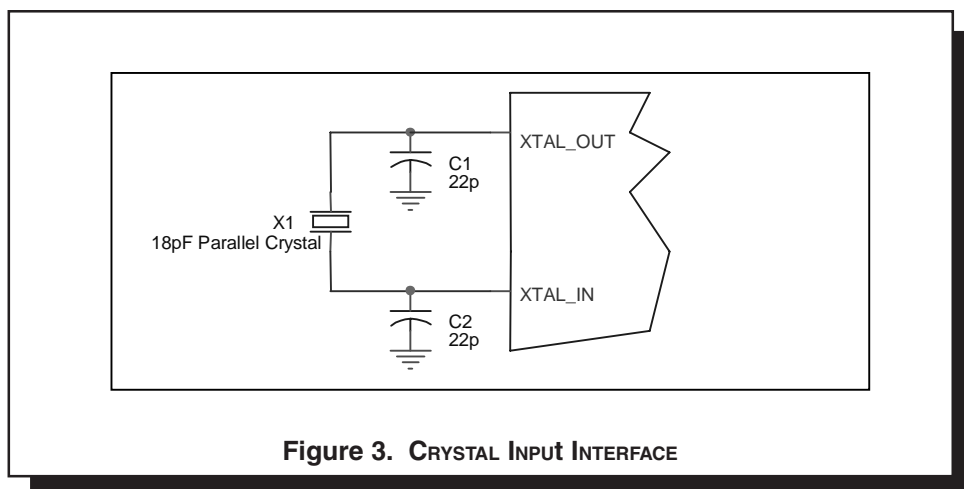
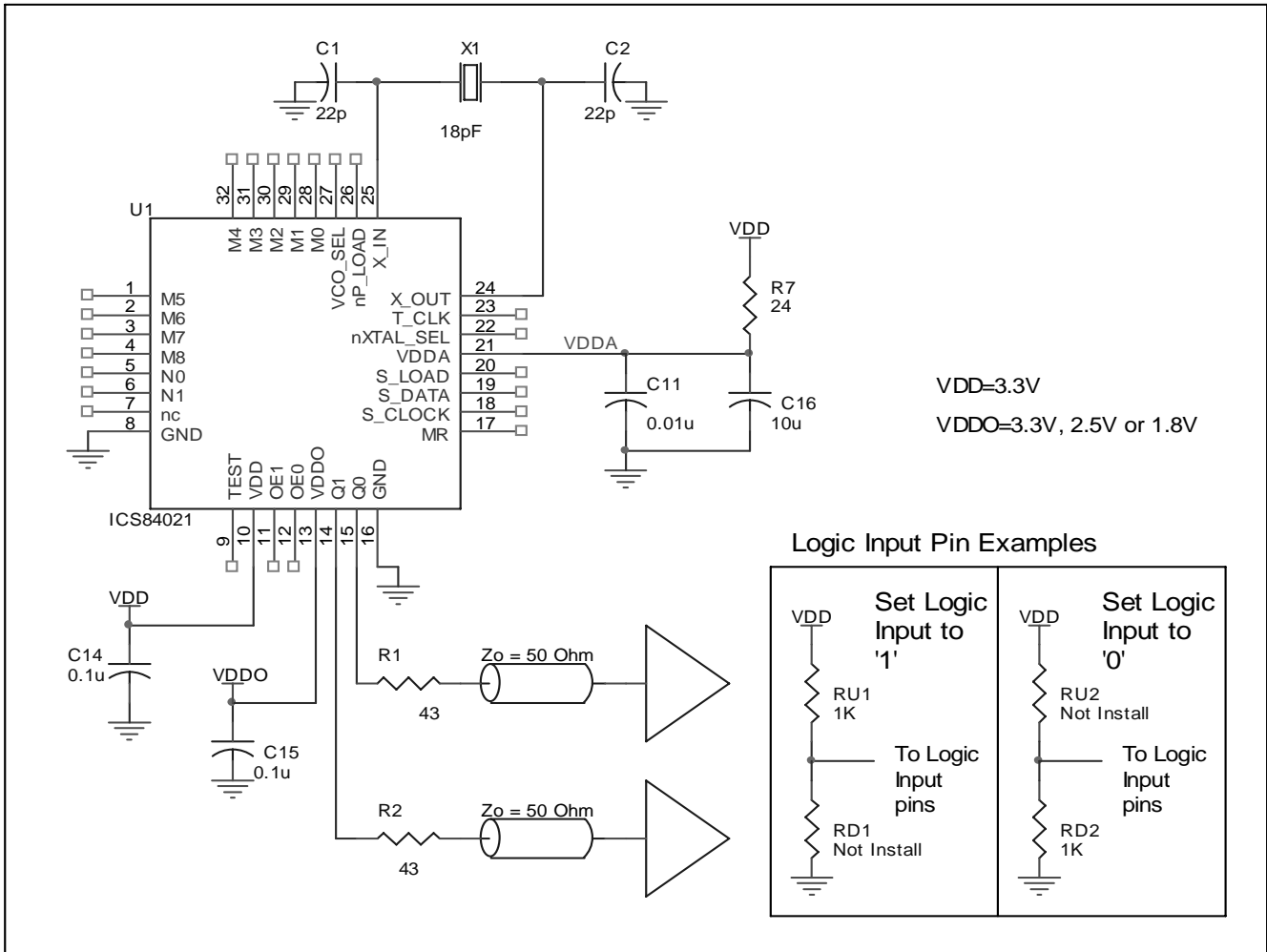

Figure 3. CRYSTAL INPUT INTERFACE

**APPLICATION SCHEMATIC EXAMPLE**

Figure 4 shows a schematic example of the ICS84021. In this example, a series termination is shown. Additional LVCMOS termination approaches are shown in the LVCMOS Termination Application Note. In this example, an

18pF parallel resonant crystal is used. The C1=22pF and C2=22pF are approximate values for frequency accuracy. The C1 and C2 may be slightly adjusted for optimizing frequency accuracy.



**FIGURE 4. ICS84021 APPLICATION SCHEMATIC EXAMPLE**

## RELIABILITY INFORMATION

TABLE 8.  $\theta_{JA}$  VS. AIR FLOW TABLE FOR 32 LEAD LQFP

$\theta_{JA}$ by Velocity (Linear Feet per Minute)			
	0	200	500
Single-Layer PCB, JEDEC Standard Test Boards	67.8°C/W	55.9°C/W	50.1°C/W
Multi-Layer PCB, JEDEC Standard Test Boards	47.9°C/W	42.1°C/W	39.4°C/W

**NOTE:** Most modern PCB designs use multi-layered boards. The data in the second row pertains to most designs.

### TRANSISTOR COUNT

The transistor count for ICS84021 is: 4325

## PACKAGE OUTLINE - Y SUFFIX FOR 32 LEAD LQFP

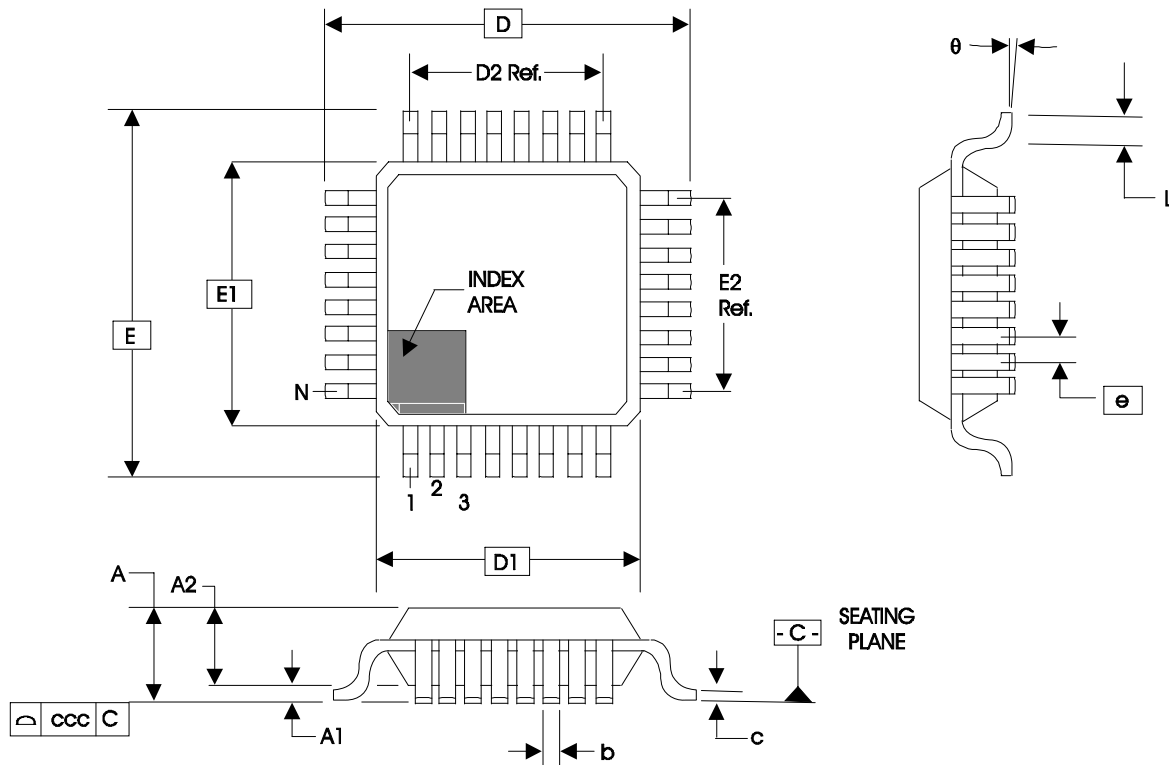

TABLE 9. PACKAGE DIMENSIONS

JEDEC VARIATION ALL DIMENSIONS IN MILLIMETERS			
SYMBOL	BBA		
	MINIMUM	NOMINAL	MAXIMUM
N	32		
A	--	--	1.60
A1	0.05	--	0.15
A2	1.35	1.40	1.45
b	0.30	0.37	0.45
c	0.09	--	0.20
D	9.00 BASIC		
D1	7.00 BASIC		
D2	5.60 Ref.		
E	9.00 BASIC		
E1	7.00 BASIC		
E2	5.60 Ref.		
e	0.80 BASIC		
L	0.45	0.60	0.75
$\theta$	0°	--	7°
ccc	--	--	0.10

Reference Document: JEDEC Publication 95, MS-026

TABLE 10. ORDERING INFORMATION

Part/Order Number	Marking	Package	Shipping Packaging	Temperature
84021AY	ICS84021AY	32 Lead LQFP	tray	0°C to 70°C
84021AYT	ICS84021AY	32 Lead LQFP	1000 tape & reel	0°C to 70°C
84021AYLF	ICS84021AYLF	32 Lead "Lead-Free" LQFP	tray	0°C to 70°C
84021AYLFT	ICS84021AYLF	32 Lead "Lead-Free" LQFP	1000 tape & reel	0°C to 70°C

NOTE: Parts that are ordered with an "LF" suffix to the part number are the Pb-Free configuration and are RoHS compliant.

The aforementioned trademark, HiPerClockS™ is a trademark of Integrated Circuit Systems, Inc. or its subsidiaries in the United States and/or other countries. While the information presented herein has been checked for both accuracy and reliability, Integrated Circuit Systems, Incorporated (ICS) assumes no responsibility for either its use or for infringement of any patents or other rights of third parties, which would result from its use. No other circuits, patents, or licenses are implied. This product is intended for use in normal commercial applications. Any other applications such as those requiring extended temperature range, high reliability, or other extraordinary environmental requirements are not recommended without additional processing by ICS. ICS reserves the right to change any circuitry or specifications without notice. ICS does not authorize or warrant any ICS product for use in life support devices or critical medical instruments.

REVISION HISTORY SHEET				
Rev	Table	Page	Description of Change	Date
B	T2	4 12	Pin Characteristics Table - added $R_{OUT}$ rows. Added Schematic Layout. Changed XTAL naming convention to XTAL_IN/XTAL_OUT throughout the data sheet.	1/5/04
C	T6 T10	1 2 7 15	Features Section - added Lead-Free bullet. Updated Parallel & Serial Load Operations Diagram. Crystal Characteristics Table - added Drive Level. Ordering Information Table - added Lead-Free package.	6/9/05



Innovate with IDT and accelerate your future networks. Contact:

**www.IDT.com**

**For Sales**

800-345-7015  
408-284-8200  
Fax: 408-284-2775

**For Tech Support**

clockhelp@idt.com  
408-284-8200

---

**Corporate Headquarters**

Integrated Device Technology, Inc.  
6024 Silver Creek Valley Road  
San Jose, CA 95138  
United States  
800 345 7015  
+408 284 8200 (outside U.S.)

**Asia Pacific and Japan**

Integrated Device Technology  
Singapore (1997) Pte. Ltd.  
Reg. No. 199707558G  
435 Orchard Road  
#20-03 Wisma Atria  
Singapore 238877  
+65 6 887 5505

**Europe**

IDT Europe, Limited  
Prime House  
Barnett Wood Lane  
Leatherhead, Surrey  
United Kingdom KT22 7DE  
+44 1372 363 339