

SIEMENS

TOPLED®

LS T670, LO T670, LY T670
LG T670, LP T670

Besondere Merkmale

- Gehäusebauform: P-LCC-2
- Gehäusefarbe: weiß
- als optischer Indikator einsetzbar
- zur Hinterleuchtung, Lichtleiter- und Linseneinkopplung
- für alle SMT-Bestück- und Löttechniken geeignet
- gegurtet (8-mm-Filmgurt)
- Störimpulsfest nach DIN 40839

Features

- P-LCC-2 package
- color of package: white
- for use as optical indicator
- for backlighting, optical coupling into light pipes and lenses
- suitable for all SMT assembly and soldering methods
- available taped on reel (8 mm tape)
- load dump resistant acc. to DIN 40839

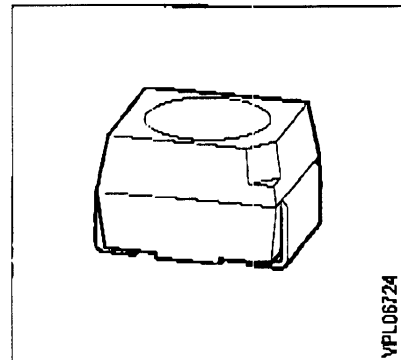

Typ	Emissions- farbe	Farbe der Lichtaustritts- fläche	Lichtstärke	Lichtstrom	Bestellnummer
Type	Color of Emission	Color of the Light Emitting Area	Luminous Intensity $I_F = 10 \text{ mA}$ $I_V \text{ (mcd)}$	Luminous Flux $I_F = 10 \text{ mA}$ $\Phi_V \text{ (mlm)}$	Ordering Code
LS T670-HK	super-red	colorless clear	2.5 ... 12.5	-	Q62703-Q2309
LS T670-J			4.0 ... 8.0	18 (typ.)	Q62703-Q2357
LS T670-K			6.3 ... 12.5	30 (typ.)	Q62703-Q2358
LS T670-L			10.0 ... 20.0	45 (typ.)	Q62703-Q3848
LS T670-JM			4.0 ... 32.0	-	Q62703-Q3849
LO T670-HK	orange	colorless clear	2.5 ... 12.5	-	Q62703-Q2310
LO T670-J			4.0 ... 8.0	18 (typ.)	Q62703-Q2475
LO T670-K			6.3 ... 12.5	30 (typ.)	Q62703-Q2476
LO T670-L			10.0 ... 20.0	45 (typ.)	Q62703-Q3850
LO T670-JM			4.0 ... 32.0	-	Q62703-Q3851
LY T670-HK	yellow	colorless clear	2.5 ... 12.5	-	Q62703-Q2311
LY T670-J			4.0 ... 8.0	18 (typ.)	Q62703-Q2376
LY T670-K			6.3 ... 12.5	30 (typ.)	Q62703-Q2375
LY T670-L			10.0 ... 20.0	45 (typ.)	Q62703-Q3098
LY T670-JM			4.0 ... 32.0	-	Q62703-Q3852
LG T670-HK	green	colorless clear	2.5 ... 12.5	-	Q62703-Q2312
LG T670-J			4.0 ... 8.0	18 (typ.)	Q62703-Q2377
LG T670-K			6.3 ... 12.5	30 (typ.)	Q62703-Q2378
LG T670-L			10.0 ... 20.0	45 (typ.)	Q62703-Q3146
LG T670-JM			4.0 ... 32.0	-	Q62703-Q3853
LP T670-FJ	pure green	colorless clear	1.0 ... 2.0	-	Q62703-Q2619
LP T670-G			1.6 ... 3.2	8 (typ.)	Q62703-Q3102
LP T670-H			2.5 ... 5.0	12 (typ.)	Q62703-Q2555
LP T670-J			4.0 ... 8.0	18 (typ.)	Q62703-Q2553
LP T670-GK			1.6 ... 12.5	-	Q62703-Q2456

Streuung der Lichtstärke in einer Verpackungseinheit $I_{V \max} / I_{V \min} \leq 2.0$.
Luminous intensity ratio in one packaging unit $I_{V \max} / I_{V \min} \leq 2.0$.

Grenzwerte
Maximum Ratings

Bezeichnung Parameter	Symbol Symbol	Werte Values	Einheit Unit
Betriebstemperatur Operating temperature range	T_{op}	- 55 ... + 100	°C
Lagertemperatur Storage temperature range	T_{slg}	- 55 ... + 100	°C
Sperrschichttemperatur Junction temperature	T_j	+ 100	°C
Durchlaßstrom Forward current	I_F	30	mA
Stoßstrom Surge current $t \leq 10 \mu s, D = 0.005$	I_{FM}	0.5	A
Sperrspannung Reverse voltage	V_R	5	V
Verlustleistung Power dissipation	P_{tot}	100	mW
Wärmewiderstand Thermal resistance Sperrschicht / Umgebung Junction / air Montage auf PC-board*) (Padgröße $\geq 16 \text{ mm}^2$) mounted on PC board*) (pad size $\geq 16 \text{ mm}^2$)	$R_{th JA}$	400	K/W

*) PC-board: FR4

Kennwerte ($T_A = 25\text{ °C}$)

Characteristics

Bezeichnung Parameter	Symbol Symbol	Werte Values					Einheit Unit
		LS	LO	LY	LG	LP	
Wellenlänge des emittierten Lichtes Wavelength at peak emission $I_F = 10\text{ mA}$	(typ.) λ_{peak} (typ.)	635	610	586	565	557	nm
Dominantwellenlänge Dominant wavelength $I_F = 10\text{ mA}$	(typ.) λ_{dom} (typ.)	628	605	590	570	560	nm
Spektrale Bandbreite bei 50 % $I_{\text{rel max}}$ Spectral bandwidth at 50 % $I_{\text{rel max}}$ $I_F = 10\text{ mA}$	(typ.) $\Delta\lambda$ (typ.)	45	40	45	25	22	nm
Abstrahlwinkel bei 50 % I_v (Vollwinkel) Viewing angle at 50 % I_v	2φ	120	120	120	120	120	Grad deg.
Durchlaßspannung Forward voltage $I_F = 10\text{ mA}$	(typ.) V_F (max.) V_F	2.0 2.6	2.0 2.6	2.0 2.6	2.0 2.6	2.0 2.6	V V
Sperrstrom Reverse current $V_R = 5\text{ V}$	(typ.) I_R (max.) I_R	0.01 10	0.01 10	0.01 10	0.01 10	0.01 10	μA μA
Kapazität Capacitance $V_R = 0\text{ V}, f = 1\text{ MHz}$	(typ.) C_0	12	8	10	15	15	pF
Schaltzeiten: Switching times:							
I_v from 10 % to 90 % I_v from 90 % to 10 % $I_F = 100\text{ mA}, t_p = 10\text{ }\mu\text{s}, R_L = 50\text{ }\Omega$	(typ.) t_r (typ.) t_f	300 150	300 150	300 150	450 200	450 200	ns ns

Relative spektrale Emission $I_{rel} = f(\lambda)$, $T_A = 25^\circ\text{C}$, $I_F = 10\text{ mA}$

Relative spectral emission

$V(\lambda)$ = spektrale Augenempfindlichkeit
Standard eye response curve

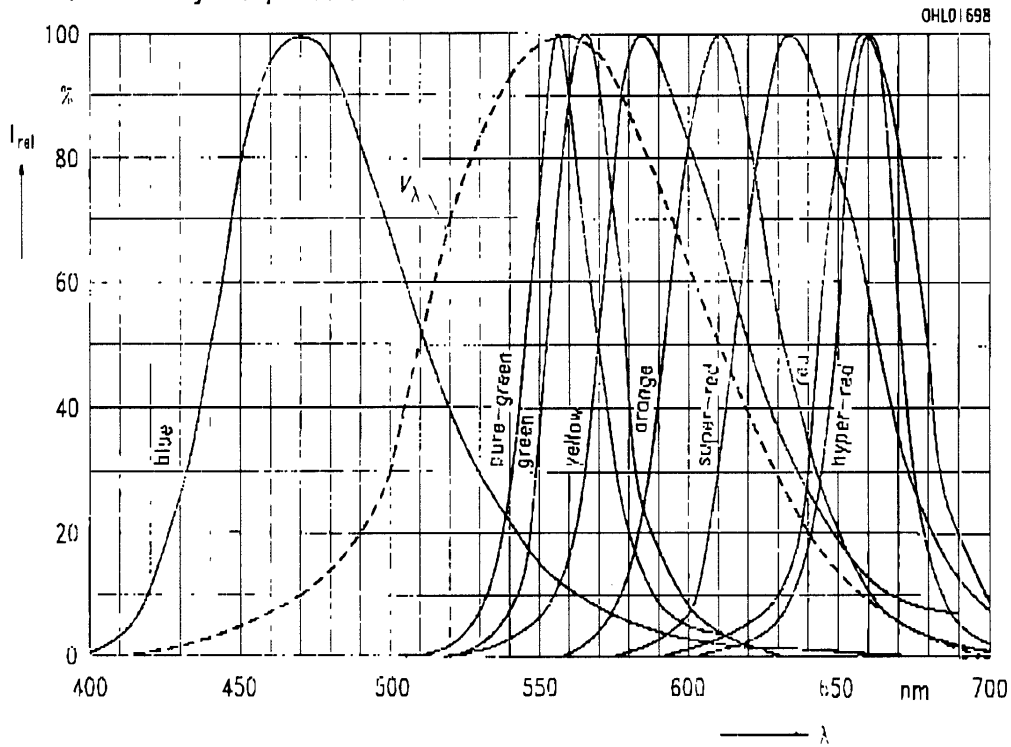

Abstrahlcharakteristik $I_{rel} = f(\varphi)$

Radiation characteristic

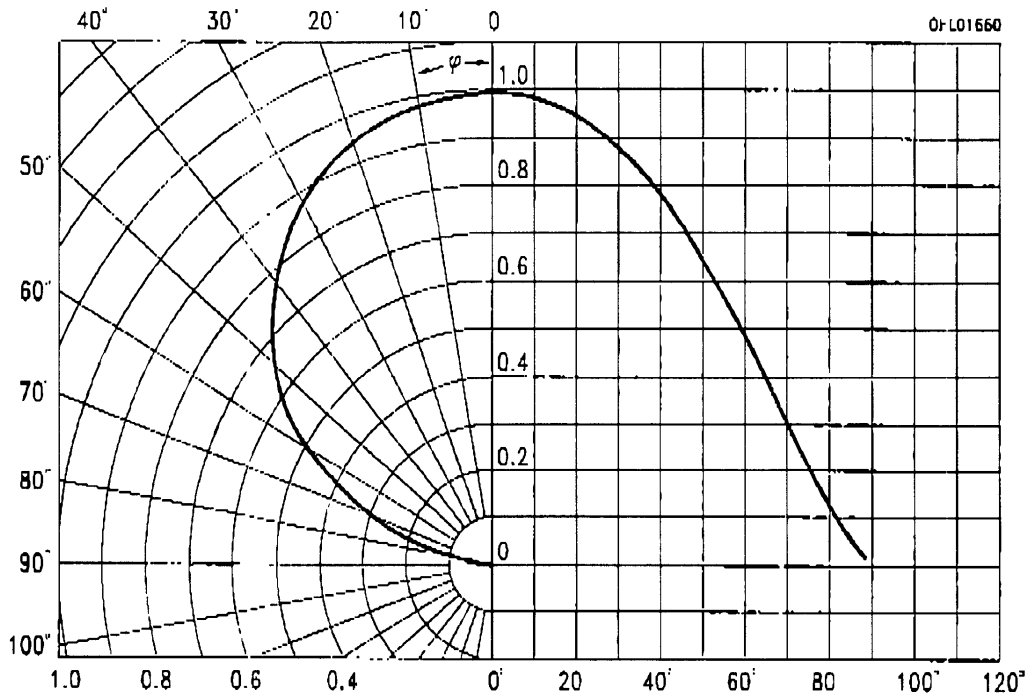

Durchlaßstrom $I_F = f(V_F)$
Forward current
 $T_A = 25^\circ\text{C}$

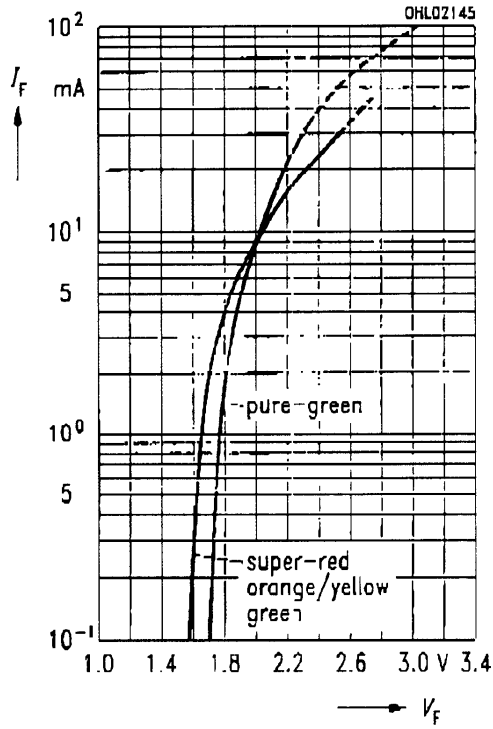

Relative Lichtstärke $I_V/I_{V(10\text{mA})} = f(I_F)$
Relative luminous intensity
 $T_A = 25^\circ\text{C}$

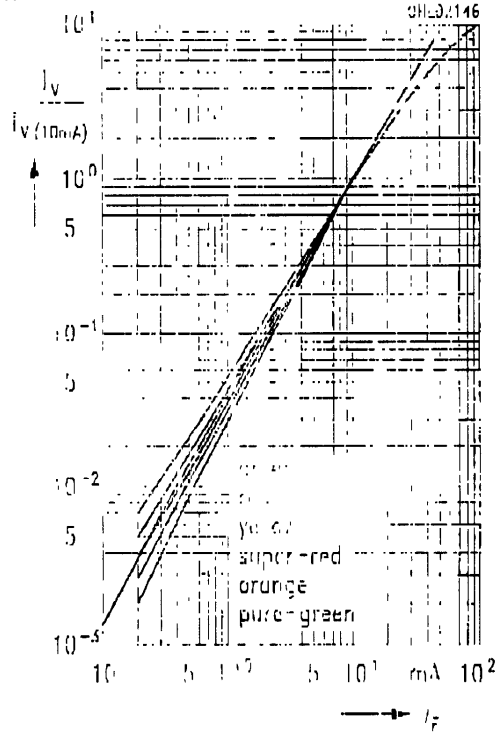

Zulässige Impulsbelastbarkeit $I_F = f(t_p)$
Permissible pulse handling capability
Duty cycle $D = \text{parameter}$, $T_A = 25^\circ\text{C}$

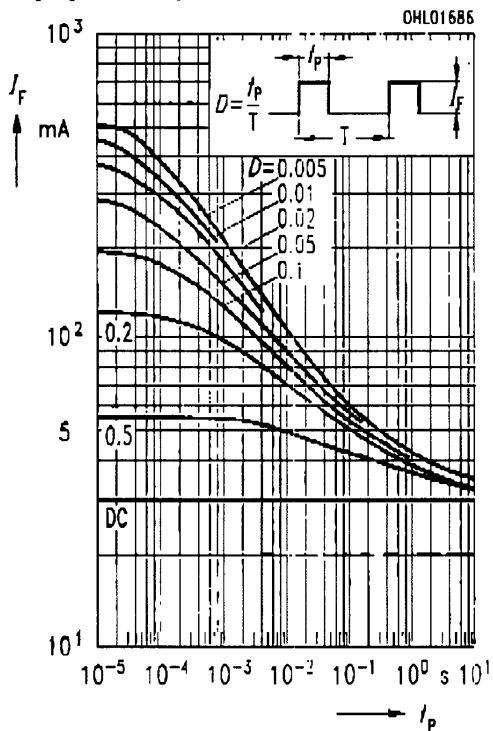

Maximal zulässiger Durchlaßstrom
Max. permissible forward current
 $I_F = f(T_A)$

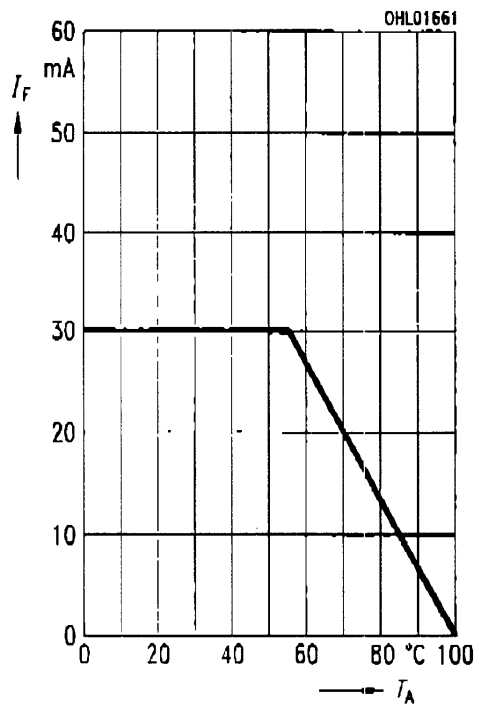

Wellenlänge der Strahlung $\lambda_{\text{peak}} = f(T_A)$
Wavelength at peak emission
 $I_F = 10 \text{ mA}$

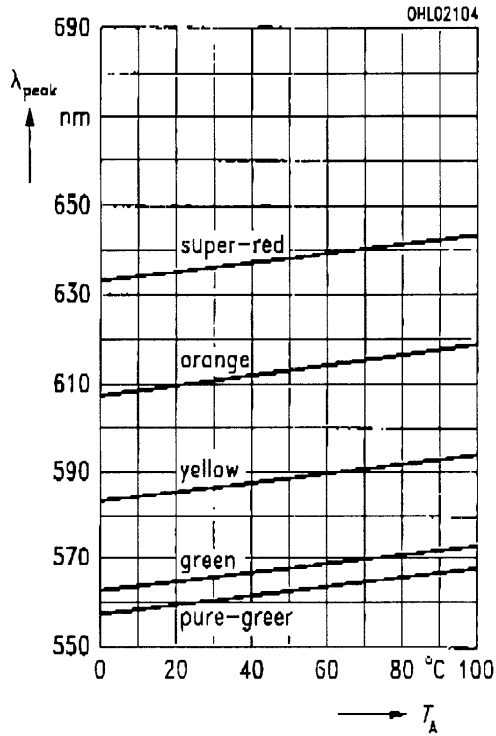

Dominantwellenlänge $\lambda_{\text{dom}} = f(T_A)$
Dominant wavelength
 $I_F = 10 \text{ mA}$

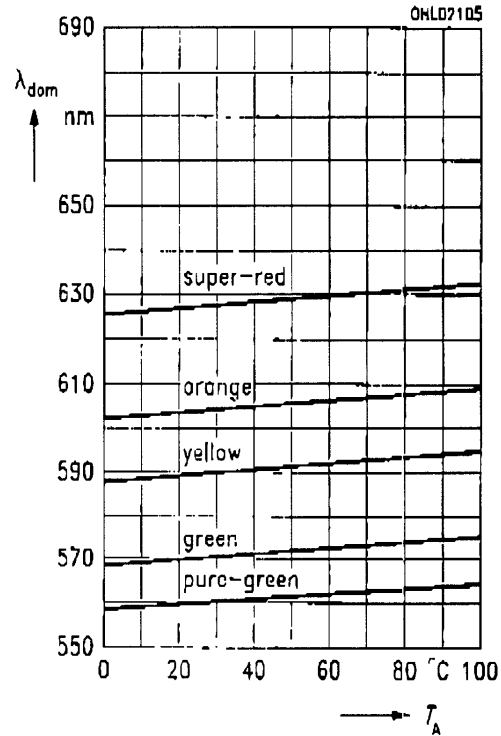

Durchlaßspannung $V_F = f(T_A)$
Forward voltage
 $I_F = 10 \text{ mA}$

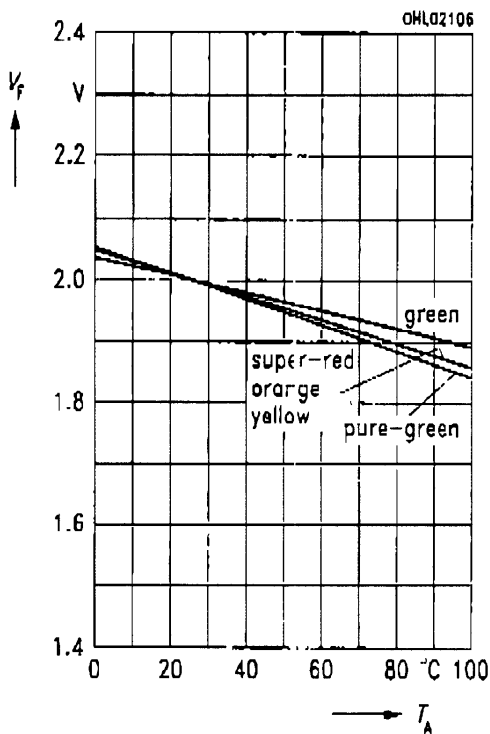

Relative Lichtstärke $I_V / I_{V(25^\circ\text{C})} = f(T_A)$
Relative luminous intensity
 $I_F = 10 \text{ mA}$

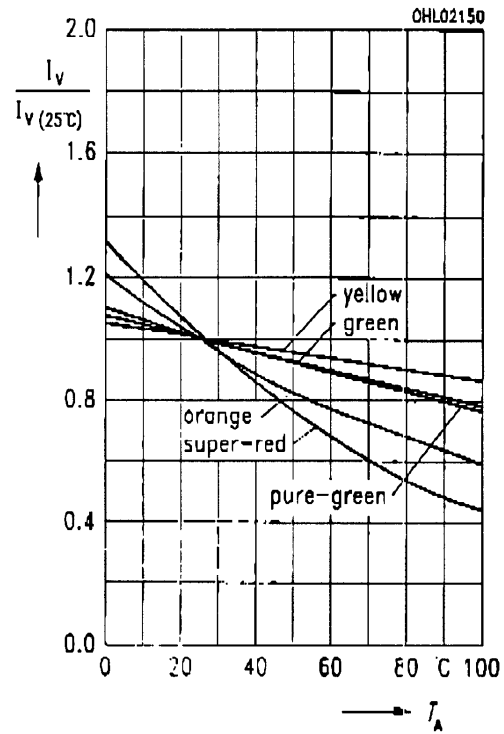

Maßzeichnung (Maße in mm, wenn nicht anders angegeben)
Package Outlines (Dimensions in mm, unless otherwise specified)

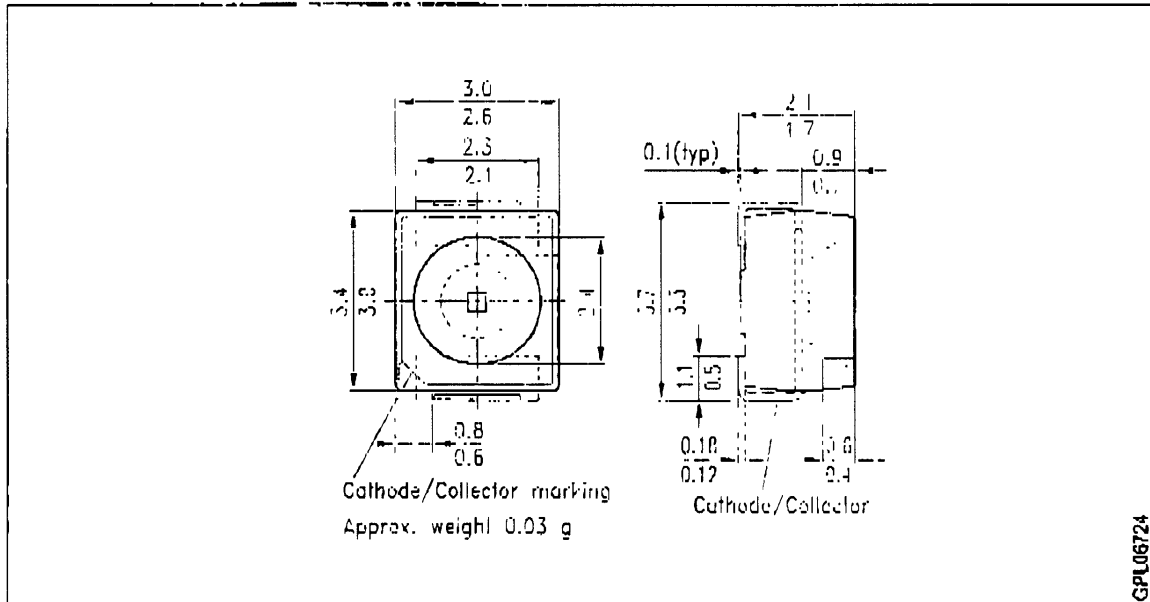

Kathodenkennung: abgeschrägte Ecke
Cathode mark: bevelled edge