



**PI74AVC16646  
PI74AVCH16646**

**16-Bit Bus Transceiver and Register  
with 3-State Outputs**

**Product Features**

- Designed for low voltage operation,  $V_{CC} = 1.65V$  to  $3.6V$
- Sub 2.0ns delays at 2.5V and 3.3V
- Dynamic Impedance Control on outputs, current drive  $> \pm 24mA$  at  $2.5V_{CC}$
- Patented noise reduction circuit
- I/O Tolerant to 3.6V, Inputs and Outputs for mixed voltage systems
- Supports live insertion
- Industrial operation at  $-40^{\circ}C$  to  $+85^{\circ}C$
- Available Packages:
  - 48-pin 240 mil wide plastic TSSOP (A48)
  - 48-pin 173 mil wide plastic TVSOP (K48)

**Product Description**

Pericom Semiconductor’s PI74AVC series of logic circuits are produced using the Company’s advanced 0.35 micron CMOS technology, achieving industry leading speed.

This 16-bit bus transceiver and register can be used as two 8-bit transceivers or one 16-bit transceiver. Data on the A or B bus is clocked into the registers on the low-to-high transition of the appropriate Clock (CLKAB or CLKBA) input. Four fundamental bus-management functions can be performed.

Output Enable ( $\overline{OE}$ ) and Direction Control (DIR) inputs are provided to control the transceiver functions. In the transceiver mode, data present at the high-impedance port may be stored in either register or in both. The Select Control (SAB and SBA) inputs can multiplex stored and real-time (transparent mode) data. Circuitry used for Select Control eliminates the typical decoding glitch that occurs in a multiplexer during the transition between stored and real-time data. DIR determines which bus receives data when  $\overline{OE}$  is LOW. In the isolation mode ( $\overline{OE}$  HIGH), A data may be stored in one register and/or B data may be stored in the other register.

When an output function is disabled, the input function is still enabled and may be used to store and transmit data. Only one of the two buses, A or B, can be driven at a time.

To ensure the high-impedance state during power up or power down,  $\overline{OE}$  should be tied to  $V_{CC}$  through a pullup resistor; the minimum value of the resistor is determined by the current-sinking capability of the driver.

The PI74AVCH16646 has “Bus Hold” which retains the data input’s last state whenever the data input goes to high-impedance preventing “floating” inputs and eliminating the need for pullup/down resistors.

**Logic Block Diagram**

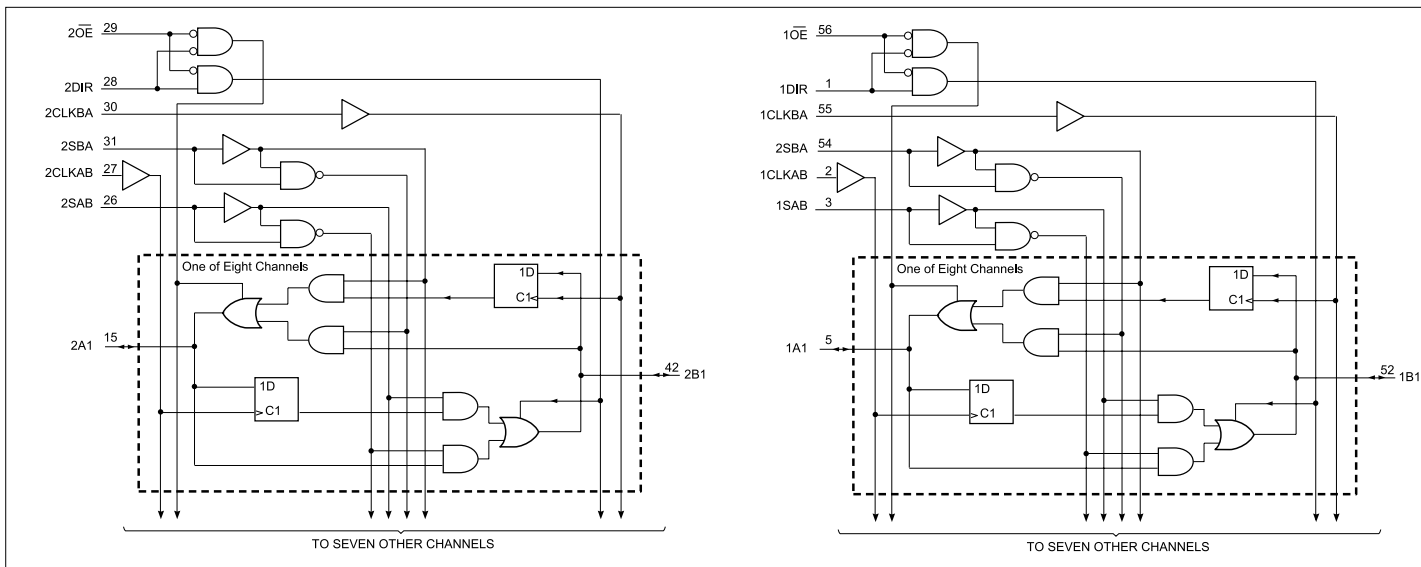

**Product Pin Configuration**

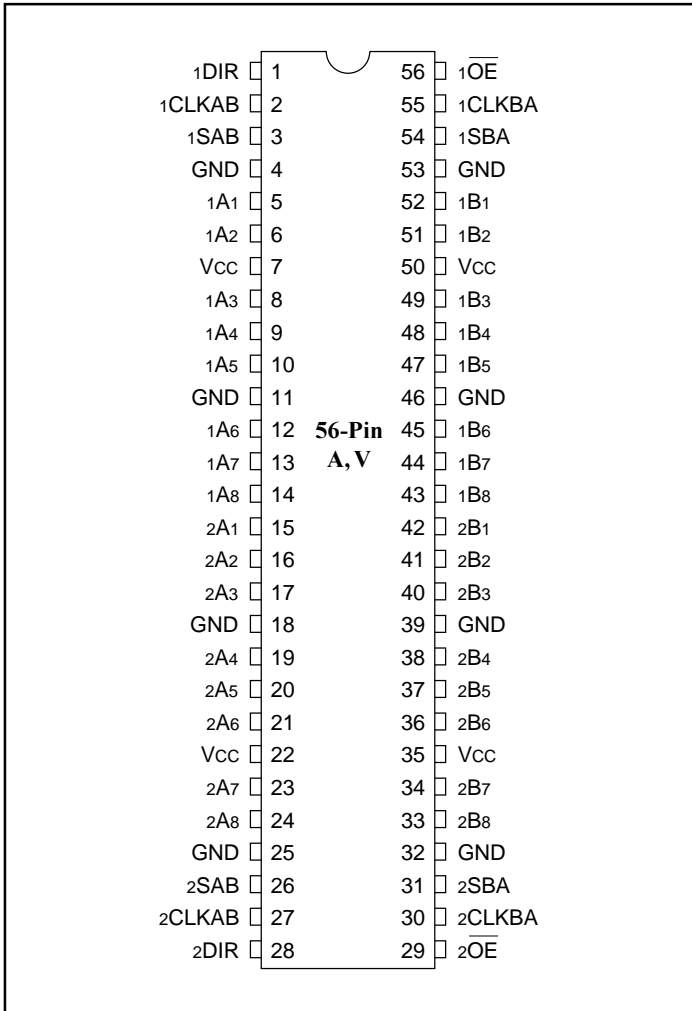

**Product Pin Description**

Pin Name	Description
$\overline{xOE}$	Output Enable Inputs (Active LOW)
xDIR	Direction Control
xCLKAB, xCLKBA	Clock Pulse Inputs
xSAB, xSBA	Select Control Inputs
xAx	Data Register A Inputs Data Register B Outputs
xBx	Data Register B Inputs Data Register A Outputs
GND	Ground
VCC	Power

**Truth Table<sup>(2)</sup>**

Function	Inputs						Data I/O	
	$\overline{xOE}$	xDIR	xCLKAB	xCLKBA	xSAB	xSBA	xAx	xBx
Store A, B Unspecified <sup>(1)</sup>	X	X	↑	X	X	X	Input	Unspecified <sup>(1)</sup>
Store B, A Unspecified <sup>(1)</sup>	X	X	X	↑	X	X	Unspecified <sup>(1)</sup>	Input
Isolation	H	X	H or L	H or L	X	X	Input Disable	Input Disable
Store A and B Data	H	X	↑	↑	X	X	Input	Input
Real Time A Data to B Bus	L	H	X	X	L	X	Input	Output
Stored A Data to B Bus	L	H	H or L	X	H	X	Input	Output
Real Time B Data to A Bus	L	L	X	X	X	L	Output	Input
Stored B Data to A Bus	L	L	X	H or L	X	H	Output	Input

**Note:**

- The data output functions may be enabled or disabled by various signals at the  $\overline{xOE}$  or xDIR inputs. Data input functions are always enabled, i.e., data at the bus pins will be stored on every LOW-to-HIGH transition on the clock inputs.
- H = High Voltage Level  
X = Don't Care  
L = Low Voltage Level  
↑ = LOW-to-HIGH Transition

**REAL-TIME TRANSFER  
BUS B TO A**

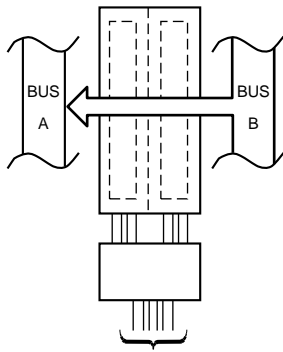

xDIR	$\overline{\text{xOE}}$	xCLKAB	xCLKBA	xSAB	xSBA
L	L	X	X	X	L

**REAL-TIME TRANSFER  
BUS A TO B**

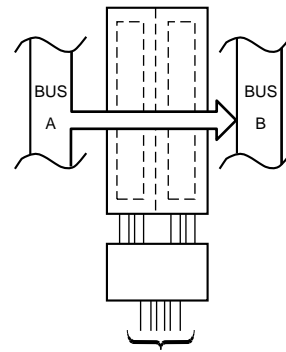

xDIR	$\overline{\text{xOE}}$	xCLKAB	xCLKBA	xSAB	xSBA
H	L	X	X	L	X

**STORAGE FROM  
A AND/OR B**

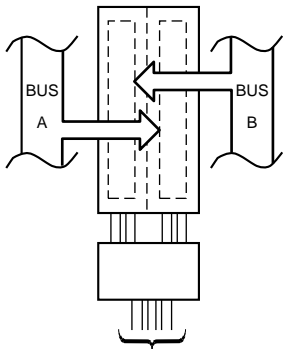

xDIR	$\overline{\text{xOE}}$	xCLKAB	xCLKBA	xSAB	xSBA
X	X	↑	X	X	X
X	X	X	↑	X	X
X	H	↑	↑	X	X

**TRANSFER STORES  
DATA TO A AND/OR B**

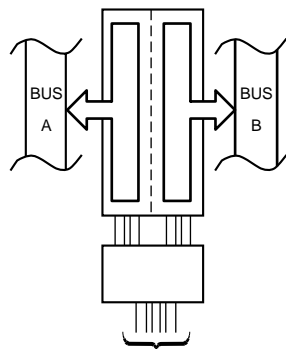

xDIR <sup>(1)</sup>	$\overline{\text{xOE}}$	xCLKAB	xCLKBA	xSAB	xSBA
L	L	X	H or L	X	H
H	L	H or L	X	H	X

**Note:**

1. Cannot transfer data to A bus and B bus simultaneously.



**Maximum Ratings**

(Above which the useful life may be impaired. For user guidelines, not tested.)

Storage Temperature .....	-65°C to +150°C
Ambient Temperature with Power Applied .....	-40°C to +85°C
Input Voltage Range, $V_{IN}$ .....	-0.5V to $V_{CC} + 4.6V$
Output Voltage Range, $V_{OUT}$ .....	-0.5V to $V_{CC} + 0.5V$
DC Input Voltage .....	-0.5V to +5.0V
DC Output Current .....	50 mA
Power Dissipation .....	1.0W

**Note:**

Stresses greater than those listed under MAXIMUM RATINGS may cause permanent damage to the device. This is a stress rating only and functional operation of the device at these or any other conditions above those indicated in the operational sections of this specification is not implied. Exposure to absolute maximum rating conditions for extended periods may affect reliability.

**DC Electrical Characteristics** (Over the Operating Range,  $T_A = -40^\circ\text{C}$  to  $+85^\circ\text{C}$ ,  $V_{CC} = 3.3V \pm 10\%$ )

Parameters	Description	Test Conditions <sup>(1)</sup>	Min.	Typ. <sup>(2)</sup>	Max.	Units
$V_{CC}$	Supply Voltage		2.3		3.6	
$V_{IH}^{(3)}$	Input HIGH Voltage	$V_{CC} = 2.3V$ to $2.7V$	1.7			
		$V_{CC} = 2.7V$ to $3.6V$	2.0			
$V_{IL}^{(3)}$	Input LOW Voltage	$V_{CC} = 2.3V$ to $2.7V$			0.7	
		$V_{CC} = 2.7V$ to $3.6V$			0.8	
$V_{IN}^{(3)}$	Input Voltage		0		$V_{CC}$	
$V_{OUT}^{(3)}$	Output Voltage		0		$V_{CC}$	
$V_{OH}$	Output HIGH Voltage	$I_{OH} = -100\mu A$ , $V_{CC} = \text{Min. to Max.}$	$V_{CC} - 0.2$			
		$V_{IH} = 1.7V$ , $I_{OH} = -6mA$ , $V_{CC} = 2.3V$	2.0			
		$V_{IH} = 1.7V$ , $I_{OH} = -12mA$ , $V_{CC} = 2.3V$	1.7			
		$V_{IH} = 2.0V$ , $I_{OH} = -12mA$ , $V_{CC} = 2.7V$	2.2			
		$V_{IH} = 2.0V$ , $I_{OH} = -12mA$ , $V_{CC} = 3.0V$	2.4			
		$V_{IH} = 2.0V$ , $I_{OH} = -24mA$ , $V_{CC} = 3.0V$	2.0			
$V_{OL}$	Output LOW Voltage	$I_{OL} = 100\mu A$ , $V_{IL} = \text{Min. to Max.}$			0.2	
		$V_{IL} = 0.7V$ , $I_{OL} = 6mA$ , $V_{CC} = 2.3V$			0.4	
		$V_{IL} = 0.7V$ , $I_{OL} = 12mA$ , $V_{CC} = 2.3V$			0.7	
		$V_{IL} = 0.8V$ , $I_{OL} = 12mA$ , $V_{CC} = 2.7V$			0.4	
		$V_{IL} = 0.8V$ , $I_{OL} = 24mA$ , $V_{CC} = 3.0V$			0.55	
$I_{OH}^{(3)}$	Output HIGH Current	$V_{CC} = 2.3V$			-12	
		$V_{CC} = 2.7V$			-12	
		$V_{CC} = 3.0V$			-24	
$I_{OL}^{(3)}$	Output LOW Current	$V_{CC} = 2.3V$			12	
		$V_{CC} = 2.7V$			12	
		$V_{CC} = 3.0V$			24	



## ADVANCE INFORMATION

PI74AVC16646/PI74AVCH16646  
16-Bit Bus Transceiver and Register  
with 3-State Outputs

### DC Electrical Characteristics-Continued (Over the Operating Range, $T_A = -40^\circ\text{C}$ to $+85^\circ\text{C}$ , $V_{CC} = 3.3\text{V} \pm 10\%$ )

Parameters	Description	Test Conditions <sup>(1)</sup>	Min.	Typ. <sup>(2)</sup>	Max.	Units
$I_{IN}$	Input Current	$V_{IN} = V_{CC}$ or GND, $V_{CC} = 3.6\text{V}$			$\pm 5$	$\mu\text{A}$
$I_{IN (HOLD)}$	Input Hold Current	$V_{IN} = 0.7\text{V}$ , $V_{CC} = 2.3\text{V}$	45			
		$V_{IN} = 1.7\text{V}$ , $V_{CC} = 2.3\text{V}$	-45			
		$V_{IN} = 0.8\text{V}$ , $V_{CC} = 3.0\text{V}$	75			
		$V_{IN} = 2.0\text{V}$ , $V_{CC} = 3.0\text{V}$	-75			
		$V_{IN} = 0$ to $3.6\text{V}$ , $V_{CC} = 3.6\text{V}$			$\pm 500$	
$I_{OZ}$	Output Current (3-STATE Outputs)	$V_{OUT} = V_{CC}$ or GND, $V_{CC} = 3.6\text{V}$			$\pm 10$	
$I_{CC}$	Supply Current	$V_{CC} = 3.6\text{V}$ , $I_{OUT} = 0\mu\text{A}$ , $V_{IN} = \text{GND}$ or $V_{CC}$			40	
$\Delta I_{CC}$	Supply Current per Input @ TTL HIGH	$V_{CC} = 3.0\text{V}$ to $3.6\text{V}$ One Input at $V_{CC} - 0.6\text{V}$ Other Inputs at $V_{CC}$ or GND			750	
$C_I$	Control Inputs	$V_{IN} = V_{CC}$ or GND, $V_{CC} = 3.3\text{V}$		3		pF
	Data Inputs			6		
$C_O$	Outputs	$V_O = V_{CC}$ or GND, $V_{CC} = 3.3\text{V}$		7		

#### Notes:

- For conditions shown as Max. or Min., use appropriate value specified under Electrical Characteristics for the applicable device type.
- Typical values are at  $V_{CC} = 3.3\text{V}$ ,  $+25^\circ\text{C}$  ambient and maximum loading.
- Unused Control Inputs must be held HIGH or LOW to prevent them from floating.

### Timing Requirements

Parameters	Description		Conditions <sup>(1)</sup>	$V_{CC} = 2.5\text{V} \pm 0.2\text{V}$		$V_{CC} = 2.7\text{V}$		$V_{CC} = 3.3\text{V} \pm 0.3\text{V}$		Units
				Min. <sup>(2)</sup>	Max.	Min. <sup>(2)</sup>	Max.	Min. <sup>(2)</sup>	Max.	
$f_{CLOCK}$	Clock Frequency		$C_L = 50\text{pF}$ $R_L = 500\Omega$	0	150	0	150	0	150	MHz
$t_W$	Pulse Duration	CLKAB or CLKBA HIGH or LOW		3.3		3.3		3.3		ns
$t_{SU}$	Setup Time	A Before CLKAB $\uparrow$ or B Before CLKBA $\uparrow$		1.6		1.7		1.4		
$t_H$	Hold Time	A After CLKAB $\uparrow$ or B After CLKBA $\uparrow$		0.6		0.4		0.7		



**Switching Characteristics over Operating Range<sup>(1)</sup>**

Parameters	From (INPUT)	To (OUTPUT)	Conditions <sup>(1)</sup>	V <sub>CC</sub> = 2.5V ±0.2V		V <sub>CC</sub> = 2.7V		V <sub>CC</sub> = 3.3V ±0.3V		Units			
				Min. <sup>(2)</sup>	Max.	Min. <sup>(2)</sup>	Max.	Min. <sup>(2)</sup>	Max.				
f <sub>MAX</sub>			C <sub>L</sub> = 50pF R <sub>L</sub> = 500Ω	150		150		150		MHz			
t <sub>PD</sub>	A or B	B or A		1.0		4.8		4.5	1.0		ns		
t <sub>PD</sub>	CLKAB or CLKBA	A or B				5.6		5.2				3.9	
t <sub>PD</sub>	SAB or SBA					6.8		6.4				4.5	
t <sub>EN</sub>	OE					6.5		6.2				5.3	
t <sub>DIS</sub>	OE					1.8	5.7			5.0		1.4	4.7
t <sub>EN</sub>	DIR					1.0	7.8			6.2		1.0	5.1
t <sub>DIS</sub>	DIR					1.7	6.5			6.0		1.1	5.3
<b>Description</b>													
Δt/Δv <sup>(3)</sup>	Input Transition Rise or Fall			0	10	0	10	0	10	ns/V			

**Notes:**

1. See test circuit and waveforms.
2. Minimum limits are guaranteed but not tested on Propagation Delays.
3. Recommended operating condition.

**Operating Characteristics, T<sub>A</sub> = 25°C**

Parameter		Test Conditions	V <sub>CC</sub> = 2.5V ±0.2V	V <sub>CC</sub> = 3.3V ±0.3V	Units
			Typ.		
C <sub>PD</sub> Power Dissipation Capacitance	Outputs Enabled	C <sub>L</sub> = 50pF, f = 10 MHz	39	43	pF
	Outputs Disabled		10	12	