



NATL SEMICON (LINEAR)

F79-06-10

LM108/LM208/LM308

LM108/LM208/LM308 Operational Amplifiers

General Description

The LM108 series are precision operational amplifiers having specifications a factor of ten better than FET amplifiers over a -55°C to $+125^{\circ}\text{C}$ temperature range.

The devices operate with supply voltages from $\pm 2\text{V}$ to $\pm 20\text{V}$ and have sufficient supply rejection to use unregulated supplies. Although the circuit is interchangeable with and uses the same compensation as the LM101A, an alternate compensation scheme can be used to make it particularly insensitive to power supply noise and to make supply bypass capacitors unnecessary.

The low current error of the LM108 series makes possible many designs that are not practical with conventional amplifiers. In fact, it operates from $10\text{ M}\Omega$ source resistances,

introducing less error than devices like the 709 with $10\text{ k}\Omega$ sources. Integrators with drifts less than $500\ \mu\text{V}/\text{sec}$ and analog time delays in excess of one hour can be made using capacitors no larger than $1\ \mu\text{F}$.

The LM108 is guaranteed from -55°C to $+125^{\circ}\text{C}$, the LM208 from -25°C to $+85^{\circ}\text{C}$, and the LM308 from 0°C to $+70^{\circ}\text{C}$.

Features

- Maximum input bias current of $3.0\ \text{nA}$ over temperature
- Offset current less than $400\ \text{pA}$ over temperature
- Supply current of only $300\ \mu\text{A}$, even in saturation
- Guaranteed drift characteristics

Compensation Circuits

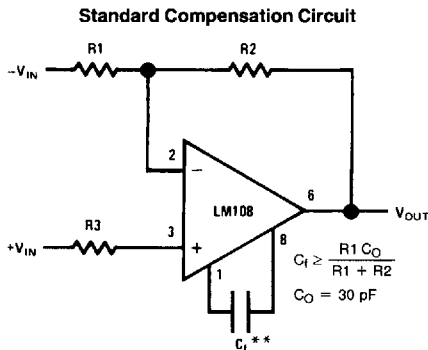

TL/H/7758-1

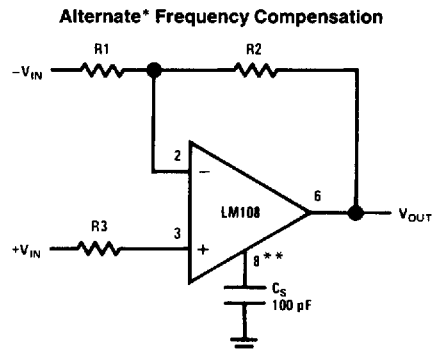
**Bandwidth and slew rate are proportional to $1/C_1$ 

TL/H/7758-2

*Improves rejection of power supply noise by a factor of ten.

**Bandwidth and slew rate are proportional to $1/C_S$

Feedforward Compensation

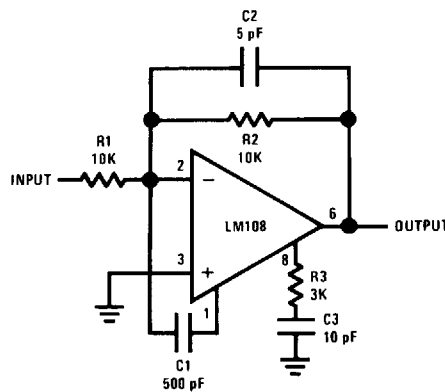

TL/H/7758-3

Absolute Maximum Ratings

If Military/Aerospace specified devices are required, please contact the National Semiconductor Sales Office/Distributors for availability and specifications.
(Note 5)

	LM108/LM208	LM308
Supply Voltage	±20V	±18V
Power Dissipation (Note 1)	500 mW	500 mW
Differential Input Current (Note 2)	±10 mA	±10 mA
Input Voltage (Note 3)	±15V	±15V
Output Short-Circuit Duration	Continuous	Continuous
Operating Temperature Range (LM108)	-55°C to +125°C	0°C to +70°C
(LM208)	-25°C to +85°C	
Storage Temperature Range	-65°C to +150°C	-65°C to +150°C
Lead Temperature (Soldering, 10 sec)		
DIP	260°C	260°C
H Package Lead Temp (Soldering 10 seconds)	300°C	300°C
Soldering Information		
Dual-In-Line Package		
Soldering (10 seconds)	260°C	
Small Outline Package		
Vapor Phase (60 seconds)	215°C	
Infrared (15 seconds)	220°C	
See AN-450 "Surface Mounting Methods and Their Effect on Product Reliability" for other methods of soldering surface mount devices.		
ESD Tolerance (Note 6)	2000V	

Electrical Characteristics (Note 4)

Parameter	Condition	LM108/LM208			LM308			Units
		Min	Typ	Max	Min	Typ	Max	
Input Offset Voltage	$T_A = 25^\circ\text{C}$		0.7	2.0		2.0	7.5	mV
Input Offset Current	$T_A = 25^\circ\text{C}$		0.05	0.2		0.2	1	nA
Input Bias Current	$T_A = 25^\circ\text{C}$		0.8	2.0		1.5	7	nA
Input Resistance	$T_A = 25^\circ\text{C}$	30	70		10	40		MΩ
Supply Current	$T_A = 25^\circ\text{C}$		0.3	0.6		0.3	0.8	mA
Large Signal Voltage Gain	$T_A = 25^\circ\text{C}, V_S = \pm 15\text{V}$ $V_{OUT} = \pm 10\text{V}, R_L \geq 10\text{ k}\Omega$	50	300		25	300		V/mV
Input Offset Voltage				3.0			10	mV
Average Temperature Coefficient of Input Offset Voltage			3.0	15		6.0	30	$\mu\text{V}/^\circ\text{C}$
Input Offset Current				0.4			1.5	nA
Average Temperature Coefficient of Input Offset Current			0.5	2.5		2.0	10	$\text{pA}/^\circ\text{C}$
Input Bias Current				3.0			10	nA
Supply Current	$T_A = +125^\circ\text{C}$		0.15	0.4				mA
Large Signal Voltage Gain	$V_S = \pm 15\text{V}, V_{OUT} = \pm 10\text{V}$ $R_L \geq 10\text{ k}\Omega$	25			15			V/mV
Output Voltage Swing	$V_S = \pm 15\text{V}, R_L = 10\text{ k}\Omega$	±13	±14		±13	±14		V

Electrical Characteristics (Note 4) (Continued)

Parameter	Condition	LM108/LM208			LM308			Units
		Min	Typ	Max	Min	Typ	Max	
Input Voltage Range	$V_S = \pm 15V$	± 13.5			± 14			V
Common Mode Rejection Ratio		85	100		80	100		dB
Supply Voltage Rejection Ratio		80	96		80	96		dB

Note 1: The maximum junction temperature of the LM108 is 150°C, for the LM208, 100°C and for the LM308, 85°C. For operating at elevated temperatures, devices in the H08 package must be derated based on a thermal resistance of 180°C/W, junction to ambient, or 20°C/W, junction to case. The thermal resistance of the dual-in-line package is 100°C/W, junction to ambient.

Note 2: The inputs are shunted with back-to-back diodes for overvoltage protection. Therefore, excessive current will flow if a differential input voltage in excess of 1V is applied between the inputs unless some limiting resistance is used.

Note 3: For supply voltages less than $\pm 15V$, the absolute maximum input voltage is equal to the supply voltage.

Note 4: These specifications apply for $\pm 5V \leq V_S \leq \pm 20V$ and $-55^\circ C \leq T_A \leq +125^\circ C$, unless otherwise specified. With the LM208, however, all temperature specifications are limited to $-25^\circ C \leq T_A \leq 85^\circ C$, and for the LM308 they are limited to $0^\circ C \leq T_A \leq 70^\circ C$.

Note 5: Refer to RETS108X for LM108 military specifications and RETs 108AX for LM108A military specifications.

Note 6: Human body model, 1.5 kΩ in series with 100 pF.

Schematic Diagram

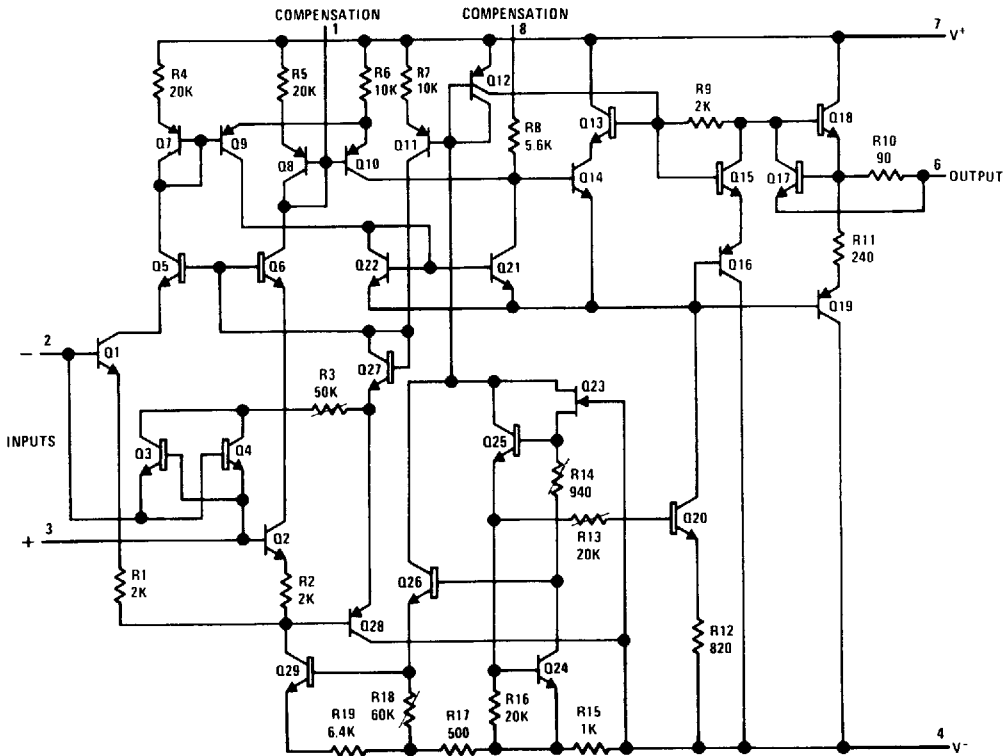

TL/H/7758-8

Typical Performance Characteristics LM108/LM208

LM108/LM208/LM308

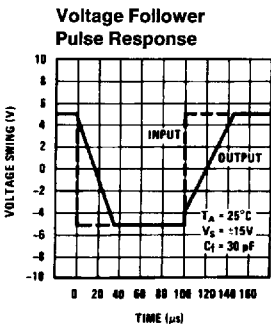
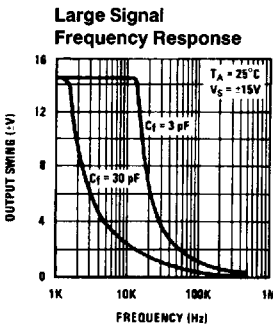
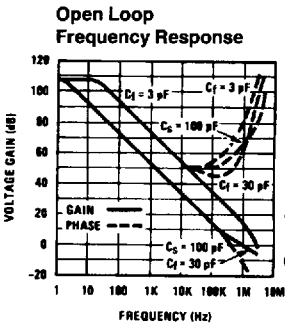
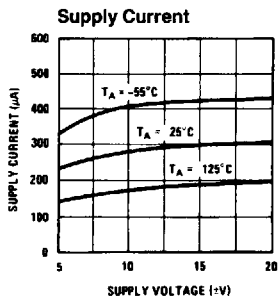
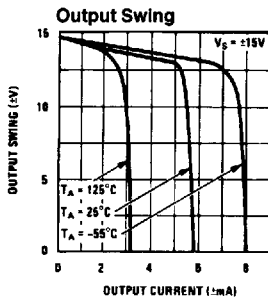
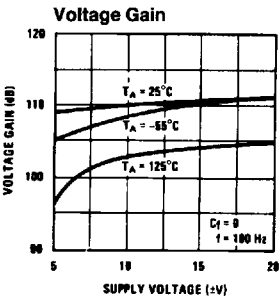
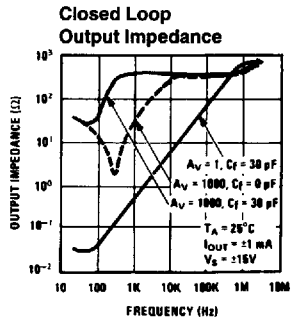
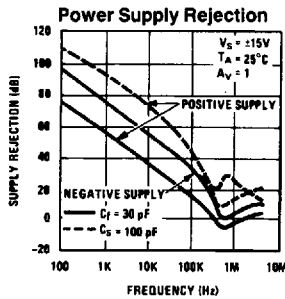
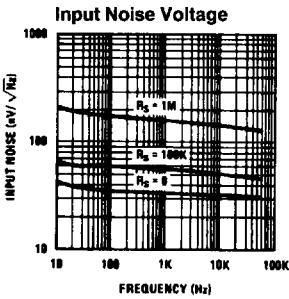
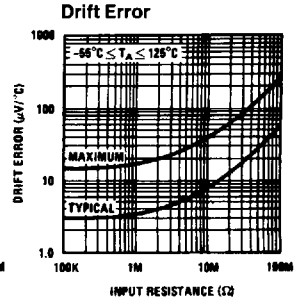
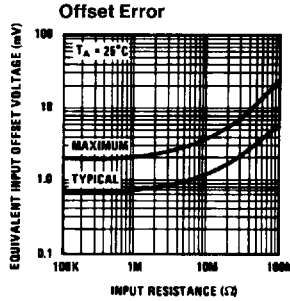
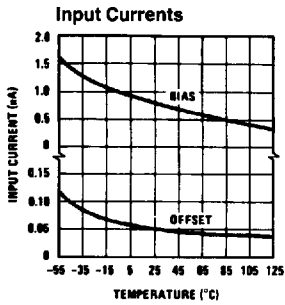

Typical Performance Characteristics LM308

NATL SEMICOND (LINEAR)

LM108/LM208/LM308

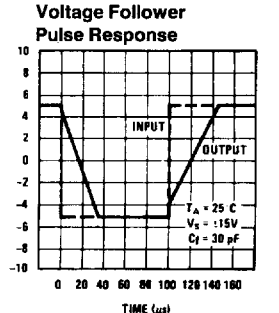
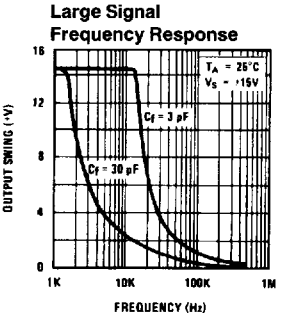
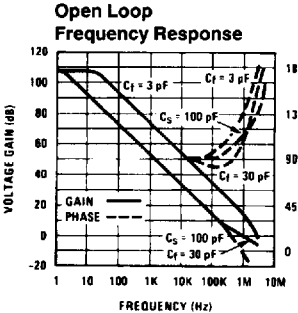
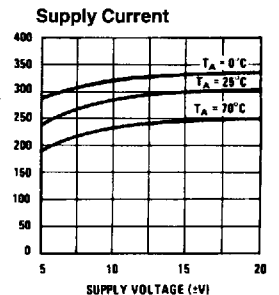
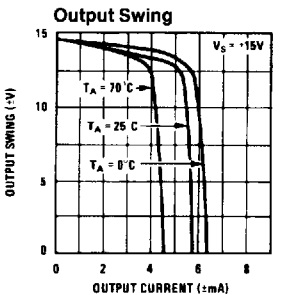
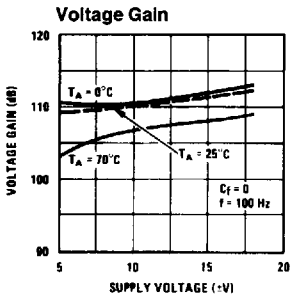
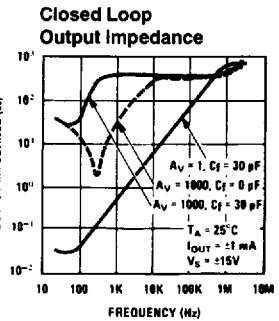
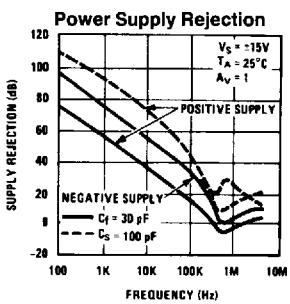
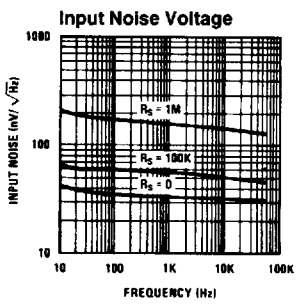
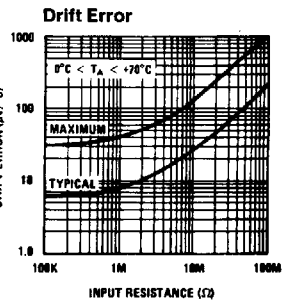
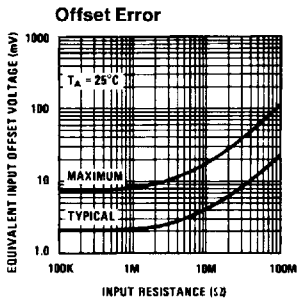
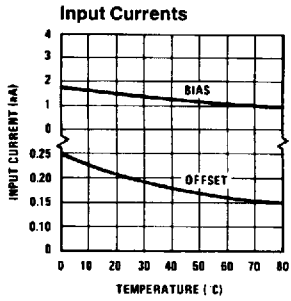

1

TL/H/7758-7

Typical Applications

LM108/LM208/LM308

Sample and Hold

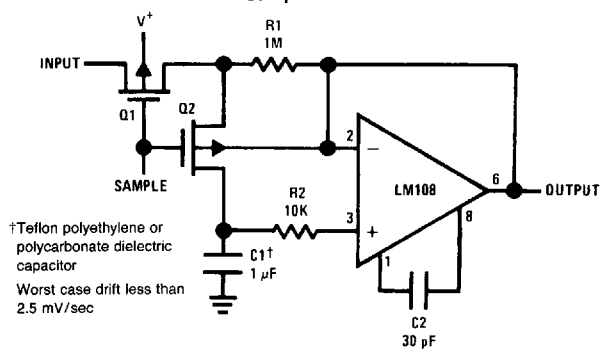

High Speed Amplifier with Low Drift and Low Input Current

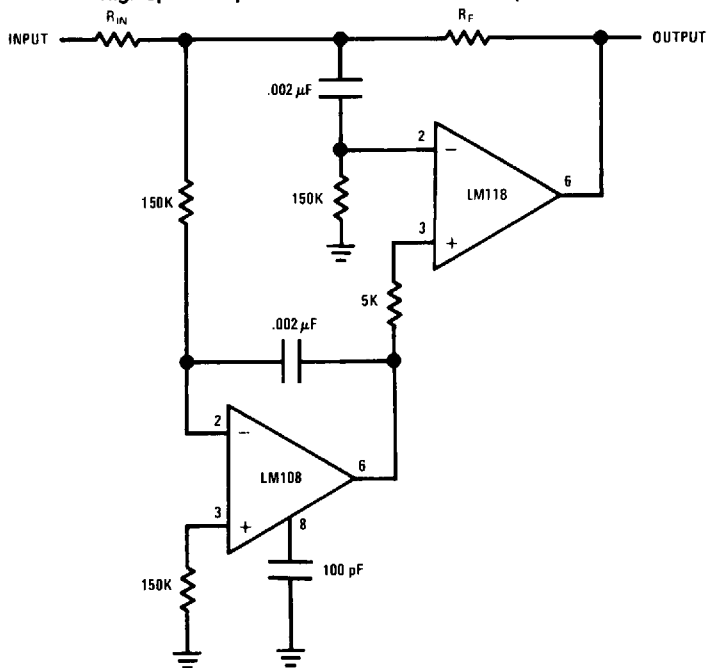

NATL SEMICON (LINEAR)

Typical Applications (Continued)

Fast† Summing Amplifier

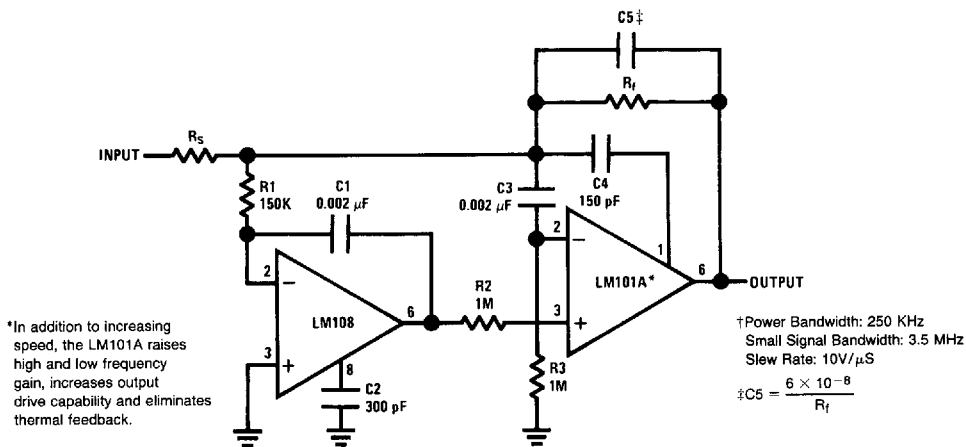

TL/H/7758-12

Connection Diagrams

Metal Can Package

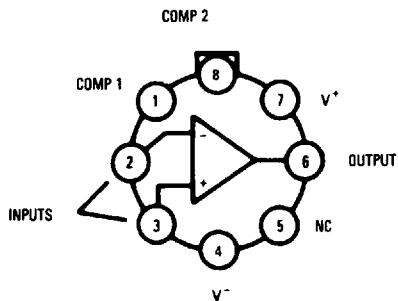

TL/H/7758-13

Dual-In-Line Package

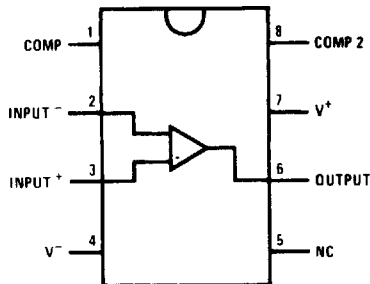

TL/H/7758-15

Top View

Order Number LM108J-8, LM108AJ-8/883†, LM108J-8/883, LM308J-8, LM308M or LM308N See NS Package Number J08A, M08A or N08E

*Package is connected to Pin 4 (V-)

**Unused pin (no internal connection) to allow for input anti-leakage guard ring on printed circuit board layout.

Order Number LM108H, LM108AH/883†, LM108H/883, LM208H, LM308AH or LM308H See NS Package Number H08C

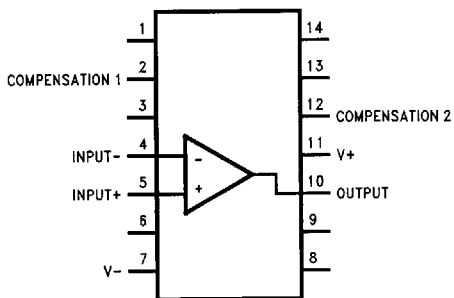

TL/H/7758-16

Top View

Order Number LM108AJ/883† or LM108J/883 See NS Package Number J14A

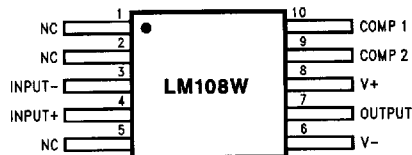

TL/H/7758-17

Order Number LM108AW/883† or LM108W/883 See NS Package Number W10A

†Also available per JM38510/10104

LM108/LM208/LM308

1