

STRUCTURE Silicon Monolithic Integrated Circuit  
 PRODUCT NAME 1ch DC/DC Converter IC built in FET with synchronous rectifier  
 TYPE **BD9131MUV**  
 FEATURES • Output Voltage : Adjustable(0.8~2.5 V), Output Current : 3.0A  
 • High Efficiency and Fast Transient Response

○ABSOLUTE MAXIMUM RATING (Ta=25°C)

Parameter	Symbol	Limit	Unit
Vcc Voltage	VCC	-0.3~+7 * <sup>1</sup>	V
PVcc Voltage	PVCC	-0.3~+7 * <sup>1</sup>	V
BST Voltage	VBST	-0.3~+13	V
BST-SW Voltage	VBST-SW	-0.3~+7	V
EN Voltage	VEN	-0.3~+7	V
Power Dissipation 1	Pd1	0.34 * <sup>2</sup>	W
Power Dissipation 2	Pd2	0.70 * <sup>3</sup>	W
Power Dissipation 3	Pd3	1.21 * <sup>4</sup>	W
Power Dissipation 4	Pd4	3.56 * <sup>5</sup>	W
Operating Temperature Range	Topr	-40~+105	°C
Storage Temperature Range	Tstg	-55~+150	°C
Operating Junction Temperature	Tj	-40~+150	°C

\*<sup>1</sup> Pd and Tj=150°C should not be exceeded.

\*<sup>2</sup> IC only.

\*<sup>3</sup> 1 layer, mounted on a board 74.2mm×74.2mm×1.6mm Glass-epoxy PCB (Copper foil area : 10.29mm<sup>2</sup>)

\*<sup>4</sup> 4 layers, mounted on a board 74.2mm×74.2mm×1.6mm Glass-epoxy PCB (Copper foil area : 10.29mm<sup>2</sup>), copper foil in each layers.

\*<sup>5</sup> 4 layers, mounted on a board 74.2mm×74.2mm×1.6mm Glass-epoxy PCB (Copper foil area : 5505mm<sup>2</sup>), copper foil in each layers.

○OPERATING CONDITIONS (Ta=-40~+105°C)

Parameter	Symbol	Min.	Typ.	Max.	Unit
Vcc Voltage	VCC	2.7	3.3	5.5	V
PVcc Voltage	PVCC	2.7	3.3	5.5	V
EN Voltage	VEN	0	-	5.5	V
Output Voltage range	VOUT	0.8	-	2.5* <sup>6</sup>	V
SW Average Output Current	ISW	-	-	3.0* <sup>7</sup>	A

\*<sup>6</sup> In case set output voltage 1.6V or more, VccMin.=VOUT+1.2V.

\*<sup>7</sup> Pd should not be exceeded.

The product described in this specification is a strategic product (and/or Service) subject to COCOM regulations. It should not be exported without Authorization from the appropriate government.

This product is not designed for protection against radioactive rays.

Status of this document

The Japanese version of this document is the formal specification. A customer may use this translation version only for a reference to help reading the formal version. If there are any differences in translation version of this document, formal version takes priority.

○ ELECTRICAL CHARACTERISTICS

(Unless otherwise specified, Ta=25°C Vcc=PVcc=3.3V, EN=Vcc, R1=10kΩ, R2=5kΩ)

Parameter	Symbol	Limit			Unit	Condition
		Min.	Typ.	Max.		
Standby Current	ISTB	-	0	10	μA	EN=GND
Bias Current	ICC	-	250	500	μA	
EN Low Voltage	VENL	-	GND	0.8	V	Stand-by Mode
EN High Voltage	VENH	2.0	Vcc	-	V	Active Mode
EN Input Current	IEN	-	1	10	μA	VEN=3.3V
Oscillation Frequency	FOSC	0.8	1	1.2	MHz	
Highside FET ON Resistance	RONH	-	82	115	mΩ	PVcc=3.3V
Lowside FET ON Resistance	RONL	-	70	98	mΩ	PVcc=3.3V
ADJ Reference Voltage	VADJ	0.788	0.800	0.812	V	
ITH Sink Current	ITHSI	10	18	-	μA	VADJ=1V
ITH Source Current	ITHSO	10	18	-	μA	VADJ=0.6V
UVLO Threshold Voltage	VUVLO1	2.400	2.500	2.600	V	Vcc=3.3V→0V
UVLO Release Voltage	VUVLO2	2.425	2.550	2.700	V	Vcc=0V→3.3V
Soft Start Time	TSS	2.5	5	10	ms	
Timer Latch Time	TLATCH	0.5	1	2	ms	
Output Short circuit Threshold Voltage	VSCP	-	0.40	0.56	V	VADJ=0.8V→0V

○ PHYSICAL DIMENSION

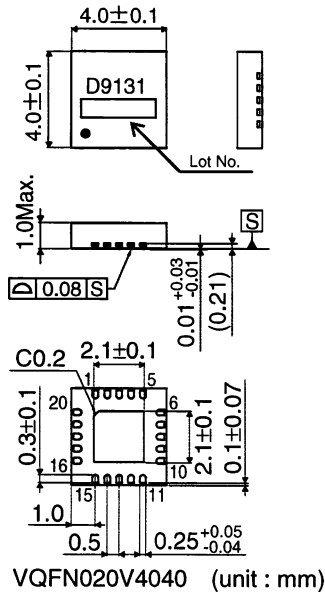

○ BLOCK DIAGRAM • APPLICATION CIRCUIT

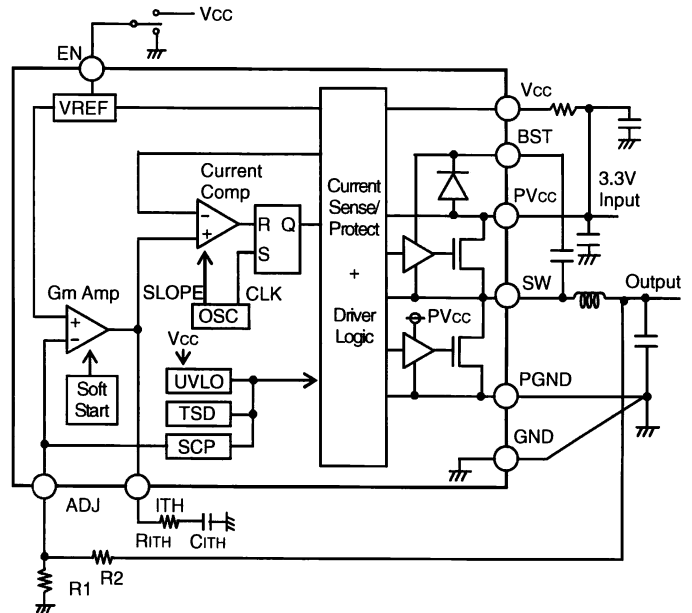

○ SETTING THE OUTPUT VOLTAGE

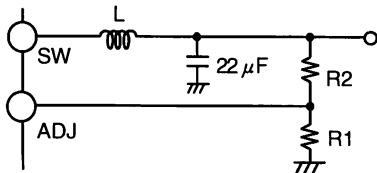

The Output Voltage is set by the external resistor divider and is calculated as :  
 $V_{out} = (R2/R1 + 1) \times V_{ADJ}$  . . . ①  $V_{ADJ}$  : ADJ pin reference Voltage (0.8V typ)  
 It's possible to adjust the output voltage by R1 and R2. (The  $V_{out}$  must be set from 0.8V to 2.5V.)  
 Resistance R1 ≅ 10kΩ is recommended. Please confirm the ripple voltage, if you can use the resistance more than 100kΩ.

○ PIN No., PIN NAME

PIN No.	PIN NAME	PIN No.	PIN NAME
1	SW	11	GND
2	SW	12	ADJ
3	SW	13	ITH
4	SW	14	N.C.
5	SW	15	N.C.
6	PVcc	16	N.C.
7	PVcc	17	EN
8	PVcc	18	PGND
9	BST	19	PGND
10	Vcc	20	PGND

## ○NOTES FOR USE

## (1) Absolute Maximum Ratings

We are careful enough for quality control about this IC. So, there is no problem under normal operation, excluding that it exceeds the absolute maximum ratings. However, this IC might be destroyed when the absolute maximum ratings, such as impressed voltages or the operating temperature range, is exceeded, and whether the destruction is short circuit mode or open circuit mode cannot be specified. Take into consideration the physical countermeasures for safety, such as fusing, if a particular mode that exceeds the absolute maximum rating is assumed.

## (2) GND Potential

Make setting of the potential of the GND terminal so that it will be maintained at the minimum in any operating state. Furthermore, check to be sure no terminals are at a potential lower than the GND voltage except for SW, PGND, GND terminals including an actual electric transient.

## (3) Thermal design

Do not exceed the power dissipation (Pd) of the package specification rating under actual operation, and design enough temperature margins.

## (4) Short circuit mode between terminals and wrong mounting

In order to mount the IC on a set PCB, pay thorough attention to the direction and offset of the ICs. Erroneous mounting can destroy the IC. Furthermore, if a short circuit occurs due to foreign matters entering between terminals or between the terminal and the power supply or the GND terminal, the IC can destroy

## (5) TSD(Thermal Shut-Down) circuit

The thermal shutdown circuit (TSD circuit) is built in this product. When IC chip temperature becomes higher, the thermal shutdown circuit operates and turns output off. The guarantee and protection of IC are not purpose. Therefore, do not use this IC after TSD circuit operates, nor use it for assumption that operates the TSD circuit.

## (6) GND wiring pattern

Use separate ground lines for control signals and high current power driver outputs. Because these high current outputs that flows to the wire impedance changes the GND voltage for control signal. Therefore, each ground terminal of IC must be connected at the one point on the set circuit board. As for GND of external parts, it is similar to the above-mentioned.

## (7) Operation in supply voltage range

Functional Circuit operation is guaranteed within operation ambient temperature, as long as it is within operation supply voltage range. The electrical characteristics standard value cannot be guaranteed. However, there is no drastic variation in these values, as long as it is within operation supply voltage range.

(8) We are confident in recommending the above application circuit example, but we ask that you carefully check the characteristics of this circuit before using it. If using this circuit after modifying other external circuit constants, be careful to ensure adequate margins for variation between external devices and this IC, including not only static characteristics but also transient characteristics. If switching noise is high, insert the Low pass filter between Vcc pin and PVcc pin, insert the schottky barrier diodes or snubber between SW pin and PGND pin.

## (9) Overcurrent protection circuit

The overcurrent protection circuit is built in the output. If the protection circuit operates more than for specific hours (when the load is short.), the output will be latched in OFF. The output returns when EN is turned on or UVLO is released again. These protection circuits are effective in the destruction prevention by broken accident. Do not design for continuously this protection circuit working.

## (10) Selection of inductor

It is recommended to use an inductor with a series resistance element (DCR) 0.1  $\Omega$  or less. Especially, in case output voltage is set 1.6V or more, note that use of a high DCR inductor will cause an inductor loss, resulting in decreased output voltage. Should this condition continue for a specified period (soft start time + timer latch time), output short circuit protection will be activated and output will be latched OFF. When using an inductor over 0.1  $\Omega$ , be careful to ensure adequate margins for variation between external devices and this IC, including transient as well as static characteristics.

### Notes

- No technical content pages of this document may be reproduced in any form or transmitted by any means without prior permission of ROHM CO.,LTD.
- The contents described herein are subject to change without notice. The specifications for the product described in this document are for reference only. Upon actual use, therefore, please request that specifications to be separately delivered.
- Application circuit diagrams and circuit constants contained herein are shown as examples of standard use and operation. Please pay careful attention to the peripheral conditions when designing circuits and deciding upon circuit constants in the set.
- Any data, including, but not limited to application circuit diagrams information, described herein are intended only as illustrations of such devices and not as the specifications for such devices. ROHM CO.,LTD. disclaims any warranty that any use of such devices shall be free from infringement of any third party's intellectual property rights or other proprietary rights, and further, assumes no liability of whatsoever nature in the event of any such infringement, or arising from or connected with or related to the use of such devices.
- Upon the sale of any such devices, other than for buyer's right to use such devices itself, resell or otherwise dispose of the same, no express or implied right or license to practice or commercially exploit any intellectual property rights or other proprietary rights owned or controlled by
- ROHM CO., LTD. is granted to any such buyer.
- Products listed in this document are no antiradiation design.

The products listed in this document are designed to be used with ordinary electronic equipment or devices (such as audio visual equipment, office-automation equipment, communications devices, electrical appliances and electronic toys).

Should you intend to use these products with equipment or devices which require an extremely high level of reliability and the malfunction of which would directly endanger human life (such as medical instruments, transportation equipment, aerospace machinery, nuclear-reactor controllers, fuel controllers and other safety devices), please be sure to consult with our sales representative in advance.

It is our top priority to supply products with the utmost quality and reliability. However, there is always a chance of failure due to unexpected factors. Therefore, please take into account the derating characteristics and allow for sufficient safety features, such as extra margin, anti-flammability, and fail-safe measures when designing in order to prevent possible accidents that may result in bodily harm or fire caused by component failure. ROHM cannot be held responsible for any damages arising from the use of the products under conditions out of the range of the specifications or due to non-compliance with the NOTES specified in this catalog.

Thank you for your accessing to ROHM product informations.

More detail product informations and catalogs are available, please contact your nearest sales office.

**ROHM** Customer Support System

THE AMERICAS / EUROPE / ASIA / JAPAN

[www.rohm.com](http://www.rohm.com)

Contact us : [webmaster@rohm.co.jp](mailto:webmaster@rohm.co.jp)