

**3 Watt Zener Diode • 5% Tolerance • Case C**

CENTRAL TYPE NO.	Zener Voltage Vz @ Iz	Test Current Iz	Zener Impedance Zz	Maximum Zener Current IzM	CENTRAL TYPE NO.	Zener Voltage Vz @ Iz	Test Current Iz	Zener Impedance Zz	Maximum Zener Current IzM
	Volts	mA	Ohms	mA		Volts	mA	Ohms	mA
C3Z6.2B	6.2	75	2.0	480	C3Z47B	47	15	43	64
C3Z6.8B	6.8	75	2.0	440	C3Z50B	50	15	50	60
C3Z7.5B	7.5	75	2.0	400	C3Z51B	51	15	50	59
C3Z8.2B	8.2	75	3.0	366	C3Z52B	52	15	60	58
C3Z9.1B	9.1	75	3.0	330	C3Z56B	56	10	70	64
C3Z10B	10	75	4.0	300	C3Z62B	62	10	75	48
C3Z11B	11	70	5.0	273	C3Z68B	68	10	85	44
C3Z12B	12	60	5.0	250	C3Z75B	75	10	100	40
C3Z13B	13	50	6.0	231	C3Z82B	82	10	120	37
C3Z14B	14	50	6.0	214	C3Z91B	91	8.0	155	33
C3Z15B	15	50	6.0	200	C3Z100B	100	7.0	175	30
C3Z16B	16	50	7.0	188	C3Z105B	105	6.0	200	29
C3Z17B	17	50	7.0	176	C3Z110B	110	5.0	250	27
C3Z18B	18	40	8.0	167	C3Z120B	120	5.0	325	25
C3Z19B	19	40	9.0	158	C3Z130B	130	5.0	375	23
C3Z20B	20	40	9.0	150	C3Z140B	140	5.0	550	21
C3Z22B	22	30	10	136	C3Z150B	150	5.0	625	20
C3Z24B	24	30	10	125	C3Z160B	160	4.0	700	19
C3Z25B	25	30	10	120	C3Z180B	180	4.0	850	17
C3Z27B	27	25	12	111	C3Z200B	200	4.0	950	15
C3Z30B	30	25	15	100					
C3Z33B	33	20	21	91					
C3Z36B	36	20	21	83					
C3Z39B	39	20	27	77					
C3Z43B	43	15	35	70					
C3Z45B	45	15	37	67					

**5 Watt Zener Diode • 5% Tolerance • Case C**

TYPE NO.	CENTRAL TYPE NO.	Zener Voltage Vz @ Iz	Test Current Iz	Zener Impedance Zz	Maximum Zener Current IzM	TYPE NO.	CENTRAL TYPE NO.	Zener Voltage Vz @ Iz	Test Current Iz	Zener Impedance Zz	Maximum Zener Current IzM
		Volts	mA	Ohms	mA			Volts	mA	Ohms	mA
1N5333B	C5Z3.3B	3.3	380	3.0	1440	1N5361B	C5Z27B	27	50	5.0	176
1N5334B	C5Z3.6B	3.6	350	2.5	1320	1N5362B	C5Z28B	28	50	6.0	170
1N5335B	C5Z3.9B	3.9	320	2.0	1220	1N5363B	C5Z30B	30	40	8.0	158
1N5336B	C5Z4.3B	4.3	290	2.0	1100	1N5364B	C5Z33B	33	40	10	144
1N5337B	C5Z4.7B	4.7	260	2.0	1010	1N5365B	C5Z36B	36	30	11	132
1N5338B	C5Z5.1B	5.1	240	1.5	930	1N5366B	C5Z39B	39	30	14	122
1N5339B	C5Z5.6B	5.6	220	1.0	865	1N5367B	C5Z43B	43	30	20	110
1N5340B	C5Z6.0B	6.0	200	1.0	790	1N5368B	C5Z47B	47	25	25	100
1N5341B	C5Z6.2B	6.2	200	1.0	765	1N5369B	C5Z51B	51	25	27	93.0
1N5342B	C5Z6.8B	6.8	175	1.0	700	1N5370B	C5Z56B	56	20	35	86.0
1N5343B	C5Z7.5B	7.5	175	1.5	630	1N5371B	C5Z60B	60	20	40	79.0
1N5344B	C5Z8.2B	8.2	150	1.5	580	1N5372B	C5Z62B	62	20	42	76.0
1N5345B	C5Z8.7B	8.7	150	2.0	545	1N5373B	C5Z68B	68	20	44	70.0
1N5346B	C5Z9.1B	9.1	150	2.0	520	1N5374B	C5Z75B	75	20	45	63.0
1N5347B	C5Z10B	10	125	2.0	475	1N5375B	C5Z82B	82	15	65	58.0
1N5348B	C5Z11B	11	125	2.5	430	1N5376B	C5Z87B	87	15	75	54.0
1N5349B	C5Z12B	12	100	2.5	395	1N5377B	C5Z91B	91	15	75	52.5
1N5350B	C5Z13B	13	100	2.5	365	1N5378B	C5Z100B	100	12	90	47.5
1N5351B	C5Z14B	14	100	2.5	340	1N5379B	C5Z110B	110	12	125	43.0
1N5352B	C5Z15B	15	75	2.5	315	1N5380B	C5Z120B	120	10	170	39.5
1N5353B	C5Z16B	16	75	2.5	295	1N5381B	C5Z130B	130	10	190	36.6
1N5354B	C5Z17B	17	70	2.5	280	1N5382B	C5Z140B	140	8.0	230	34.0
1N5355B	C5Z18B	18	65	2.5	264	1N5383B	C5Z150B	150	8.0	330	31.6
1N5356B	C5Z19B	19	65	3.0	250	1N5384B	C5Z160B	160	8.0	350	29.4
1N5357B	C5Z20B	20	65	3.0	237	1N5385B	C5Z170B	170	8.0	380	28.0
1N5358B	C5Z22B	22	50	3.5	216	1N5386B	C5Z180B	180	5.0	430	26.4
1N5359B	C5Z24B	24	50	3.5	198	1N5387B	C5Z190B	190	5.0	450	25.0
1N5360B	C5Z25B	25	50	4.0	190	1N5388B	C5Z200B	200	5.0	480	23.6

# CASE OUTLINE DRAWINGS

D

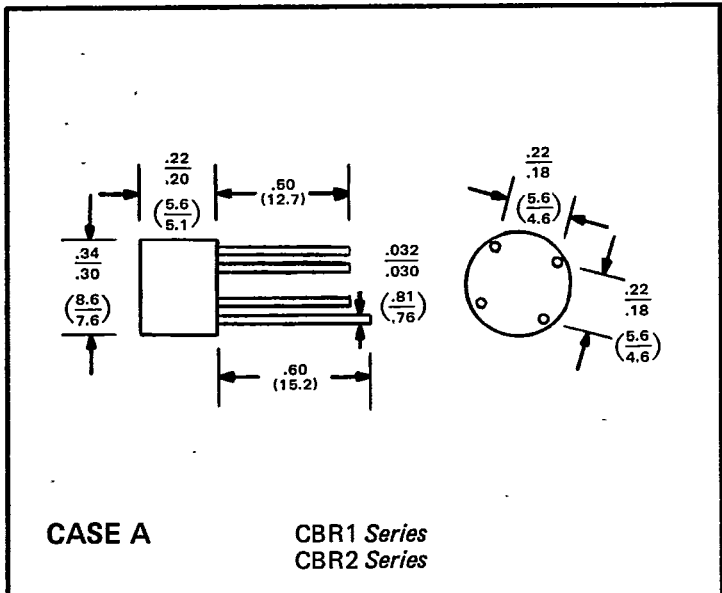

CASE A

CBR1 Series  
CBR2 Series

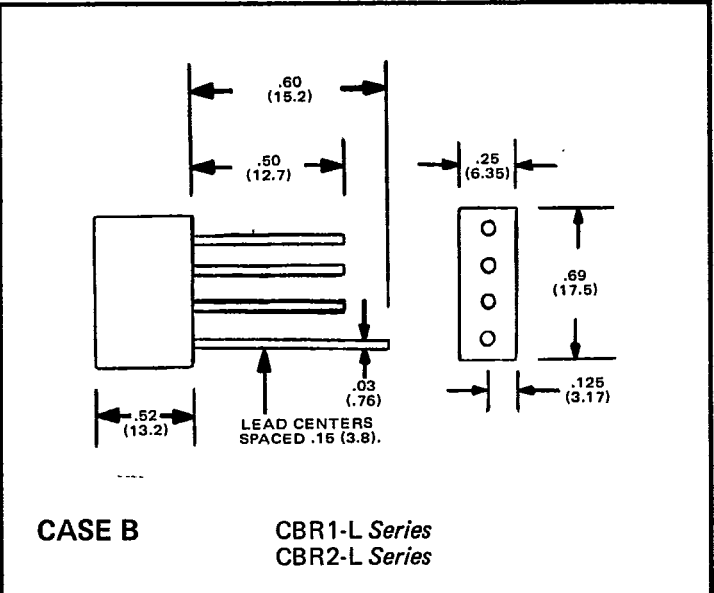

CASE B

CBR1-L Series  
CBR2-L Series

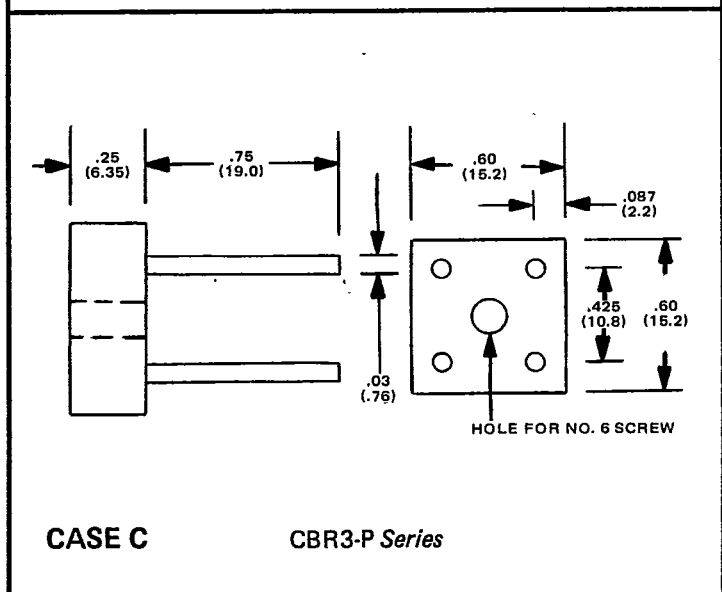

CASE C

CBR3-P Series

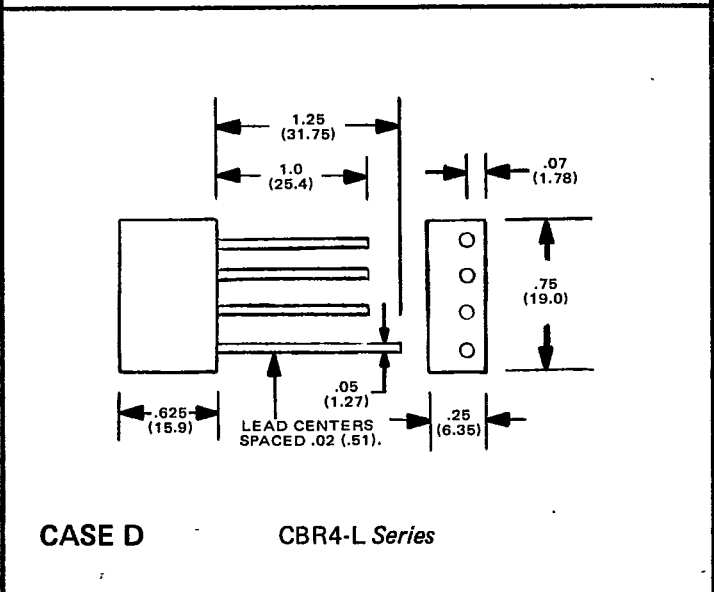

CASE D

CBR4-L Series

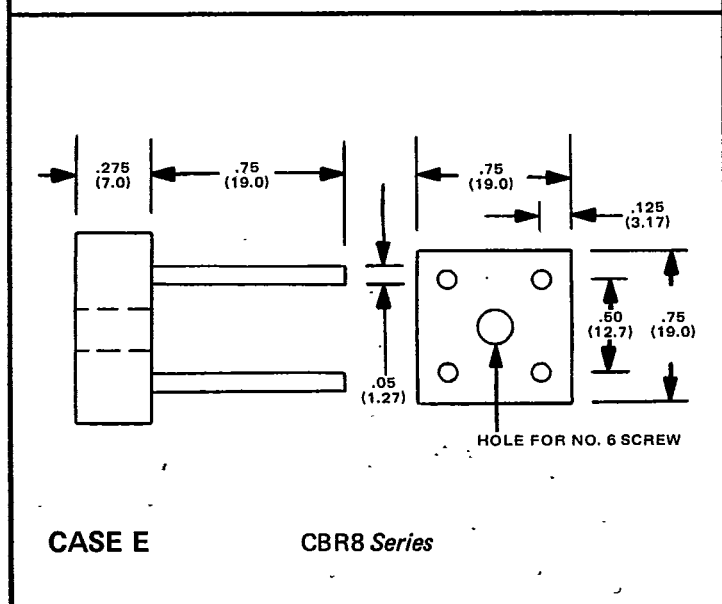

CASE E

CBR8 Series

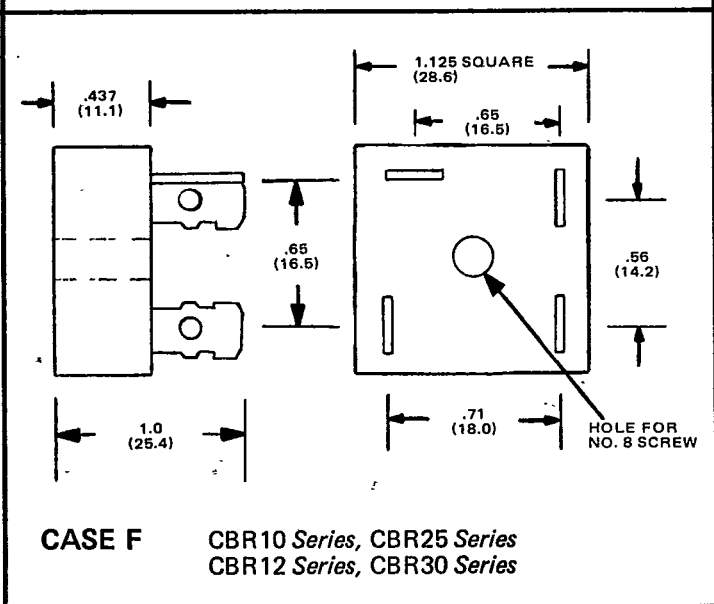

CASE F

CBR10 Series, CBR25 Series  
CBR12 Series, CBR30 Series

All Dimensions in Inches (Millimeters)  
Drawings Not To Scale

f

# MECHANICAL OUTLINE DRAWINGS

TO-5

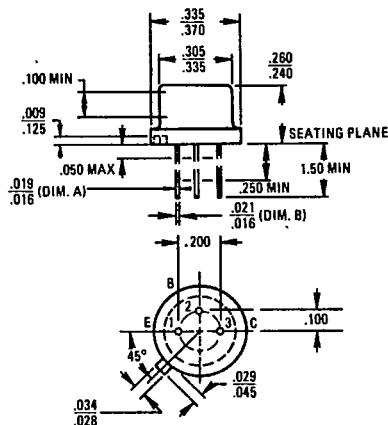

TO-18

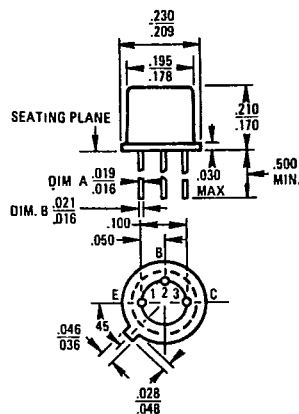

TO-39

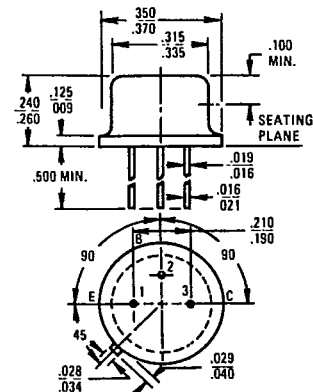

TO-46

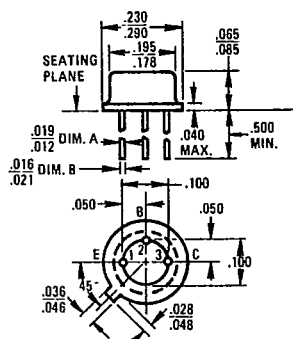

TO-72

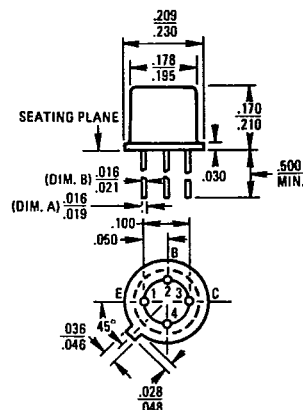

TO-92

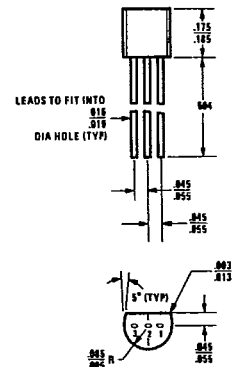

TO-98

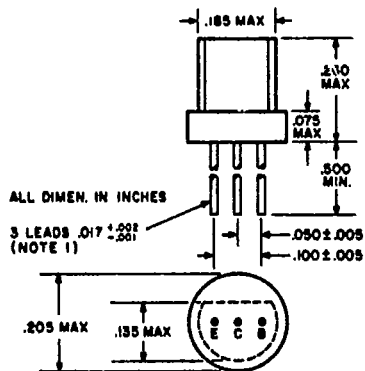

TO-105

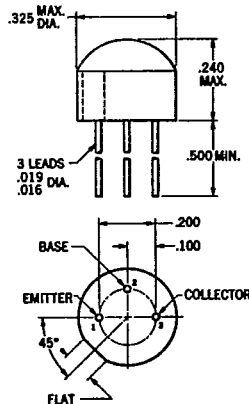

TO-106

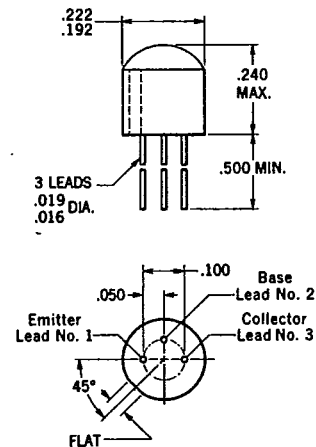

# OUTLINE DRAWINGS FOR CENTRAL SEMICONDUCTOR ZENER DIODES

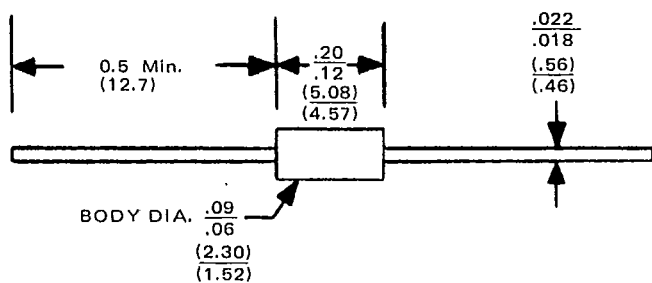

CASE A (Do-35)

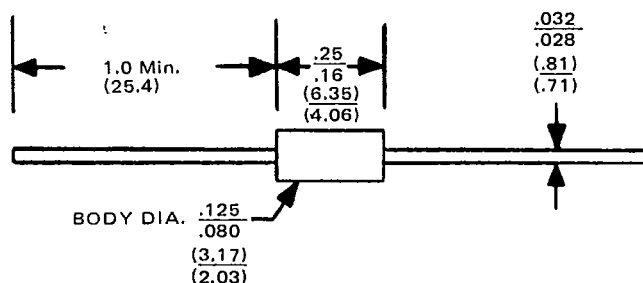

CASE B

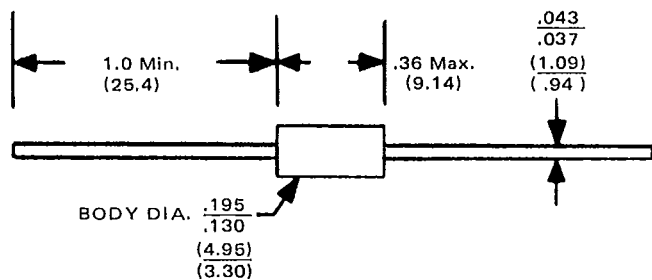

CASE C

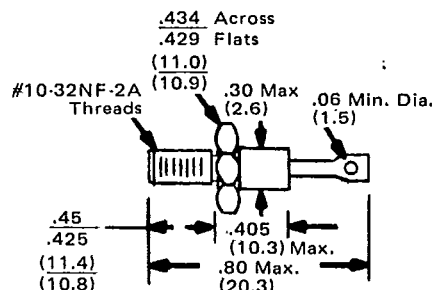

CASE D (Do-4)

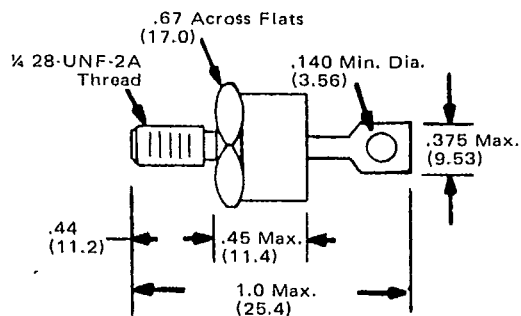

CASE E (Do-5)

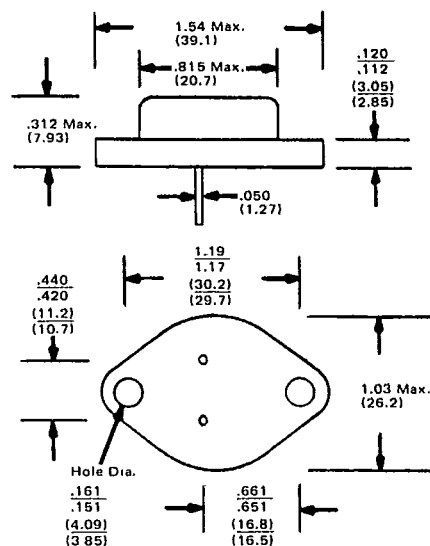

CASE F (To-3)

ALL DIMENSIONS IN INCHES (MILLIMETERS)

DRAWINGS NOT TO SCALE