

0.5 mm PITCH STACKING CONNECTORS (2.5 mm STACKING HEIGHT)

FCN-290 SERIES

■ FEATURES

- Terminal pitch of 0.5 mm (0.020 in.), SMT terminals (for both plug and socket).
- This connector can connect boards in parallel with 2.5mm (0.098 in.) stacking height .
- Bellows contacts provide reliable interconnection.
- Product is packaged in embossed carrier tape and reel. Two package sizes are available.
 - 3000 pcs per reel
 - 500 pcs per reel

■ SPECIFICATIONS

Item	Specification
Operating temperature range	-40° to +85 ° C
Rated current	0.3A DC
Rated voltage	200V AC 300V DC
Contact resistance	40mΩ max
Insulation resistance	500V DC, 100MΩ min.
Dielectric withstand voltage	500V AC, 1 min.

■ MATERIALS

Item	Material
Insulator	LCP
Conductor	Copper alloy
Plating	Surface finish of contact: PAGOS® Terminal: Palladium

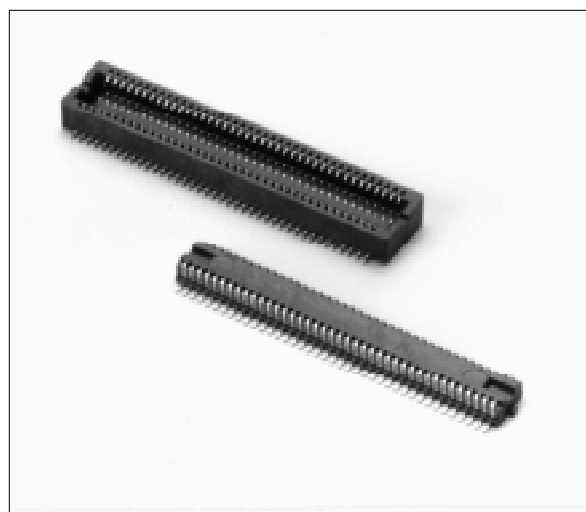

290 Series (0.5mm Pitch Stacking Height)

SOCKET, SMT

■ DIMENSIONS

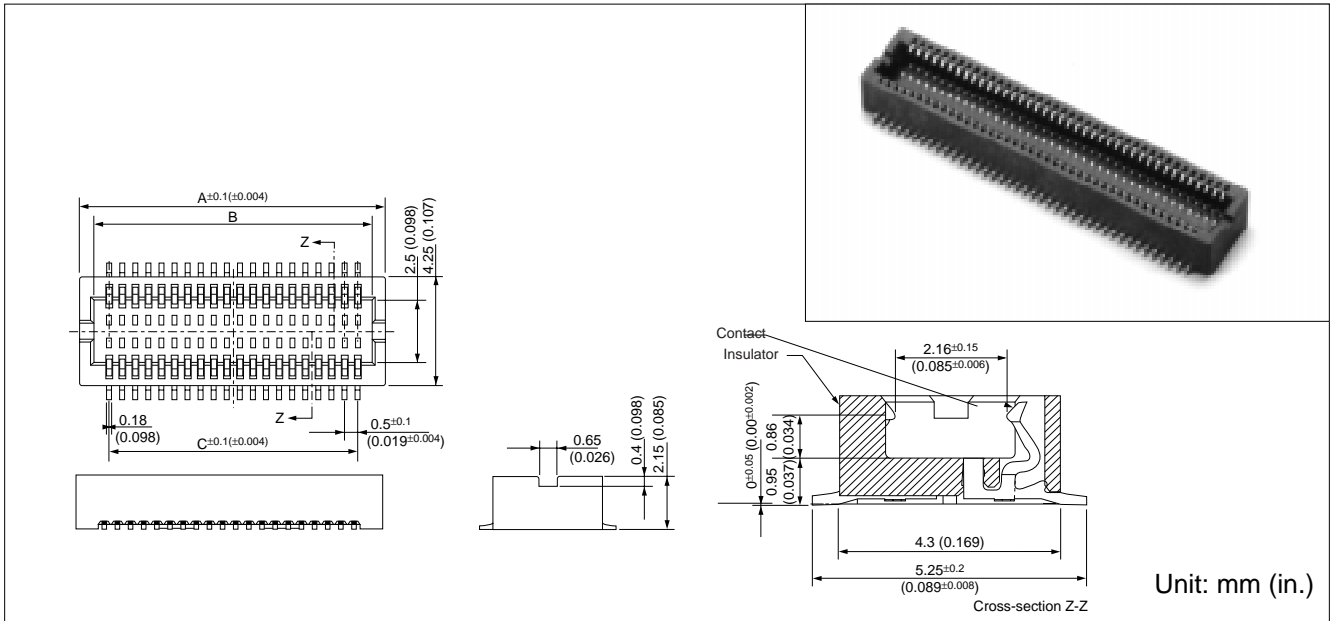

■ RECOMMENDED PC BOARD MOUNTING PATTERN (MOUNTING SIDE)

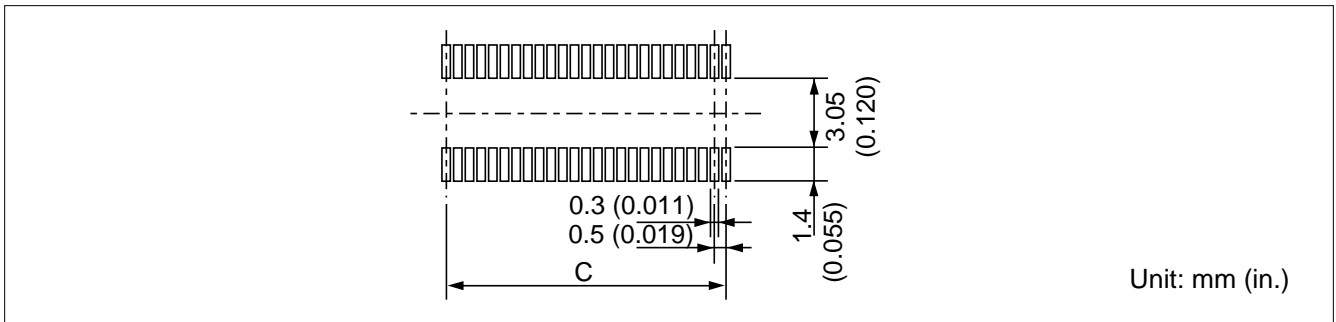

■ ORDERING PART NUMBER AND DIMENSIONS

Number of Contacts	Part Number	Dimensions: mm (in.)			Units of Order
		A	B	C	
30	FCN-298B030-L/0	9.25 (0.364)	8.05 (0.317)	7.0 (0.276)	3000 units
40	FCN-298B040-L/0	11.75 (0.463)	10.55 (0.415)	9.5 (0.374)	
50	FCN-298B050-L/0	14.25 (0.461)	13.05 (0.514)	12.0 (0.472)	
60	FCN-298B060-L/0	16.75 (0.659)	15.55 (0.612)	14.5 (0.570)	
70	FCN-298B070-L/0	19.25 (0.758)	18.04 (0.710)	17.0 (0.660)	
80	FCN-298B080-L/0	21.75 (0.856)	20.55 (0.809)	19.5 (0.768)	
90	FCN-298B090-L/0	24.25 (0.955)	23.04 (0.907)	22.0 (0.866)	
100	FCN-298B100-L/0	26.75 (1.053)	25.55(1.006)	24.5 (0.965)	
120	FCN-298B120-L/0	31.75 (1.250)	30.55(1.203)	29.5(1.161)	

Connectors are shipped packaged in emboss carrier tape (3000 units/reel). To order reel with 500pcs/reel, add "-1" to part number

290 Series (0.5mm Pitch Stacking Height)

PLUG, SMT

■ DIMENSIONS

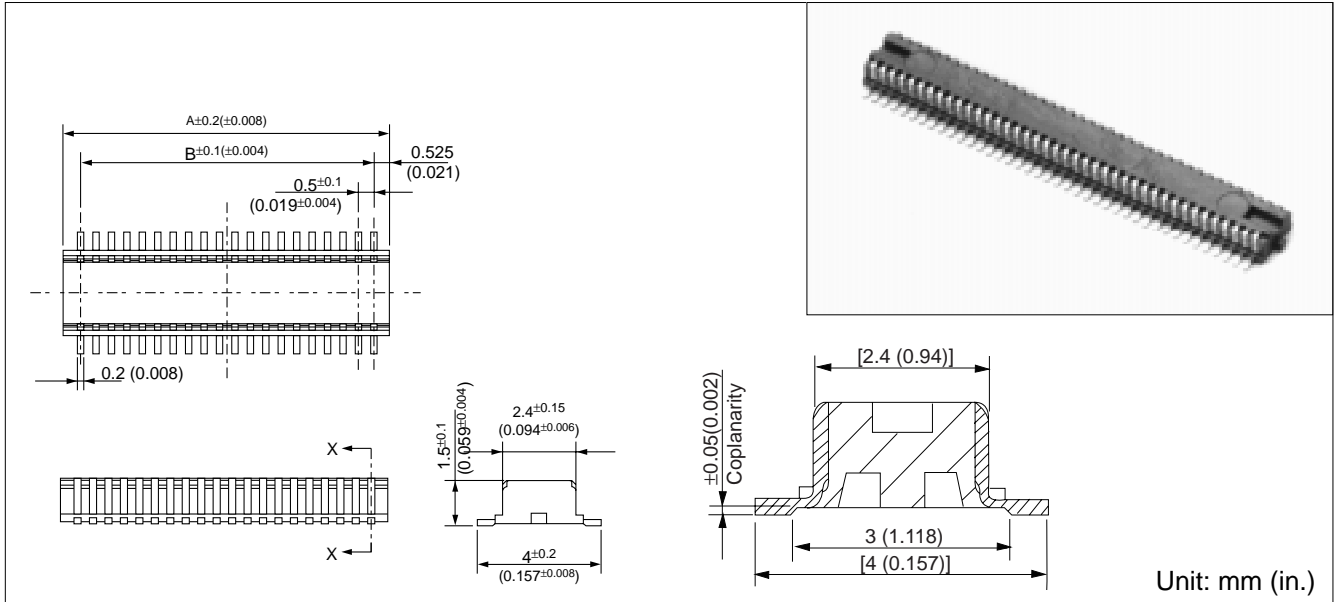

■ RECOMMENDED PC BOARD MOUNTING PATTERN (MOUNTING SIDE)

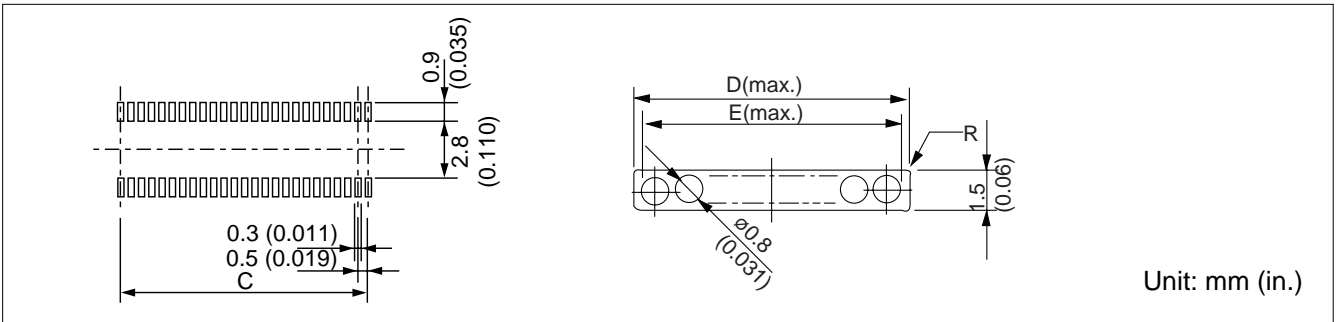

■ ORDERING PART NUMBER AND DIMENSIONS

Number of Contacts	Part Number	Dimensions: mm (in.)		Units of Order
		A	B	
30	FCN-298Q030-L/0	8.0 (0.314)	7.0 (0.276)	3000 units
40	FCN-298Q040-L/0	10.5 (0.413)	9.5 (0.374)	
50	FCN-298Q050-L/0	13.0 (0.512)	12.0 (0.472)	
60	FCN-298Q060-L/0	15.5 (0.610)	14.5 (0.570)	
70	FCN-298Q070-L/0	17.97 (0.707)	17.0 (0.660)	
80	FCN-298Q080-L/0	20.5 (0.807)	19.5 (0.768)	
90	FCN-298Q090-L/0	22.97 (0.904)	22.0 (0.866)	
100	FCN-298Q100-L/0	25.5 (1.004)	24.5 (0.965)	
120	FCN-298Q120-L/0	30.5 (1.201)	29.5 (1.161)	

Connectors are shipped packaged in emboss carrier tape (3000 units/reel). To order reel with 500pcs/reel, add "-1" to part number.

290 Series (0.5mm Pitch Stacking Height)

Fujitsu Components International Headquarter Offices

Japan

Fujitsu Component Limited
Gotanda-Chuo Building
3-5, Higashigotanda 2-chome, Shinagawa-ku
Tokyo 141, Japan
Tel: (81-3) 5449-7010
Fax: (81-3) 5449-2626
Email: promothq@ft.ed.fujitsu.com
Web: www.fcl.fujitsu.com

North and South America

Fujitsu Components America, Inc.
250 E. Caribbean Drive
Sunnyvale, CA 94089 U.S.A.
Tel: (1-408) 745-4900
Fax: (1-408) 745-4970
Email: marcom@fcai.fujitsu.com
Web: www.fcai.fujitsu.com

Europe

Fujitsu Components Europe B.V.
Diamantlaan 25
2132 WV Hoofddorp
Netherlands
Tel: (31-23) 5560910
Fax: (31-23) 5560950
Email: info.marketing@fceu.fujitsu.com
Web: www.fceu.fujitsu.com

Asia Pacific

Fujitsu Components Asia Ltd.
102E Pasir Panjang Road
#04-01 Citilink Warehouse Complex
Singapore 118529
Tel: (65) 375-8560
Fax: (65) 273-3021
Email: fcal@fcal.fujitsu.com
www.fcal.fujitsu.com

© 2001 Fujitsu Components America, Inc. All company and product names are trademarks or registered trademarks of their respective owners. Rev. 09/2001