



SGS-THOMSON
MICROELECTRONICS

TIP140T/141T/142T
TIP145T/146T/147T

S G S-THOMSON

3DE D

LOW VOLTAGE HIGH CURRENT POWER DARLINGTON

ADVANCE DATA

- MONOLITHIC DARLINGTON CONFIGURATION
- LOW VOLTAGE
- HIGH CURRENT
- HIGH GAIN

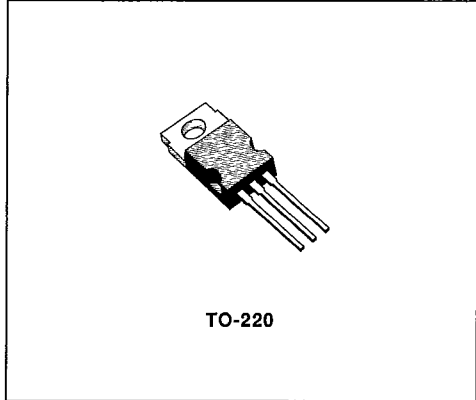

DESCRIPTION

The TIP140T, TIP141T and TIP142T are silicon multiepitaxial base NPN transistor in monolithic Darlington configuration mounted in TO-220 package.

They are intended for use in power linear and switching applications. The complementary PNP types are the TIP145T, TIP146T and TIP147T respectively.

INTERNAL SCHEMATIC DIAGRAM

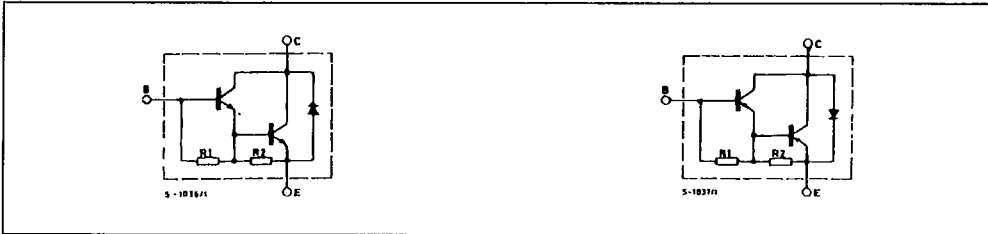

ABSOLUTE MAXIMUM RATINGS

Symbol	Parameter	NPN PNP	Value			Unit
			TIP140T TIP145T	TIP141T TIP146T	TIP142T TIP147T	
V_{CBO}	Collector-base Voltage ($I_E = 0$)		60	80	100	V
V_{CEO}	Collector-emitter Voltage ($I_B = 0$)		60	80	100	V
V_{EBO}	Emitter-base Voltage ($I_C = 0$)		5			V
I_C	Collector Current		15			A
I_{CM}	Collector Peak Current ($t_p < 5ms$)		20			A
I_B	Base Current		0.5			A
P_{tot}	Total Dissipation at $T_o < 25^\circ C$		125			W
T_{stg}	Storage Temperature		- 65 to 150			$^\circ C$
T_j	Max. Operating Junction Temperature		150			$^\circ C$

For PNP types voltage and current values are negative.

February 1989

1/2

This is advanced information on a new product now in development or undergoing evaluation. Details are subject to change without notice.

THERMAL DATA

SGS-THOMSON

30E D

$R_{thj-case}$	Thermal Resistance Junction-case	max	1	°C/W
----------------	----------------------------------	-----	---	------

T-33-29

ELECTRICAL CHARACTERISTICS ($T_{case} = 25^{\circ}C$ unless otherwise specified)

Symbol	Parameter	Test Conditions	Min.	Typ.	Max.	Unit
I_{CBO}	Collector Cutoff Current ($I_E = 0$)	$V_{CB} = 60V$ for TIP140T/145T $V_{CB} = 80V$ for TIP141T/146T $V_{CB} = 100V$ for TIP142T/147T			1 1 1	mA mA mA
I_{CEO}	Collector Cutoff Current ($I_B = 0$)	$V_{CE} = 30V$ for TIP140T/145T $V_{CE} = 40V$ for TIP141T/146T $V_{CE} = 50V$ for TIP142T/147T			2 2 2	mA mA mA
I_{EB0}	Emitter Cutoff Current ($I_C = 0$)	$V_{EB} = 5V$			2	mA
$V_{CEO(sus)}^*$	Collector-emitter Sustaining Voltage	$I_C = 30mA$ for TIP140T/145T for TIP141T/146T for TIP142T/147T	60 80 100			V V V
$V_{CE(sat)}^*$	Collector-emitter Saturation Voltage	$I_C = 5A$ $I_B = 10mA$ $I_C = 10A$ $I_B = 40mA$			2 3	V V
$V_{BE(on)}^*$	Base-emitter Voltage	$I_C = 10A$ $V_{CE} = 4V$			3	V
h_{FE}^*	DC Current Gain	$I_C = 5A$ $V_{CE} = 4V$ $I_C = 10A$ $V_{CE} = 4V$	1000 500			
t_{on} t_{off}	RESISTIVE LOAD Turn-on Time Turn-off Time	$I_C = 10A$ $I_{B1} = 10mA$ $I_{B2} = -40mA$ $R_L = 3\Omega$		0.9 4		μs μs

* Pulsed : pulse duration = 300 μs , duty cycle = 1.5%.
For PNP types voltage and current value are negative.