

TOSHIBA CMOS Digital Integrated Circuit Silicon Monolithic

TC74ACT245P, TC74ACT245F, TC74ACT245FW, TC74ACT245FT TC74ACT640P, TC74ACT640F, TC74ACT640FW, TC74ACT640FT

Octal Bus Transceiver

TC74ACT245P/F/FW/FT 3-State,
Non-Inverting

TC74ACT640P/F/FW/FT 3-State, Inverting

Note: xxxFW (JEDEC SOP) is not available in Japan.

The TC74ACT245 and 640 are advanced high speed CMOS OCTAL BUS TRANSCEIVERS fabricated with silicon gate and double-layer metal wiring C²MOS technology.

They achieve the high speed operation similar to equivalent Bipolar Schottky TTL while maintaining the CMOS low power dissipation.

These devices may be used as a level converter for interfacing TTL or NMOS to High Speed CMOS. The inputs are compatible with TTL, NMOS and CMOS output voltage levels.

They are intended for two-way asynchronous communication between data busses. The direction of data transmission is determined by the level of the DIR input.

The enable input (\bar{G}) can be used to disable the device so that the busses are effectively isolated.

All inputs are equipped with protection circuits against static discharge or transient excess voltage.

Features (Note 1) (Note 2)

- High speed: $t_{pd} = 4.7$ ns (typ.) at $V_{CC} = 5$ V
- Low power dissipation: $I_{CC} = 8$ μ A (max) at $T_a = 25^\circ$ C
- Compatible with TTL outputs
: $V_{IL} = 0.8$ V (max), $V_{IH} = 2.0$ V (min)
- Symmetrical output impedance
: $|I_{OH}| = I_{OL} = 24$ mA (min)
Capability of driving 50 Ω transmission lines.
- Balanced propagation delays: $t_{pLH} \approx t_{pHL}$
- Pin and function compatible with 74F245/640

Note 1: Do not apply a signal to any bus terminal when it is in the output mode. Damage may result.

Note 2: All floating (high impedance) bus terminals must have their input levels fixed by means of pull up or pull down resistors.

Weight	
DIP20-P-300-2.54A	: 1.30 g (typ.)
SOP20-P-300-1.27A	: 0.22 g (typ.)
SOP20-P-300-1.27	: 0.22 g (typ.)
SOL20-P-300-1.27	: 0.46 g (typ.)
TSSOP20-P-0044-0.65A	: 0.08 g (typ.)

TC74ACT245P, TC74ACT640P

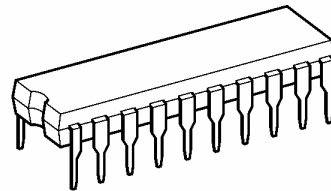

DIP20-P-300-2.54A

TC74ACT245F, TC74ACT640F

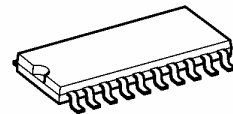

SOP20-P-300-1.27A

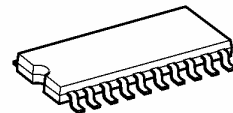

SOP20-P-300-1.27

TC74ACT245FW, TC74ACT640FW

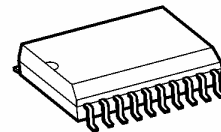

SOL20-P-300-1.27

TC74ACT245FT, TC74ACT640FT

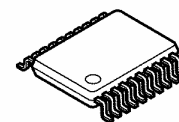

TSSOP20-P-0044-0.65A

Pin Assignment

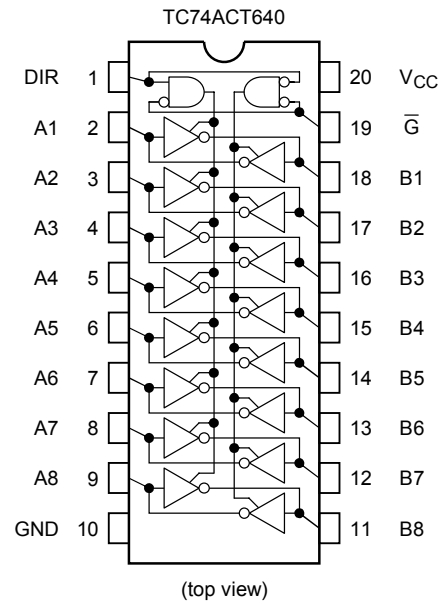
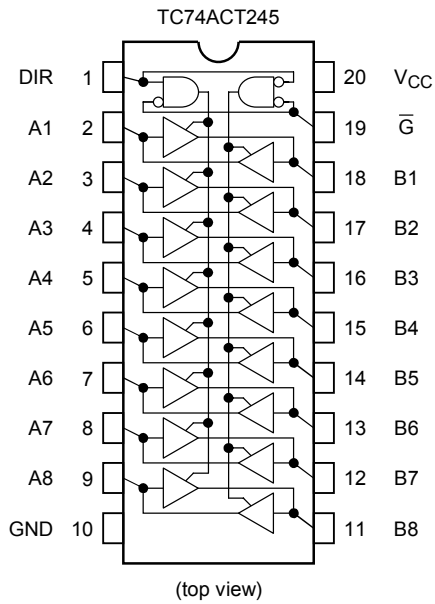

IEC Logic Symbol

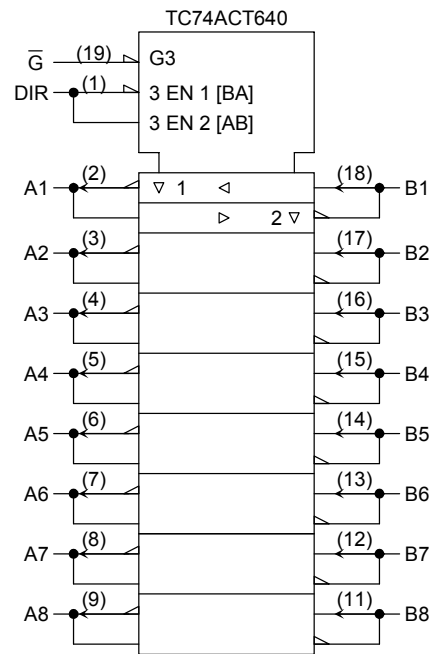
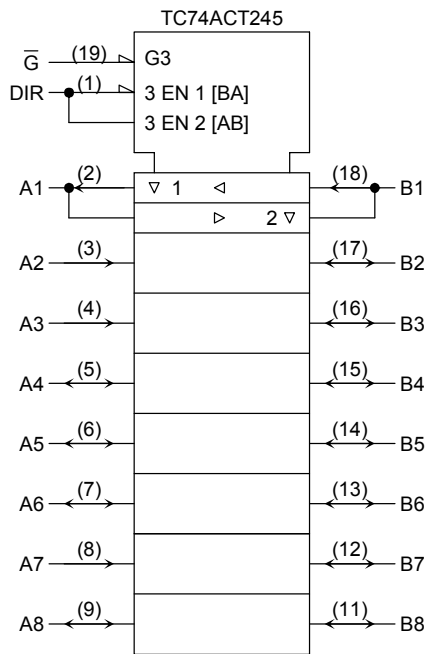

Truth Table

Inputs		Function		Outputs	
\bar{G}	DIR	A Bus	B Bus	ACT245	ACT640
L	L	Output	Input	A = B	A = \bar{B}
L	H	Input	Output	B = A	B = \bar{A}
H	X	Z		Z	Z

X: Don't care

Z: High impedance

Absolute Maximum Ratings (Note 1)

Characteristics	Symbol	Rating	Unit
Supply voltage range	V_{CC}	-0.5 to 7.0	V
DC input voltage	V_{IN}	-0.5 to $V_{CC} + 0.5$	V
DC output voltage	V_{OUT}	-0.5 to $V_{CC} + 0.5$	V
Input diode current	I_{IK}	± 20	mA
Output diode current	I_{OK}	± 50	mA
DC output current	I_{OUT}	± 50	mA
DC V_{CC} /ground current	I_{CC}	± 200	mA
Power dissipation	P_D	500 (DIP) (Note 2)/180 (SOP/TSSOP)	mW
Storage temperature	T_{stg}	-65 to 150	$^{\circ}C$

Note 1: Exceeding any of the absolute maximum ratings, even briefly, lead to deterioration in IC performance or even destruction.

Note 2: 500 mW in the range of $T_a = -40^{\circ}C$ to $65^{\circ}C$. From $T_a = 65^{\circ}C$ to $85^{\circ}C$ a derating factor of -10 mW/ $^{\circ}C$ should be applied up to 300 mW.

Operating Range (Note)

Characteristics	Symbol	Rating	Unit
Supply voltage	V_{CC}	4.5 to 5.5	V
Input voltage	V_{IN}	0 to V_{CC}	V
Output voltage	V_{OUT}	0 to V_{CC}	V
Operating temperature	T_{opr}	-40 to 85	$^{\circ}C$
Input rise and fall time	dt/dV	0 to 10	ns/V

Note: The operating range is required to ensure the normal operation of the device. Unused inputs and bus inputs must be tied to either V_{CC} or GND. Please connect both bus inputs and the bus outputs with V_{CC} or GND when the I/O of the bus terminal changes by the function. In this case, please note that the output is not short-circuited.

Electrical Characteristics

DC Characteristics

Characteristics	Symbol	Test Condition		V _{CC} (V)	Ta = 25°C			Ta = -40 to 85°C		Unit
					Min	Typ.	Max	Min	Max	
High-level input voltage	V _{IH}	—		4.5 to 5.5	2.0	—	—	2.0	—	V
Low-level input voltage	V _{IL}	—		4.5 to 5.5	—	—	0.8	—	0.8	V
High-level output voltage	V _{OH}	V _{IN} = V _{IH} or V _{IL}	I _{OH} = -50 μA	4.5	4.4	4.5	—	4.4	—	V
			I _{OH} = -24 mA	4.5	3.94	—	—	3.80	—	
			I _{OH} = -75 mA (Note)	5.5	—	—	—	3.85	—	
Low-level output voltage	V _{OL}	V _{IN} = V _{IH} or V _{IL}	I _{OL} = 50 μA	4.5	—	0.0	0.1	—	0.1	V
			I _{OL} = 24 mA	4.5	—	—	0.36	—	0.44	
			I _{OL} = 75 mA (Note)	5.5	—	—	—	—	1.65	
3-state output off-state current	I _{OZ}	V _{IN} = V _{IH} or V _{IL} V _{OUT} = V _{CC} or GND		5.5	—	—	±0.5	—	±5.0	μA
Input leakage current	I _{IN}	V _{IN} = V _{CC} or GND		5.5	—	—	±0.1	—	±1.0	μA
Quiescent supply current	I _{CC}	V _{IN} = V _{CC} or GND		5.5	—	—	8.0	—	80.0	μA
	I _C	Per input: V _{IN} = 3.4 V Other input: V _{CC} or GND		5.5	—	—	1.35	—	1.5	mA

Note: This spec indicates the capability of driving 50 Ω transmission lines.

One output should be tested at a time for a 10 ms maximum duration.

AC Characteristics ($C_L = 50 \text{ pF}$, $R_L = 500 \Omega$, input: $t_r = t_f = 3 \text{ ns}$)

Characteristics	Symbol	Test Condition	Ta = 25°C			Ta = -40 to 85°C		Unit	
			V _{CC} (V)	Min	Typ.	Max	Min		Max
Propagation delay time (Note 2)	t _{pLH}	—	5.0 ± 0.5	—	5.0	8.0	1.0	9.0	ns
	t _{pHL}								
Propagation delay time (Note 3)	t _{pLH}	—	5.0 ± 0.5	—	5.7	8.5	1.0	9.5	ns
	t _{pHL}								
Output enable time	t _{pZL}	—	5.0 ± 0.5	—	7.3	12.3	1.0	14.0	ns
	t _{pZH}								
Output disable time	t _{pLZ}	—	5.0 ± 0.5	—	6.3	9.7	1.0	11.0	ns
	t _{pHZ}								
Input capacitance	C _{IN}	DIR, \bar{G}	—	5	10	—	10	pF	
Bus input capacitance	C _{I/O}	A _n , B _n	—	13	—	—	—	pF	
Power dissipation capacitance (Note 1)	C _{PD}	TC74ACT245	—	38	—	—	—	pF	
		TC74ACT640	—	43	—	—	—		

Note 1: C_{PD} is defined as the value of the internal equivalent capacitance which is calculated from the operating current consumption without load.

Average operating current can be obtained by the equation:

$$I_{CC(\text{opr})} = C_{PD} \cdot V_{CC} \cdot f_{IN} + I_{CC}/8 \text{ (per bit)}$$

Note 2: For TC74ACT245 only

Note 3: For TC74ACT640 only

Package Dimensions

DIP20-P-300-2.54A

Unit : mm

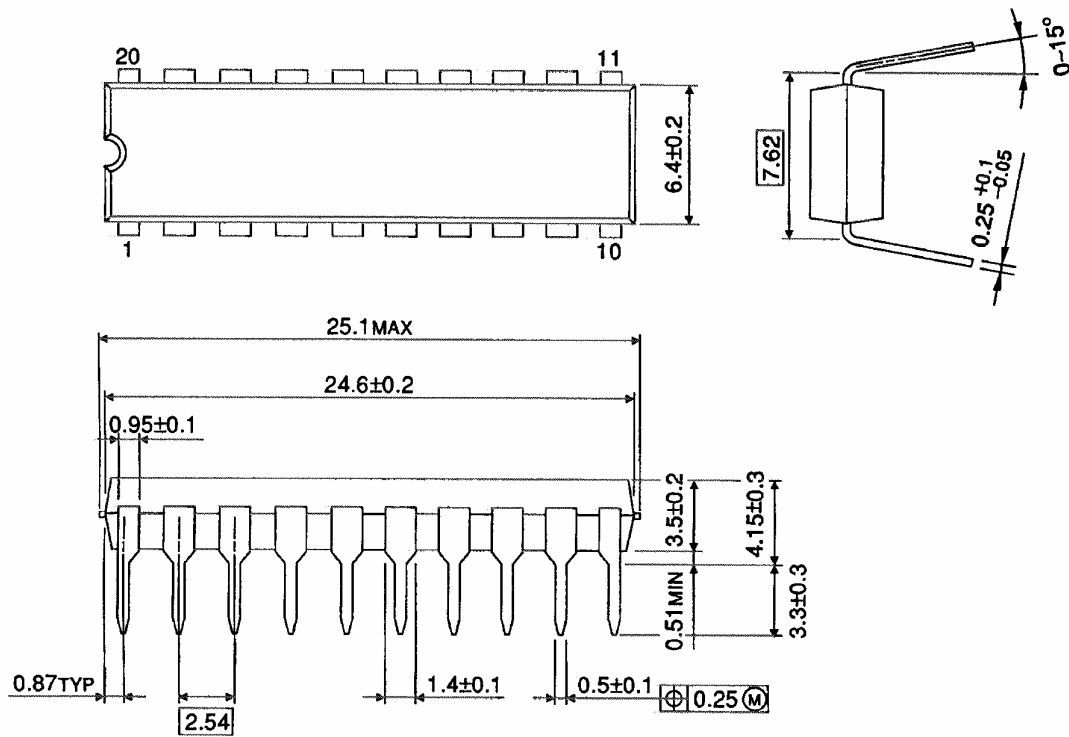

Weight: 1.30 g (typ.)

Package Dimensions

SOP20-P-300-1.27A

Unit: mm

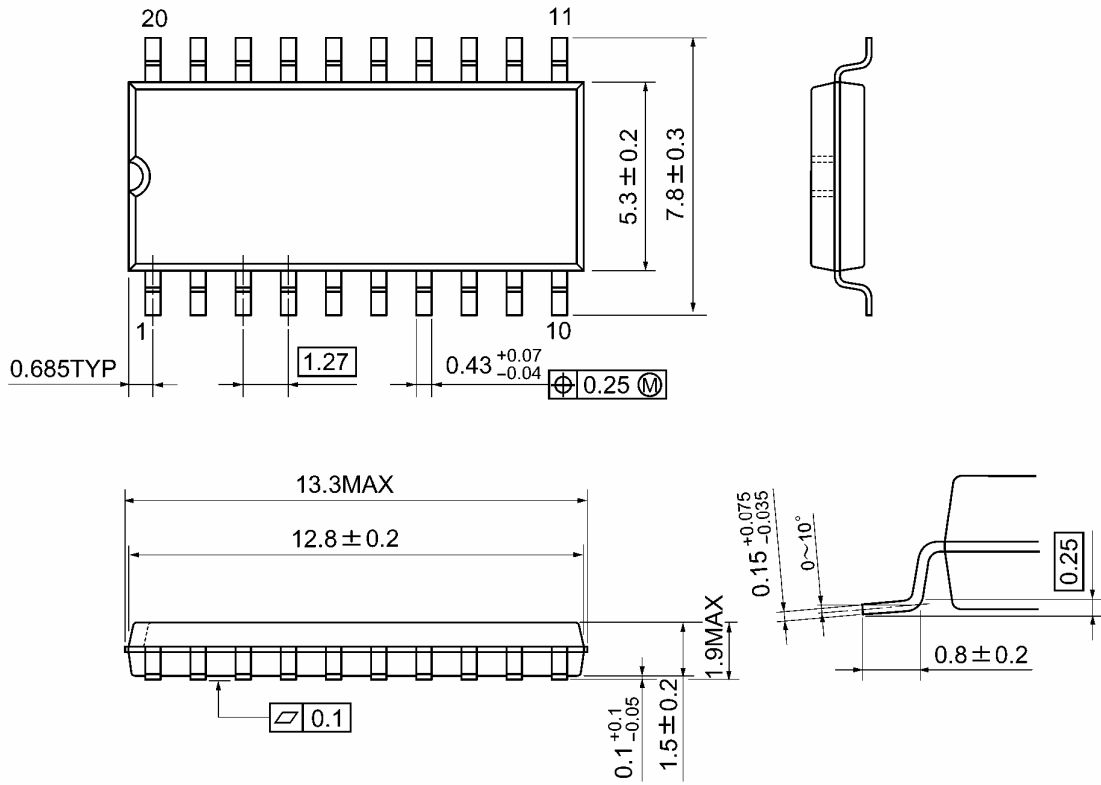

Weight: 0.22 g (typ.)

Package Dimensions

SOP20-P-300-1.27

Unit : mm

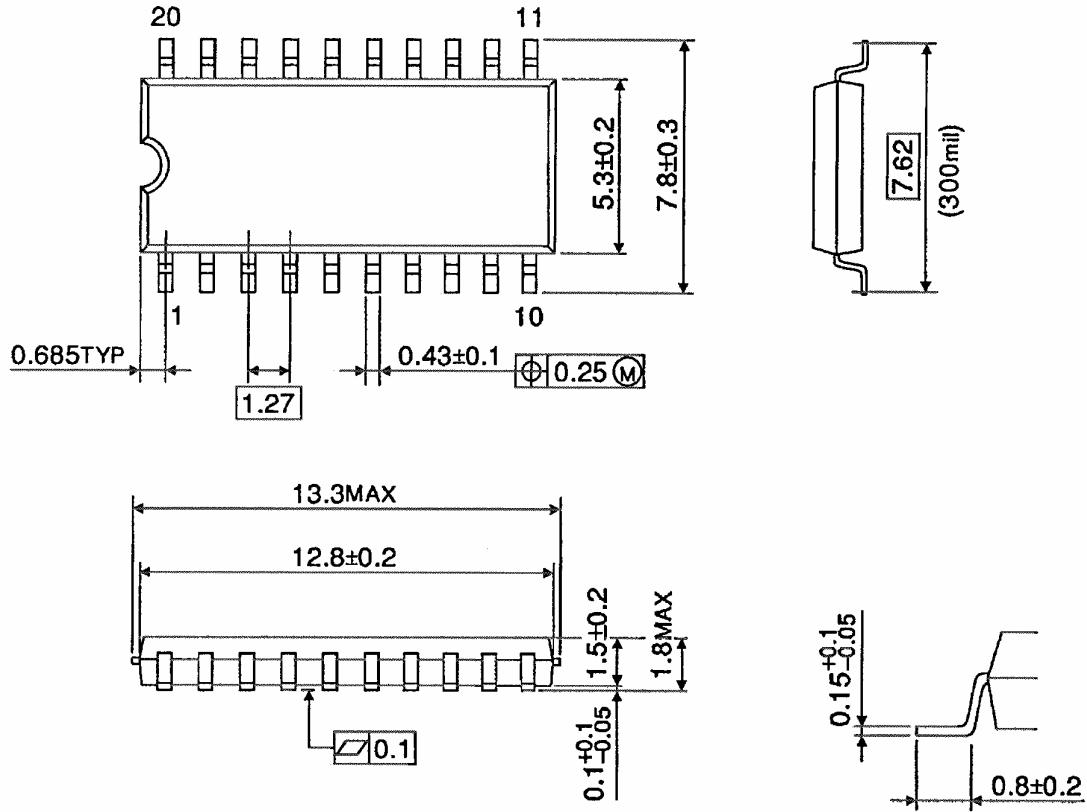

Weight: 0.22 g (typ.)

Package Dimensions (Note)

SOL20-P-300-1.27

Unit : mm

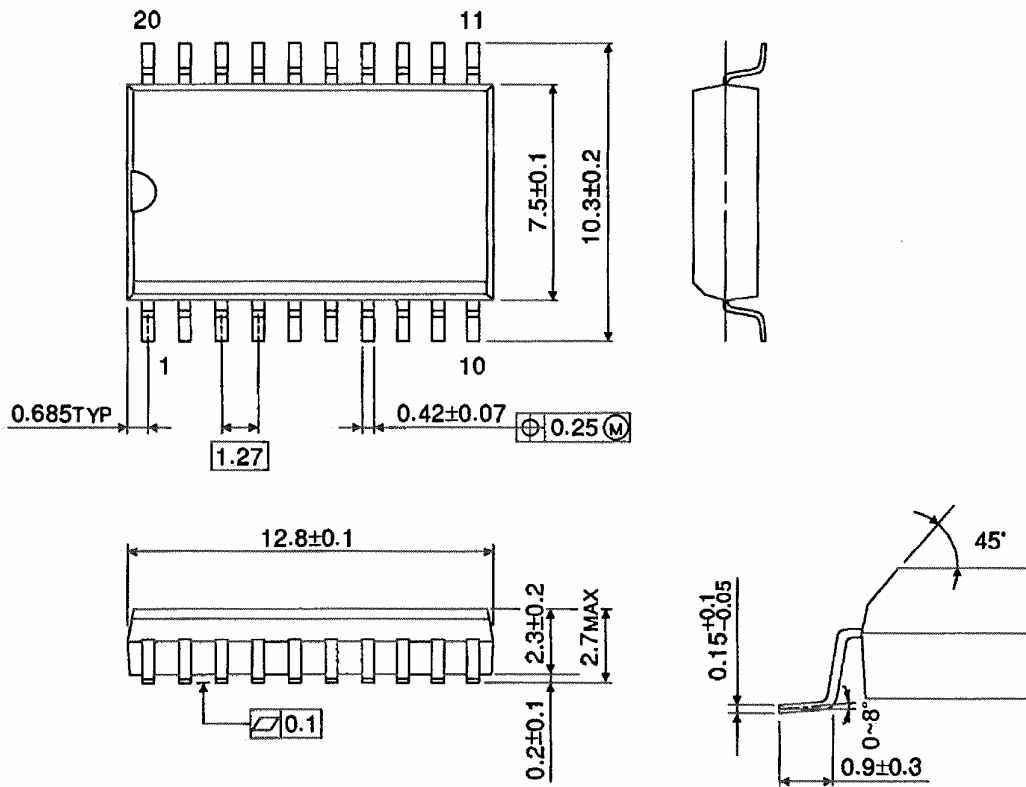

Note: This package is not available in Japan.

Weight: 0.46 g (typ.)

Package Dimensions

TSSOP20-P-0044-0.65A

Unit: mm

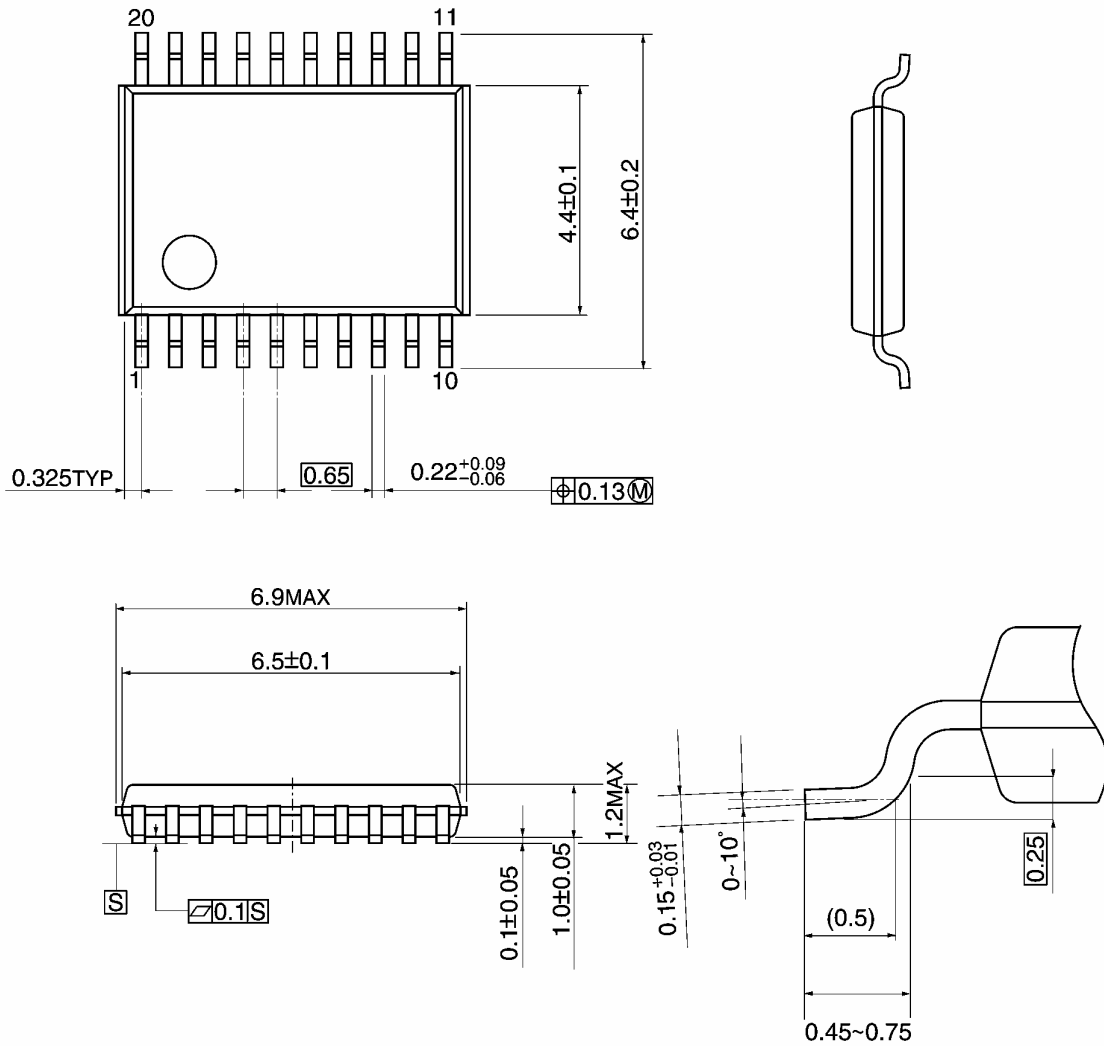

Weight: 0.08 g (typ.)

RESTRICTIONS ON PRODUCT USE

070122EBA

- The information contained herein is subject to change without notice. 021023_D
- TOSHIBA is continually working to improve the quality and reliability of its products. Nevertheless, semiconductor devices in general can malfunction or fail due to their inherent electrical sensitivity and vulnerability to physical stress. It is the responsibility of the buyer, when utilizing TOSHIBA products, to comply with the standards of safety in making a safe design for the entire system, and to avoid situations in which a malfunction or failure of such TOSHIBA products could cause loss of human life, bodily injury or damage to property.
In developing your designs, please ensure that TOSHIBA products are used within specified operating ranges as set forth in the most recent TOSHIBA products specifications. Also, please keep in mind the precautions and conditions set forth in the "Handling Guide for Semiconductor Devices," or "TOSHIBA Semiconductor Reliability Handbook" etc. 021023_A
- The TOSHIBA products listed in this document are intended for usage in general electronics applications (computer, personal equipment, office equipment, measuring equipment, industrial robotics, domestic appliances, etc.). These TOSHIBA products are neither intended nor warranted for usage in equipment that requires extraordinarily high quality and/or reliability or a malfunction or failure of which may cause loss of human life or bodily injury ("Unintended Usage"). Unintended Usage include atomic energy control instruments, airplane or spaceship instruments, transportation instruments, traffic signal instruments, combustion control instruments, medical instruments, all types of safety devices, etc. Unintended Usage of TOSHIBA products listed in this document shall be made at the customer's own risk. 021023_B
- The products described in this document shall not be used or embedded to any downstream products of which manufacture, use and/or sale are prohibited under any applicable laws and regulations. 060106_Q
- The information contained herein is presented only as a guide for the applications of our products. No responsibility is assumed by TOSHIBA for any infringements of patents or other rights of the third parties which may result from its use. No license is granted by implication or otherwise under any patents or other rights of TOSHIBA or the third parties. 070122_C
- The products described in this document are subject to foreign exchange and foreign trade control laws. 060925_E