

# WW420 CONNECTOR SYSTEM

.165" (4.2mm) pitch wire-to-wire (board) type

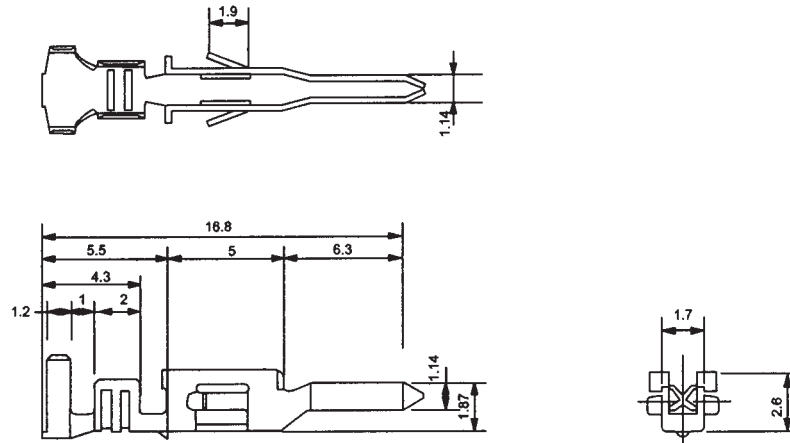

PART NO.	WIRE RANGE		MATERIAL/	THICKNESS	INSULATION	REEL
	AWG#	mm <sup>2</sup>	FINISH	mm	O.D.(mm)	PCS
WW420-MT	18-22	0.83-0.33	BRASS/TIN	0.25	3.0-1.7	5000

## WW420-F SERIES HOUSING

MATERIAL : NYLON 66 UL 94V-2  
 ACCEPT WW420-MT TERMINAL  
 MATE WITH WW420-M SERIES HOUSING  
 CURRENT RATING : 9A AC,DC  
 VOLTAGE RATING : 600V AC,DC  
 CONTACT RESISTANCE : 10mm Ω MAX  
 INSULATION RESISTANCE : 1000M Ω MIN  
 WITHSTANDING VOLTAGE : 1500V AC/MINUTE  
 TEMPERATURE RANGE : -25°C TO +85°C  
 APPLICABLE PANEL THICKNESS : 2.54 MAX

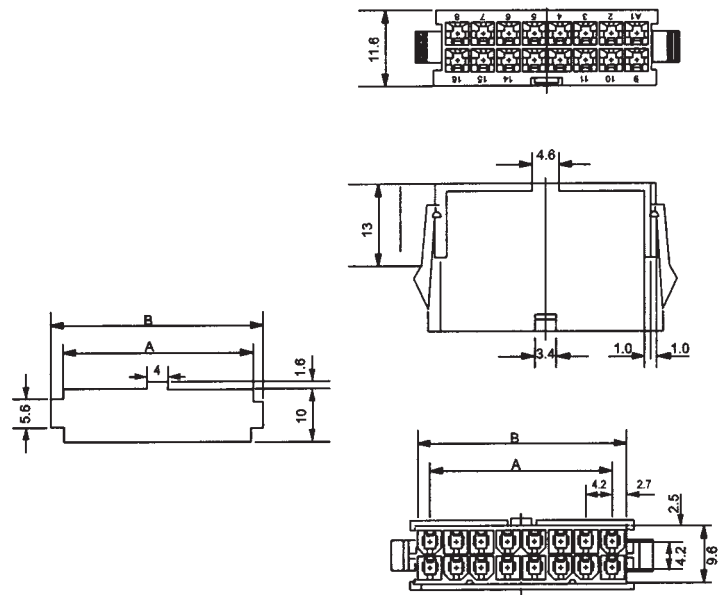

POLES	PART NO.	DIMENSIONS (mm)				POLES	PART NO.	DIMENSIONS (mm)			
		A	B	C	D			A	B	C	D
2	WW420-F02		5.4	5.8	10.8	14	WW420-F14	25.2	30.6	31.0	36.0
4	WW420-F04	4.2	9.6	10.0	15.0	16	WW420-F16	29.4	34.8	35.0	40.2
6	WW420-F06	8.4	13.8	14.2	19.2	18	WW420-F18	33.6	39.0	39.4	44.4
8	WW420-F08	12.6	18.0	18.4	23.4	20	WW420-F20	37.8	43.2	43.6	48.6
10	WW420-F10	16.8	22.2	22.6	27.6	22	WW420-F22	42.0	47.4	47.8	52.8
12	WW420-F12	21.0	26.4	26.8	31.8	24	WW420-F24	46.2	51.6	52.0	57.0

# WW420 CONNECTOR SYSTEM

.165" (4.2mm) pitch wire-to-wire (board) type

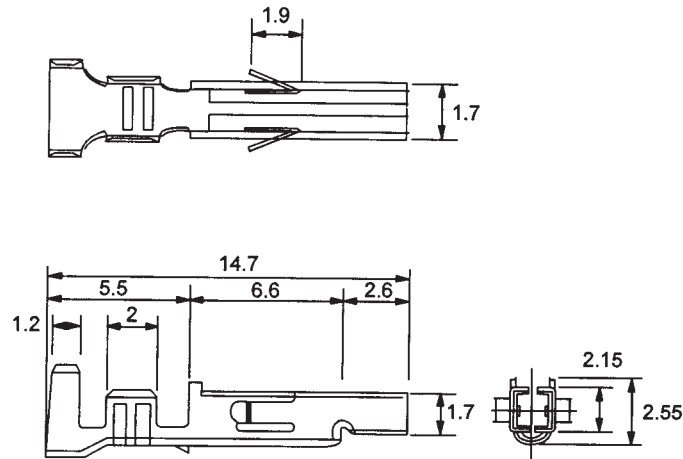

PART NO.	WIRE RANGE		MATERIAL/	THICKNESS	INSULATION	REEL
	AWG#	mm <sup>2</sup>	FINISH	mm	O.D.(mm)	PCS
WW420-FT	18-22	0.83-0.33	BRASS/TIN	0.25	3.0-1.7	5000

## WW420-M SERIES HOUSING

MATERIAL : NYLON 66 UL 94V-2  
 ACCEPT WW420-FT TERMINAL  
 MATE WITH WW420-F SERIES HOUSING  
 MATE WITH WW420-V(R) SERIES HEADER  
 CURRENT RATING : 9A AC,DC  
 VOLTAGE RATING : 600V AC,DC  
 CONTACT RESISTANCE : 10mΩ MAX  
 INSULATION RESISTANCE : 1000MΩ MIN  
 WITHSTANDING VOLTAGE : 1500V AC/MINUTE  
 TEMPERATURE RANGE : -25°C TO +85°C

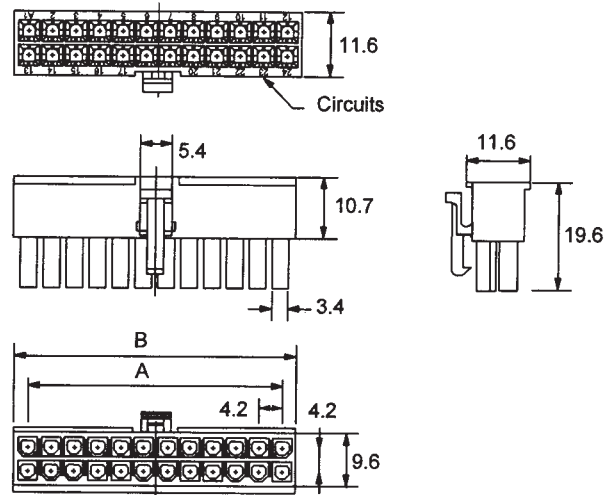

POLES	PART NO.	DIMENSIONS (mm)		POLES	PART NO.	DIMENSIONS (mm)	
		A	B			A	B
2	WW420-M02		5.4	14	WW420-M14	25.2	30.6
4	WW420-M04	4.2	9.6	16	WW420-M16	29.4	34.8
6	WW420-M06	8.4	13.8	18	WW420-M18	33.6	39.0
8	WW420-M08	12.6	18.0	20	WW420-M20	37.8	43.2
10	WW420-M10	19.8	22.2	22	WW420-M22	42.0	47.4
12	WW420-M12	21.0	26.4	24	WW420-M24	46.2	51.6

# WW420 CONNECTOR SYSTEM

.165" (4.2mm) pitch wire-to-wire (board) type



## WW420-V SERIES HEADER

MATERIAL : NYLON 66 UL 94V-2  
 PIN BRASS TIN/PLATED  
 MATE WITH WW420-M SERIES HOUSING  
 CURRENT RATING : 9A AC, DC  
 VOLTAGE RATING : 600V AC, DC  
 CONTACT RESISTANCE : 10m Ω MAX  
 INSULATION RESISTANCE : 1000M Ω MIN  
 WITHSTANDING VOLTAGE : 1500V AC/MINUTE  
 TEMPERATURE RANGE : -25°C TO +85°C

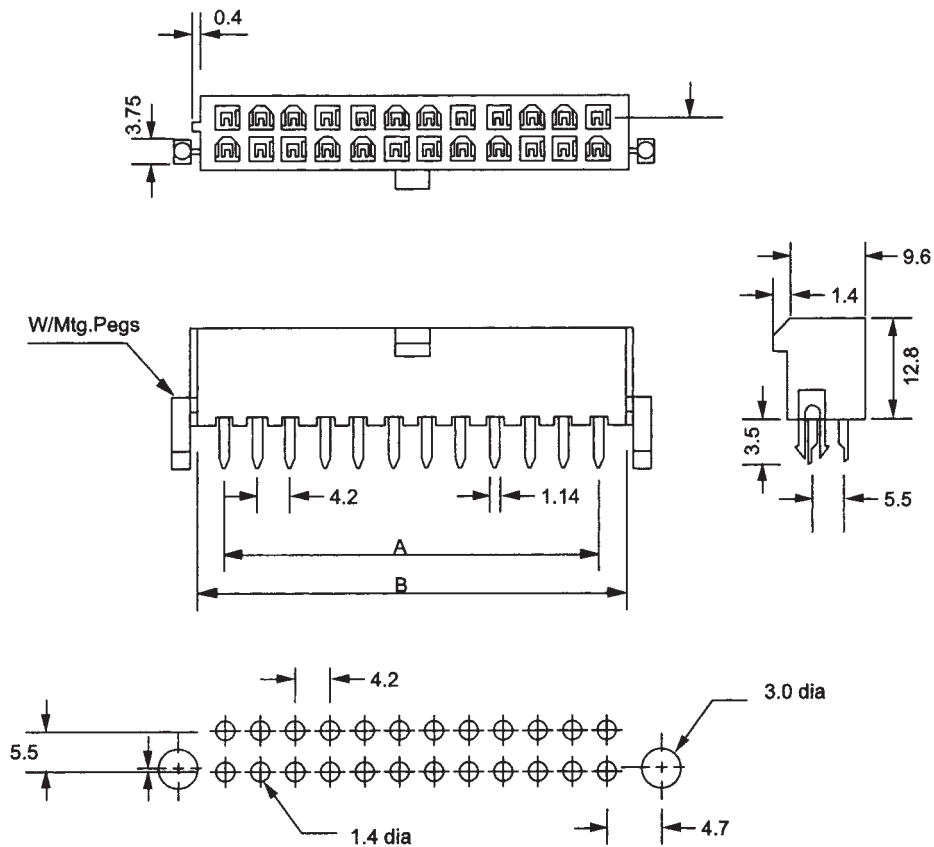

(P) : WITH PEGS

POLES	PART NO.	DIMENSIONS (mm)		POLES	PART NO.	DIMENSIONS (mm)	
		A	B			A	B
2	WW420-V02(P)		5.4	14	WW420-V14(P)	25.2	30.6
4	WW420-V04(P)	4.2	9.6	16	WW420-V16(P)	29.4	34.8
6	WW420-V06(P)	8.4	13.8	18	WW420-V18(P)	33.6	39.0
8	WW420-V08(P)	12.6	18.0	20	WW420-V20(P)	37.8	43.2
10	WW420-V10(P)	19.8	22.2	22	WW420-V22(P)	42.0	47.4
12	WW420-V12(P)	21.0	26.4	24	WW420-V24(P)	46.2	51.6