

REVISIONS			
LTR	DESCRIPTION	DATE (YR-MO-DA)	APPROVED
A	Changes in accordance with NOR 5962-R064-97.	96-11-18	Monica L. Poelking
B	Incorporate Revision A. Update boilerplate to MIL-PRF-38535 requirements. – LTG	01-10-02	Thomas M. Hess
C	Correct the title to accurately describe the device function. Update boilerplate to the latest MIL-PRF-38535 requirements. - jak	07-11-14	Thomas M. Hess

REV																				
SHEET																				
REV	C	C	C																	
SHEET	15	16	17																	
REV STATUS OF SHEETS				REV	C	C	C	C	C	C	C	C	C	C	C	C	C	C	C	
				SHEET	1	2	3	4	5	6	7	8	9	10	11	12	13	14		
PMIC N/A				PREPARED BY Thanh V. Nguyen					DEFENSE SUPPLY CENTER COLUMBUS COLUMBUS, OHIO 43218-3990 http://www.dsccl.dla.mil											
STANDARD MICROCIRCUIT DRAWING				CHECKED BY Thanh V. Nguyen																
THIS DRAWING IS AVAILABLE FOR USE BY ALL DEPARTMENTS AND AGENCIES OF THE DEPARTMENT OF DEFENSE AMSC N/A				APPROVED BY Monica L. Poelking					MICROCIRCUIT, DIGITAL, ADVANCED CMOS, RADIATION HARDENED, 1-OF-8 DATA SELECTOR/ MULTIPLEXER, MONOLITHIC SILICON											
				DRAWING APPROVAL DATE 96-04-19																
				REVISION LEVEL C					SIZE A	CAGE CODE 67268	5962-96548									
					SHEET 1 OF 17															

1. SCOPE

1.1 Scope. This drawing documents two product assurance class levels consisting of high reliability (device classes Q and M) and space application (device class V). A choice of case outlines and lead finishes are available and are reflected in the Part or Identifying Number (PIN). When available, a choice of Radiation Hardness Assurance (RHA) levels are reflected in the PIN.

1.2 PIN. The PIN is as shown in the following example:

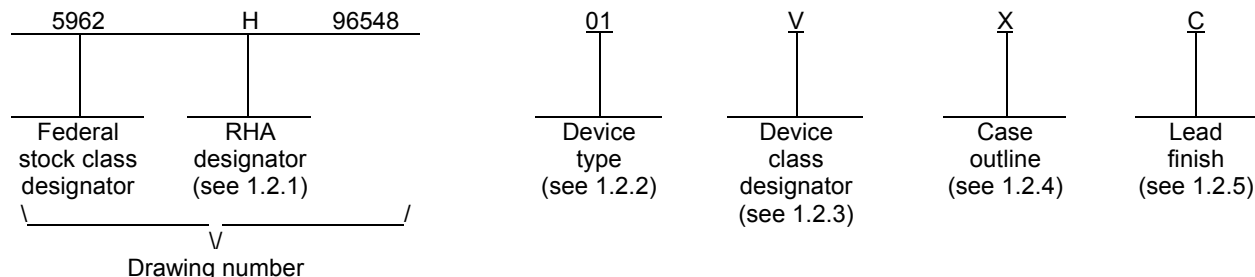

1.2.1 RHA designator. Device classes Q and V RHA marked devices meet the MIL-PRF-38535 specified RHA levels and are marked with the appropriate RHA designator. Device class M RHA marked devices meet the MIL-PRF-38535, appendix A specified RHA levels and are marked with the appropriate RHA designator. A dash (-) indicates a non-RHA device.

1.2.2 Device type(s). The device type(s) identify the circuit function as follows:

<u>Device type</u>	<u>Generic number</u>	<u>Circuit function</u>
01	54ACS151	Radiation hardened, 1-of-8 data selector/multiplexer

1.2.3 Device class designator. The device class designator is a single letter identifying the product assurance level as follows:

<u>Device class</u>	<u>Device requirements documentation</u>
M	Vendor self-certification to the requirements for MIL-STD-883 compliant, non-JAN class level B microcircuits in accordance with MIL-PRF-38535, appendix A
Q or V	Certification and qualification to MIL-PRF-38535

1.2.4 Case outlines. The case outlines are as designated in MIL-STD-1835 and as follows:

<u>Outline letter</u>	<u>Descriptive designator</u>	<u>Terminals</u>	<u>Package style</u>
E	GDIP1-T16 or CDIP2-T16	16	Dual-in-line
X	CDFP4-F16	16	Dual flat pack

1.2.5 Lead finish. The lead finish is as specified in MIL-PRF-38535 for device classes Q and V or MIL-PRF-38535, appendix A for device class M.

STANDARD MICROCIRCUIT DRAWING DEFENSE SUPPLY CENTER COLUMBUS COLUMBUS, OHIO 43218-3990	SIZE A		5962-96548
		REVISION LEVEL C	SHEET 2

1.3 Absolute maximum ratings. 1/ 2/ 3/

Supply voltage range (V _{DD}).....	-0.3 V dc to +7.0 V dc
DC input voltage range (V _{IN}).....	-0.3 V dc to V _{DD} + 0.3 V dc
DC output voltage range (V _{OUT}).....	-0.3 V dc to V _{DD} + 0.3 V dc
DC input current, any one input (I _{IN})	±10 mA
Latch-up immunity current (I _{LU}).....	±150 mA
Storage temperature range (T _{STG}).....	-65°C to +150°C
Lead temperature (soldering, 5 seconds).....	+300°C
Thermal resistance, junction-to-case (θ _{JC}).....	See MIL-STD-1835
Junction temperature (T _J).....	+175°C
Maximum package power dissipation (P _D)	1.0 W

1.4 Recommended operating conditions. 2/ 3/

Supply voltage range (V _{DD}).....	+4.5 V dc to +5.5 V dc
Input voltage range (V _{IN}).....	+0.0 V dc to V _{DD}
Output voltage range (V _{OUT})	+0.0 V dc to V _{DD}
Case operating temperature range (T _C)	-55°C to +125°C
Maximum input rise or fall time at V _{DD} = 4.5 V (t _r , t _f).....	1 ns/V 4/

1.5 Radiation features. 5/

Maximum total dose available (dose rate = 50 – 300 rads (Si)/s):.....	> 1 x 10 ⁶ Rads (Si)
Single event phenomenon (SEP) effective linear energy threshold (LET) No upsets (see 4.4.4.4).....	> 80 MeV/(mg/cm ²) 6/
Dose rate upset (20 ns pulse)	> 1 x 10 ⁹ Rads (Si)/s 6/
Latch-up.....	None 6/
Dose rate survivability.....	> 1 x 10 ¹² Rads (Si)/s 6/

- 1/ Stresses above the absolute maximum rating may cause permanent damage to the device. Extended operation at the maximum levels may degrade performance and affect reliability.
- 2/ Unless otherwise noted, all voltages are referenced to V_{SS}.
- 3/ The limits for the parameters specified herein shall apply over the full specified V_{DD} range and case temperature range of -55°C to +125°C unless otherwise noted.
- 4/ Derate system propagation delays by difference in rise time to switch point for t_r or t_f > 1 ns/V.
- 5/ Radiation testing is performed on the standard evaluation circuit.
- 6/ Limits are guaranteed by design or process but not production tested unless specified by the customer through the purchase order or contract.

STANDARD MICROCIRCUIT DRAWING DEFENSE SUPPLY CENTER COLUMBUS COLUMBUS, OHIO 43218-3990	SIZE A		5962-96548
		REVISION LEVEL C	SHEET 3

2. APPLICABLE DOCUMENTS

2.1 Government specification, standards, and handbooks. The following specification, standards, and handbooks form a part of this drawing to the extent specified herein. Unless otherwise specified, the issues of these documents are those cited in the solicitation or contract.

DEPARTMENT OF DEFENSE SPECIFICATION

MIL-PRF-38535 - Integrated Circuits, Manufacturing, General Specification for.

DEPARTMENT OF DEFENSE STANDARDS

MIL-STD-883 - Test Method Standard Microcircuits.

MIL-STD-1835 - Interface Standard Electronic Component Case Outlines.

DEPARTMENT OF DEFENSE HANDBOOKS

MIL-HDBK-103 - List of Standard Microcircuit Drawings.

MIL-HDBK-780 - Standard Microcircuit Drawings.

(Copies of these documents are available online at <http://assist.daps.dla.mil/quicksearch/> or <http://assist.daps.dla.mil> or from the Standardization Document Order Desk, 700 Robbins Avenue, Building 4D, Philadelphia, PA 19111-5094.)

2.2 Non-Government publications. The following document(s) form a part of this document to the extent specified herein. Unless otherwise specified, the issues of these documents are those cited in the solicitation or contract.

AMERICAN SOCIETY FOR TESTING AND MATERIALS (ASTM)

ASTM F1192 - Standard Guide for the Measurement of Single Event Phenomena (SEP) Induced by Heavy Ion Irradiation of semiconductor Devices.

(Copies of these documents are available online at <http://www.astm.org> or from ASTM International, 100 Barr Harbor Drive, P.O. Box C700, West Conshohocken, PA, 19428-2959).

2.3 Order of precedence. In the event of a conflict between the text of this drawing and the references cited herein, the text of this drawing takes precedence. Nothing in this document, however, supersedes applicable laws and regulations unless a specific exemption has been obtained.

3. REQUIREMENTS

3.1 Item requirements. The individual item requirements for device classes Q and V shall be in accordance with MIL-PRF-38535 and as specified herein or as modified in the device manufacturer's Quality Management (QM) plan. The modification in the QM plan shall not affect the form, fit, or function as described herein. The individual item requirements for device class M shall be in accordance with MIL-PRF-38535, appendix A for non-JAN class level B devices and as specified herein.

3.2 Design, construction, and physical dimensions. The design, construction, and physical dimensions shall be as specified in MIL-PRF-38535 and herein for device classes Q and V or MIL-PRF-38535, appendix A and herein for device class M.

3.2.1 Case outlines. The case outlines shall be in accordance with 1.2.4 herein.

3.2.2 Terminal connections. The terminal connections shall be as specified on figure 1.

3.2.3 Truth table. The truth table shall be as specified on figure 2.

3.2.4 Logic diagram. The logic diagram shall be as specified on figure 3.

3.2.5 Switching waveforms and test circuits. The switching waveforms and test circuits shall be as specified on figure 4.

3.2.6 Irradiation test connections. The irradiation test connections shall be as specified in table III.

STANDARD MICROCIRCUIT DRAWING DEFENSE SUPPLY CENTER COLUMBUS COLUMBUS, OHIO 43218-3990	SIZE A		5962-96548
		REVISION LEVEL C	SHEET 4

3.3 Electrical performance characteristics and postirradiation parameter limits. Unless otherwise specified herein, the electrical performance characteristics and postirradiation parameter limits are as specified in table IA and shall apply over the full case operating temperature range.

3.4 Electrical test requirements. The electrical test requirements shall be the subgroups specified in table IIA. The electrical tests for each subgroup are described in table IA.

3.5 Marking. The part shall be marked with the PIN listed in 1.2 herein. In addition, the manufacturer's PIN may also be marked. For packages where marking of the entire SMD PIN number is not feasible due to space limitations, the manufacturer has the option of not marking the "5962-" on the device. For RHA product using this option, the RHA designator shall still be marked. Marking for device classes Q and V shall be in accordance with MIL-PRF-38535. Marking for device class M shall be in accordance with MIL-PRF-38535, appendix A.

3.5.1 Certification/compliance mark. The certification mark for device classes Q and V shall be a "QML" or "Q" as required in MIL-PRF-38535. The compliance mark for device class M shall be a "C" as required in MIL-PRF-38535, appendix A.

3.6 Certificate of compliance. For device classes Q and V, a certificate of compliance shall be required from a QML-38535 listed manufacturer in order to supply to the requirements of this drawing (see 6.6.1 herein). For device class M, a certificate of compliance shall be required from a manufacturer in order to be listed as an approved source of supply in MIL-HDBK-103 (see 6.6.2 herein). The certificate of compliance submitted to DSCC-VA prior to listing as an approved source of supply for this drawing shall affirm that the manufacturer's product meets, for device classes Q and V, the requirements of MIL-PRF-38535 and herein or for device class M, the requirements of MIL-PRF-38535, appendix A and herein.

3.7 Certificate of conformance. A certificate of conformance as required for device classes Q and V in MIL-PRF-38535 or for device class M in MIL-PRF-38535, appendix A shall be provided with each lot of microcircuits delivered to this drawing.

3.8 Notification of change for device class M. For device class M, notification to DSCC-VA of change of product (see 6.2 herein) involving devices acquired to this drawing is required for any change that affects this drawing.

3.9 Verification and review for device class M. For device class M, DSCC, DSCC's agent, and the acquiring activity retain the option to review the manufacturer's facility and applicable required documentation. Offshore documentation shall be made available onshore at the option of the reviewer.

3.10 Microcircuit group assignment for device class M. Device class M devices covered by this drawing shall be in microcircuit group number 39 (see MIL-PRF-38535, appendix A).

STANDARD MICROCIRCUIT DRAWING DEFENSE SUPPLY CENTER COLUMBUS COLUMBUS, OHIO 43218-3990	SIZE A		5962-96548
		REVISION LEVEL C	SHEET 5

TABLE IA. Electrical performance characteristics.

Test	Symbol	Test conditions <u>1/</u> -55°C ≤ T _C ≤ +125°C unless otherwise specified	Device type	V _{DD}	Group A subgroups	Limits <u>2/</u>		Unit
						Min	Max	
High level input voltage	V _{IH}		All	4.5 V	1, 2, 3	3.15		V
			M, D, P, L, R, F, G, H <u>3/</u>		All	1	3.15	
			All	5.5 V	1, 2, 3	3.85		
			M, D, P, L, R, F, G, H <u>3/</u>		All	1	3.85	
Low level input voltage	V _{IL}		All	4.5 V	1, 2, 3		1.35	V
			M, D, P, L, R, F, G, H <u>3/</u>		All	1	1.35	
			All	5.5 V	1, 2, 3		1.65	
			M, D, P, L, R, F, G, H <u>3/</u>		All	1	1.65	
High level output voltage	V _{OH}	For all inputs affecting output under test, V _{IN} = V _{DD} or V _{SS} I _{OH} = -100.0 μA	All	4.5 V	1, 2, 3	4.25		V
			M, D, P, L, R, F, G, H <u>3/</u>		All	1	4.25	
Low level output voltage	V _{OL}	For all inputs affecting output under test, V _{IN} = V _{DD} or V _{SS} I _{OL} = 100.0 μA	All	4.5 V	1, 2, 3		0.25	V
			M, D, P, L, R, F, G, H <u>3/</u>		All	1	0.25	
Input current high	I _{IH}	For input under test, V _{IN} = 5.5 V For all other inputs V _{IN} = V _{DD} or V _{SS}	All	5.5 V	1, 2, 3		+1.0	μA
			M, D, P, L, R, F, G, H <u>3/</u>		All	1	+1.0	
Input current low	I _{IL}	For input under test, V _{IN} = V _{SS} For all other inputs V _{IN} = V _{DD} or V _{SS}	All	5.5 V	1, 2, 3		-1.0	μA
			M, D, P, L, R, F, G, H <u>3/</u>		All	1	-1.0	
Output current (Sink)	I _{OL} <u>4/</u>	V _{IN} = V _{DD} or V _{SS} , V _{OL} = 0.4 V	All	4.5 V and 5.5 V	1, 2, 3	8.0		mA
Output current (Source)	I _{OH} <u>4/</u>	V _{IN} = V _{DD} or V _{SS} , V _{OH} = V _{DD} - 0.4 V	All	4.5 V and 5.5 V	1, 2, 3	-8.0		mA

See footnotes at end of table.

STANDARD MICROCIRCUIT DRAWING DEFENSE SUPPLY CENTER COLUMBUS COLUMBUS, OHIO 43218-3990	SIZE A		5962-96548
		REVISION LEVEL C	SHEET 6

TABLE IA. Electrical performance characteristics – Continued.

Test	Symbol	Test conditions ^{1/} -55°C ≤ T _C ≤ +125°C unless otherwise specified	Device type	V _{DD}	Group A subgroups	Limits ^{2/}		Unit
						Min	Max	
Quiescent supply current	I _{DDQ}	V _{IN} = V _{DD} or V _{SS}	All	5.5 V	1, 2, 3		10.0	μA
		M, D, P, L, R, F, G, H ^{3/}	All		1		10.0	
Short circuit output current	I _{OS} ^{5/ 6/}	V _{OUT} = V _{DD} and V _{SS}	All	5.5 V	1, 2, 3	-200	200	mA
Input capacitance	C _{IN}	f = 1 MHz, see 4.4.1c	All	0.0 V	4		15.0	pF
Output capacitance	C _{OUT}	f = 1 MHz, see 4.4.1c	All	0.0 V	4		15.0	pF
Switching power dissipation	P _{SW} ^{7/}	C _L = 50 pF, per switching output	All	4.5 V and 5.5 V	4, 5, 6		2.3	mW/MHz
Functional test	^{8/}	V _{IH} = 0.7 V _{DD} , V _{IL} = 0.3 V _{DD} See 4.4.1b	All	4.5 V and 5.5 V	7, 8	L	H	
		M, D, P, L, R, F, G, H ^{3/}	All		7	L	H	
Propagation delay time, Dn to Y	t _{PLH1} ^{9/}	C _L = 50 pF, see figure 4	All	4.5 V and 5.5 V	9, 10, 11	1.0	23.0	ns
		M, D, P, L, R, F, G, H ^{3/}	All		9	1.0	23.0	
	t _{PHL1} ^{9/}	C _L = 50 pF, see figure 4	All	4.5 V and 5.5 V	9, 10, 11	1.0	22.0	
		M, D, P, L, R, F, G, H ^{3/}	All		9	1.0	22.0	
Propagation delay time, Dn to Y	t _{PLH2} ^{9/}	C _L = 50 pF, see figure 4	All	4.5 V and 4.5 V	9, 10, 11	1.0	19.0	ns
		M, D, P, L, R, F, G, H ^{3/}	All		9	1.0	19.0	
	t _{PHL2} ^{9/}	C _L = 50 pF, see figure 4	All	4.5 V and 5.5 V	9, 10, 11	1.0	25.0	
		M, D, P, L, R, F, G, H ^{3/}	All		9	1.0	25.0	
Propagation delay time, select to Y	t _{PLH3} ^{9/}	C _L = 50 pF, see figure 4	All	4.5 V and 4.5 V	9, 10, 11	1.0	22.0	ns
		M, D, P, L, R, F, G, H ^{3/}	All		9	1.0	22.0	
	t _{PHL3} ^{9/}	C _L = 50 pF, see figure 4	All	4.5 V and 5.5 V	9, 10, 11	1.0	21.0	
		M, D, P, L, R, F, G, H ^{3/}	All		9	1.0	21.0	

See footnotes at end of table.

STANDARD MICROCIRCUIT DRAWING DEFENSE SUPPLY CENTER COLUMBUS COLUMBUS, OHIO 43218-3990	SIZE A		5962-96548
		REVISION LEVEL C	SHEET 7

TABLE IA. Electrical performance characteristics – Continued.

Test	Symbol	Test conditions ^{1/} -55°C ≤ T _C ≤ +125°C unless otherwise specified	Device type	V _{DD}	Group A subgroups	Limits ^{2/}		Unit
						Min	Max	
Propagation delay time, select to \bar{Y}	t _{PLH4} ^{9/}	C _L = 50 pF, see figure 4 M, D, P, L, R, F, G, H ^{3/}	All	4.5 V and 5.5 V	9, 10, 11	1.0	21.0	ns
			All		9	1.0	21.0	
	t _{PHL4} ^{9/}	C _L = 50 pF, see figure 4 M, D, P, L, R, F, G, H ^{3/}	All	4.5 V and 5.5 V	9, 10, 11	1.0	24.0	
			All		9	1.0	24.0	
Propagation delay time, G to Y	t _{PLH5} ^{9/}	C _L = 50 pF, see figure 4 M, D, P, L, R, F, G, H ^{3/}	All	4.5 V and 4.5 V	9, 10, 11	1.0	11.0	ns
			All		9	1.0	11.0	
	t _{PHL5} ^{9/}	C _L = 50 pF, see figure 4 M, D, P, L, R, F, G, H ^{3/}	All	4.5 V and 5.5 V	9, 10, 11	1.0	14.0	
			All		9	1.0	14.0	
Propagation delay time, G to \bar{Y}	t _{PLH6} ^{9/}	C _L = 50 pF, see figure 4 M, D, P, L, R, F, G, H ^{3/}	All	4.5 V and 4.5 V	9, 10, 11	1.0	10.0	ns
			All		9	1.0	10.0	
	t _{PHL6} ^{9/}	C _L = 50 pF, see figure 4 M, D, P, L, R, F, G, H ^{3/}	All	4.5 V and 5.5 V	9, 10, 11	1.0	14.0	
			All		9	1.0	14.0	

- ^{1/} Each input/output, as applicable, shall be tested at the specified temperature, for the specified limits, to the tests in table IA herein. Output terminals not designated shall be high level logic, low level logic, or open, except for the I_{DDQ} test, the output terminals shall be open. When performing the I_{DDQ} test, the current meter shall be placed in the circuit such that all current flows through the meter.
- ^{2/} For negative and positive voltage and current values, the sign designates the potential difference in reference to V_{SS} and the direction of current flow respectively; and the absolute value of the magnitude, not the sign, is relative to the minimum and maximum limits, as applicable, listed herein.
- ^{3/} RHA parts supplied to this drawing have been characterized through all levels M, D, P, L, R, F, G, and H of irradiation. However, this device is only tested at the 'H' level. Pre and Post irradiation values are identical unless otherwise specified in table IA. When performing post irradiation electrical measurements for any RHA level, T_A = +25°C.
- ^{4/} This test is guaranteed based on characterization data but not tested.
- ^{5/} This parameter is supplied as design limit but not guaranteed or tested.
- ^{6/} No more than one output should be shorted at a time for a maximum duration of one second.
- ^{7/} This value is calculated during the design/qualification process and is supplied as a design limit but is not tested.
- ^{8/} The test vectors used to verify the truth table shall, at a minimum, test all functions of each input and output. All possible input to output logic patterns per function shall be guaranteed, if not tested, to the truth table in figure 2 herein. For V_{OUT} measurements, L ≤ 0.5 V and H ≥ 4.0 V and are tested at V_{DD} = 4.5 V and V_{DD} = 5.5 V.
- ^{9/} For propagation delay tests, all paths must be tested.

STANDARD MICROCIRCUIT DRAWING DEFENSE SUPPLY CENTER COLUMBUS COLUMBUS, OHIO 43218-3990	SIZE A		5962-96548
		REVISION LEVEL C	SHEET 8

TABLE IB. SEP test limits. 1/ 2/

Device type	$V_{DD} = 4.5 \text{ V}$ <u>3/</u>		Bias for latch-up test $V_{DD} = 5.5 \text{ V}$ no latch-up LET = <u>4/</u> <u>5/</u>
	Effective LET no upsets [MeV/(mg/cm ²)]	Maximum device cross section	
All	LET ≥ 80	$6 \times 10^{-9} \text{ cm}^2/\text{bit}$	≥ 80

- 1/ For SEP test conditions, see 4.4.4.4 herein.
- 2/ Technology characterization and model verification supplemented by in-line data may be used in lieu of end-of-line testing. Test plan must be approved by TRB and qualifying activity.
- 3/ Tested for upsets at worse case temperature, $T_A = +25^\circ\text{C} \pm 10^\circ\text{C}$.
- 4/ Tested at worst case temperature, $T_A \geq +125^\circ\text{C} \pm 10^\circ\text{C}$ for latch-up.
- 5/ Tested to a LET of $\geq 120 \text{ MeV}/(\text{mg}/\text{cm}^2)$ with no latch-up (SEL).

STANDARD MICROCIRCUIT DRAWING DEFENSE SUPPLY CENTER COLUMBUS COLUMBUS, OHIO 43218-3990	SIZE A		5962-96548
		REVISION LEVEL C	SHEET 9

Device type	All		
Case outlines	E and X		
Terminal number	Terminal symbol	Terminal number	Terminal symbol
1	D3	9	C
2	D2	10	B
3	D1	11	A
4	D0	12	D7
5	Y	13	D6
6	\overline{Y}	14	D5
7	\overline{G}	15	D4
8	V _{SS}	16	V _{DD}

FIGURE 1. Terminal connections.

Enable inputs	Select inputs			Outputs	
	\overline{G}	C	B	A	Y
H	X	X	X	L	H
L	L	L	L	D0	$\overline{D0}$
L	L	L	H	D1	$\overline{D1}$
L	L	H	L	D2	$\overline{D2}$
L	L	H	H	D3	$\overline{D3}$
L	H	L	L	D4	$\overline{D4}$
L	H	L	H	D5	$\overline{D5}$
L	H	H	L	D6	$\overline{D6}$
L	H	H	H	D7	$\overline{D7}$

H = High voltage level
L = Low voltage level
X = Irrelevant

FIGURE 2. Truth table.

STANDARD MICROCIRCUIT DRAWING DEFENSE SUPPLY CENTER COLUMBUS COLUMBUS, OHIO 43218-3990	SIZE A		5962-96548
		REVISION LEVEL C	SHEET 10

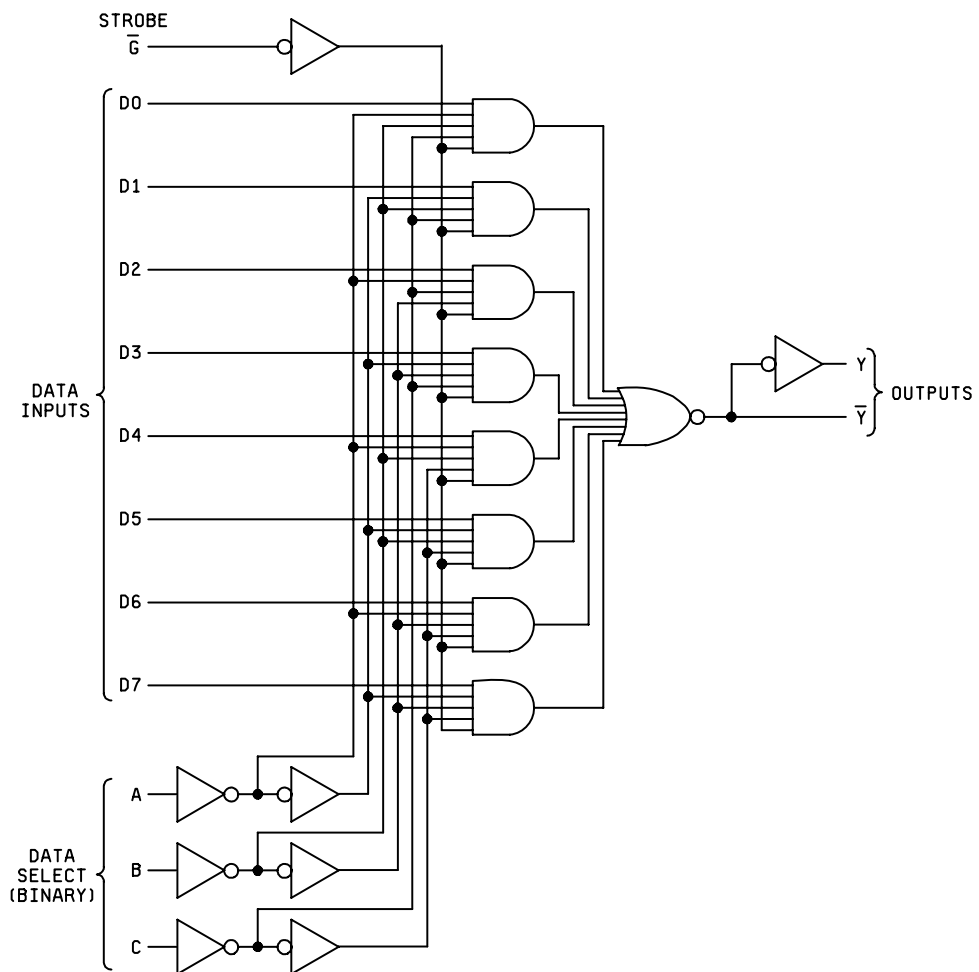
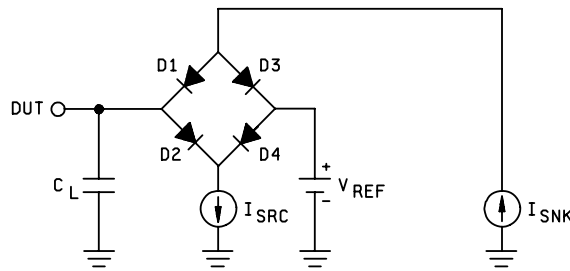
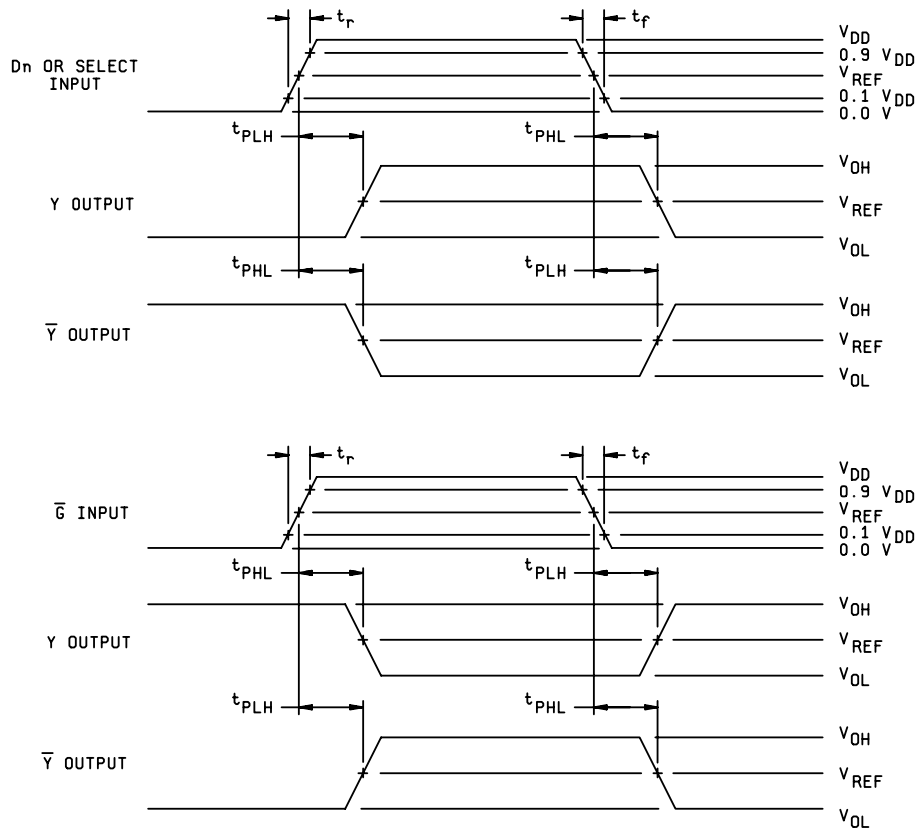

FIGURE 3. Logic diagram.

STANDARD MICROCIRCUIT DRAWING DEFENSE SUPPLY CENTER COLUMBUS COLUMBUS, OHIO 43218-3990	SIZE A		5962-96548
		REVISION LEVEL C	SHEET 11



NOTES:

- 1/ $V_{REF} = V_{DD}/2$.
- 2/ $C_L = 50 \text{ pF}$ minimum or equivalent (includes test jig and probe capacitance).
- 3/ I_{SRC} is set to -1.0 mA and I_{SNK} is set to 1.0 mA for t_{PHL} and t_{PLH} measurements.
- 4/ Input signal from pulse generator: $V_{IN} = 0.0 \text{ V}$ to V_{DD} ; $f \leq 10 \text{ MHz}$; $t_r = 1.0 \text{ V/ns} \pm 0.3 \text{ V/ns}$; $t_f = 1.0 \text{ V/ns} \pm 0.3 \text{ V/ns}$; t_r and t_f shall be measured from $0.1 V_{DD}$ to $0.9 V_{DD}$ and from $0.9 V_{DD}$ to $0.1 V_{DD}$, respectively.

FIGURE 4. Switching waveforms and test circuit.

STANDARD MICROCIRCUIT DRAWING DEFENSE SUPPLY CENTER COLUMBUS COLUMBUS, OHIO 43218-3990	SIZE A		5962-96548
		REVISION LEVEL C	SHEET 12

4. VERIFICATION

4.1 Sampling and inspection. For device classes Q and V, sampling and inspection procedures shall be in accordance with MIL-PRF-38535 or as modified in the device manufacturer's Quality Management (QM) plan. The modification in the QM plan shall not affect the form, fit, or function as described herein. For device class M, sampling and inspection procedures shall be in accordance with MIL-PRF-38535, appendix A.

4.2 Screening. For device classes Q and V, screening shall be in accordance with MIL-PRF-38535, and shall be conducted on all devices prior to qualification and technology conformance inspection. For device class M, screening shall be in accordance with method 5004 of MIL-STD-883, and shall be conducted on all devices prior to quality conformance inspection.

4.2.1 Additional criteria for device class M.

a. Burn-in test, method 1015 of MIL-STD-883.

(1) Test condition A, B, C, or D. The test circuit shall be maintained by the manufacturer under document revision level control and shall be made available to the preparing or acquiring activity upon request. The test circuit shall specify the inputs, outputs, biases, and power dissipation, as applicable, in accordance with the intent specified in method 1015 of MIL-STD-883.

(2) $T_A = +125^{\circ}\text{C}$, minimum.

b. Interim and final electrical test parameters shall be as specified in table IIA herein.

4.2.2 Additional criteria for device classes Q and V.

a. The burn-in test duration, test condition and test temperature, or approved alternatives shall be as specified in the device manufacturer's QM plan in accordance with MIL-PRF-38535. The burn-in test circuit shall be maintained under document revision level control of the device manufacturer's Technology Review Board (TRB) in accordance with MIL-PRF-38535 and shall be made available to the acquiring or preparing activity upon request. The test circuit shall specify the inputs, outputs, biases, and power dissipation, as applicable, in accordance with the intent specified in method 1015 of MIL-STD-883.

b. Interim and final electrical test parameters shall be as specified in table IIA herein.

c. Additional screening for device class V beyond the requirements of device class Q shall be as specified in MIL-PRF-38535, appendix B.

4.3 Qualification inspection for device classes Q and V. Qualification inspection for device classes Q and V shall be in accordance with MIL-PRF-38535. Inspections to be performed shall be those specified in MIL-PRF-38535 and herein for groups A, B, C, D, and E inspections (see 4.4.1 through 4.4.4).

4.4 Conformance inspection. Technology conformance inspection for classes Q and V shall be in accordance with MIL-PRF-38535 including groups A, B, C, D, and E inspections and as specified herein. Quality conformance inspection for device class M shall be in accordance with MIL-PRF-38535, appendix A and as specified herein. Inspections to be performed for device class M shall be those specified in method 5005 of MIL-STD-883 and herein for groups A, B, C, D, and E inspections (see 4.4.1 through 4.4.4).

STANDARD MICROCIRCUIT DRAWING DEFENSE SUPPLY CENTER COLUMBUS COLUMBUS, OHIO 43218-3990	SIZE A		5962-96548
		REVISION LEVEL C	SHEET 13

4.4.1 Group A inspection.

- a. Tests shall be as specified in table IIA herein.
- b. For device class M, subgroups 7 and 8 tests shall be sufficient to verify the truth table. For device classes Q and V subgroups 7 and 8 shall include verifying the functionality of the device.
- c. C_{IN} and C_{OUT} shall be measured only for the initial test and after process or design changes which may affect capacitance. C_{IN} shall be measured between the designated terminal and V_{SS} at a frequency of 1 MHz. For C_{IN} and C_{OUT} , test all applicable pins on five devices with zero failures.

4.4.2 Group C inspection. The group C inspection end-point electrical parameters shall be as specified in table IIA herein.

4.4.2.1 Additional criteria for device class M. Steady-state life test conditions, method 1005 of MIL-STD-883:

- a. Test condition A, B, C, or D. The test circuit shall be maintained by the manufacturer under document revision level control and shall be made available to the preparing or acquiring activity upon request. The test circuit shall specify the inputs, outputs, biases, and power dissipation, as applicable, in accordance with the intent specified in method 1005 of MIL-STD-883.
- b. $T_A = +125^{\circ}\text{C}$, minimum.
- c. Test duration: 1,000 hours, except as permitted by method 1005 of MIL-STD-883.

4.4.2.2 Additional criteria for device classes Q and V. The steady-state life test duration, test condition and test temperature, or approved alternatives shall be as specified in the device manufacturer's QM plan in accordance with MIL-PRF-38535. The test circuit shall be maintained under document revision level control by the device manufacturer's TRB in accordance with MIL-PRF-38535 and shall be made available to the acquiring or preparing activity upon request. The test circuit shall specify the inputs, outputs, biases, and power dissipation, as applicable, in accordance with the intent specified in method 1005 of MIL-STD-883.

4.4.3 Group D inspection. The group D inspection end-point electrical parameters shall be as specified in table IIA herein.

4.4.4 Group E inspection. Group E inspection is required only for parts intended to be marked as radiation hardness assured (see 3.5 herein).

- a. End-point electrical parameters shall be as specified in table IIA herein.
- b. For device classes Q and V, the devices or test vehicle shall be subjected to radiation hardness assured tests as specified in MIL-PRF-38535 for the RHA level being tested. For device class M, the devices shall be subjected to radiation hardness assured tests as specified in MIL-PRF-38535, appendix A for the RHA level being tested. All device classes must meet the postirradiation end-point electrical parameter limits as defined in table IA at $T_A = +25^{\circ}\text{C} \pm 5^{\circ}\text{C}$, after exposure, to the subgroups specified in table IIA herein.
- c. When specified in the purchase order or contract, a copy of the RHA delta limits shall be supplied.

4.4.4.1 Total dose irradiation testing. Total dose irradiation testing shall be performed in accordance with MIL-STD-883, method 1019, condition A and as specified herein.

4.4.4.1.1 Accelerated annealing test. Accelerated annealing tests shall be performed on all devices requiring a RHA level greater than 5k rads (Si). The post-anneal end-point electrical parameter limits shall be as specified in table IA herein and shall be the pre-irradiation end-point electrical parameter limit at $25^{\circ}\text{C} \pm 5^{\circ}\text{C}$. Testing shall be performed at initial qualification and after any design or process changes which may affect the RHA response of the device.

4.4.4.2 Dose rate induced latch-up testing. When required by the customer, dose rate induced latch-up testing shall be performed in accordance with method 1020 of MIL-STD-883 and as specified herein. Tests shall be performed on devices, SEC, or approved test structures at technology qualification and after any design or process changes which may affect the RHA capability of the process.

STANDARD MICROCIRCUIT DRAWING DEFENSE SUPPLY CENTER COLUMBUS COLUMBUS, OHIO 43218-3990	SIZE A		5962-96548
		REVISION LEVEL C	SHEET 14

4.4.4.3 Dose rate upset testing. When required by the customer, dose rate upset testing shall be performed in accordance with method 1021 of MIL-STD-883 and herein.

- a. Transient dose rate upset testing for class M devices shall be performed at initial qualification and after any design or process changes which may affect the RHA performance of the devices. Test 10 devices with 0 defects unless otherwise specified.
- b. Transient dose rate upset testing for class Q and V devices shall be performed as specified by a TRB approved radiation hardness assurance plan and MIL-PRF-38535. Device parametric parameters that influence upset immunity shall be monitored at the wafer level in accordance with the wafer level hardness assurance plan and MIL-PRF-38535.

TABLE IIA. Electrical test requirements.

Test requirements	Subgroups (in accordance with MIL-STD-883, method 5005, table I)	Subgroups (in accordance with MIL-PRF-38535, table III)	
	Device class M	Device class Q	Device class V
Interim electrical parameters (see 4.2)	1, 7, 9	1, 7, 9	1, 7, 9
Final electrical parameters (see 4.2)	1, 2, 3, 7, 8, 9, 10, 11 <u>1/</u>	1, 2, 3, 7, 8, 9, 10, 11 <u>1/</u>	1, 2, 3, 7, 8, 9, 10, 11 <u>2/ 3/</u>
Group A test requirements (see 4.4)	1, 2, 3, 4, 5, 6, 7, 8, 9, 10, 11	1, 2, 3, 4, 5, 6, 7, 8, 9, 10, 11	1, 2, 3, 4, 5, 6, 7, 8, 9, 10, 11
Group C end-point electrical parameters (see 4.4)	1, 2, 3, 7, 8, 9, 10, 11	1, 2, 3, 7, 8, 9, 10, 11	1, 2, 3, 7, 8, 9, 10, 11 <u>3/</u>
Group D end-point electrical parameters (see 4.4)	1, 7, 9	1, 7, 9	1, 7, 9
Group E end-point electrical parameters (see 4.4)	1, 7, 9	1, 7, 9	1, 7, 9

1/ PDA applies to subgroups 1 and 7.

2/ PDA applies to subgroups 1, 7, and delta's.

3/ Delta limits as specified in table IIB herein shall be required where specified, and the delta values shall be completed with reference to the zero hour electrical parameters.

TABLE IIB. Burn-in and operating life test, Delta parameters (+25°C).

Parameters	Symbol	Delta limits
Output voltage low	V _{OL}	±100 mV
Output voltage high	V _{OH}	±100 mV

STANDARD MICROCIRCUIT DRAWING DEFENSE SUPPLY CENTER COLUMBUS COLUMBUS, OHIO 43218-3990	SIZE A		5962-96548
		REVISION LEVEL C	SHEET 15

4.4.4.4 Single event phenomena (SEP). When specified in the purchase order or contract, SEP testing shall be performed on class V devices. SEP testing shall be performed on the Standard Evaluation Circuit (SEC) or alternate SEP test vehicle as approved by the qualifying activity at initial qualification and after any design or process changes which may affect the upset or latchup characteristics. Test four devices with zero failures. ASTM F1192 may be used as a guideline when performing SEP testing. The test conditions for SEP are as follows:

- a. The ion beam angle of incidence shall be between normal to the die surface and 60° to the normal, inclusive (i.e. $0^\circ \leq \text{angle} \leq 60^\circ$). No shadowing of the ion beam due to fixturing or package related effects is allowed.
- b. The fluence shall be ≥ 100 errors or $\geq 10^7$ ions/cm².
- c. The flux shall be between 10^2 and 10^5 ions/cm²/s. The cross-section shall be verified to be flux independent by measuring the cross-section at two flux rates which differ by at least an order of magnitude.
- d. The particle range shall be ≥ 20 microns in silicon.
- e. The upset test temperature shall be +25°C. The latchup test temperature shall be at the maximum rated operating temperature $\pm 10^\circ\text{C}$.
- f. Bias conditions shall be defined by the manufacturer for latchup measurements.
- g. For SEP test limits, see table IB herein.

TABLE III. Irradiation test connections.

Device type	Open	Ground	V _{DD} = 5.0 V \pm 0.5 V
01	5, 6	8	1, 2, 3, 4, 7, 9, 10, 11, 12, 13, 14, 15, 16

NOTE: Each pin except 8 and 16 will have a resistor of 2.49 k Ω \pm 5% for irradiation testing.

4.5 Methods of inspection. Methods of inspection shall be specified as follows:

4.5.1 Voltage and current. Unless otherwise specified, all voltages given are referenced to the microcircuit V_{SS} terminal. Currents given are conventional current and positive when flowing into the referenced terminal.

5. PACKAGING

5.1 Packaging requirements. The requirements for packaging shall be in accordance with MIL-PRF-38535 for device classes Q and V or MIL-PRF-38535, appendix A for device class M.

6. NOTES

6.1 Intended use. Microcircuits conforming to this drawing are intended for use for Government microcircuit applications (original equipment), design applications, and logistics purposes.

6.1.1 Replaceability. Microcircuits covered by this drawing will replace the same generic device covered by a contractor-prepared specification or drawing.

6.1.2 Substitutability. Device class Q devices will replace device class M devices.

STANDARD MICROCIRCUIT DRAWING DEFENSE SUPPLY CENTER COLUMBUS COLUMBUS, OHIO 43218-3990	SIZE A		5962-96548
		REVISION LEVEL C	SHEET 16

6.2 Configuration control of SMD's. All proposed changes to existing SMD's will be coordinated with the users of record for the individual documents. This coordination will be accomplished using DD Form 1692, Engineering Change Proposal.

6.3 Record of users. Military and industrial users should inform Defense Supply Center Columbus (DSCC) when a system application requires configuration control and which SMD's are applicable to that system. DSCC will maintain a record of users and this list will be used for coordination and distribution of changes to the drawings. Users of drawings covering microelectronic devices (FSC 5962) should contact DSCC-VA, telephone (614) 692-0544.

6.4 Comments. Comments on this drawing should be directed to DSCC-VA, Columbus, Ohio 43218-3990, or telephone (614) 692-0547.

6.5 Abbreviations, symbols, and definitions. The abbreviations, symbols, and definitions used herein are defined in MIL-PRF-38535 and MIL-HDBK-1331.

6.6 Sources of supply.

6.6.1 Sources of supply for device classes Q and V. Sources of supply for device classes Q and V are listed in QML-38535. The vendors listed in QML-38535 have submitted a certificate of compliance (see 3.6 herein) to DSCC-VA and have agreed to this drawing.

6.6.2 Approved sources of supply for device class M. Approved sources of supply for class M are listed in MIL-HDBK-103. The vendors listed in MIL-HDBK-103 have agreed to this drawing and a certificate of compliance (see 3.6 herein) has been submitted to and accepted by DSCC-VA.

6.7 Additional information. When specified in the purchase order or contract, a copy of the following additional data shall be supplied:

- a. RHA upset levels.
- b. Test conditions (SEP).
- c. Number of upsets (SEP).
- d. Number of transients (SEP).
- e. Occurrence of latchup (SEP).

STANDARD MICROCIRCUIT DRAWING DEFENSE SUPPLY CENTER COLUMBUS COLUMBUS, OHIO 43218-3990	SIZE A		5962-96548
		REVISION LEVEL C	SHEET 17

STANDARD MICROCIRCUIT DRAWING BULLETIN

DATE: 07-11-14

Approved sources of supply for SMD 5962-96548 are listed below for immediate acquisition information only and shall be added to MIL-HDBK-103 and QML-38535 during the next revision. MIL-HDBK-103 and QML-38535 will be revised to include the addition or deletion of sources. The vendors listed below have agreed to this drawing and a certificate of compliance has been submitted to and accepted by DSCC-VA. This information bulletin is superseded by the next dated revision of MIL-HDBK-103 and QML-38535. DSCC maintains an online database of all current sources of supply at <http://www.dscclia.mil/Programs/Smcr/>.

Standard microcircuit drawing PIN <u>1/</u>	Vendor CAGE number	Vendor similar PIN <u>2/</u>
5962H9654801QEA	65342	UT54ACS151PQAH
5962H9654801QEC	65342	UT54ACS151PQCH
5962H9654801QXA	65342	UT54ACS151UQAH
5962H9654801QXC	65342	UT54ACS151UQCH
5962H9654801VEA	65342	UT54ACS151PVAH
5962H9654801VEC	65342	UT54ACS151PVCH
5962H9654801VXA	65342	UT54ACS151UVAH
5962H9654801VXC	65342	UT54ACS151UVCH

1/ The lead finish shown for each PIN representing a hermetic package is the most readily available from the manufacturer listed for that part. If the desired lead finish is not listed contact the vendor to determine its availability.

2/ **Caution.** Do not use this number for item acquisition. Items acquired to this number may not satisfy the performance requirements of this drawing.

Vendor CAGE
number

65342

Vendor name
and address

Aeroflex Colorado Springs, Inc.
4350 Centennial Blvd.
Colorado Springs, CO 80907-3486

The information contained herein is disseminated for convenience only and the Government assumes no liability whatsoever for any inaccuracies in the information bulletin.