

SN54HC257, SN54HC258, SN74HC257, SN74HC258 QUAD 2-LINE TO 1-LINE DATA SELECTORS/MULTIPLEXERS WITH 3-STATE OUTPUTS

D2684, DECEMBER 1982--REVISED SEPTEMBER 1987

- High-Current 3-State Outputs Interface Directly with System Bus or Can Drive Up to 15 LSTTL Loads
- Provides Bus Interface from Multiple Sources in High Performance Systems
- Package Options Include Plastic "Small Outline" Packages, Ceramic Chip Carriers, and Standard Plastic and Ceramic 300-mil DIPs
- Dependable Texas Instruments Quality and Reliability

description

These devices are designed to multiplex signals from four-bit data sources to four-output data lines in bus-organized systems. The 3-state outputs will not load the data lines when the output control pin (\bar{G}) is at a high-logic level.

The SN54HC257 and SN54HC258 are characterized for operation over the full military temperature range of -55°C to 125°C . The SN74HC257 and SN74HC258 are characterized for operation from -40°C to 85°C .

FUNCTION TABLE

OUTPUT CONTROL \bar{G}	INPUTS		OUTPUT Y		
	SELECT \bar{A}/\bar{B}	DATA		'HC257	'HC258
		A	B		
H	X	X	X	Z	Z
L	L	L	X	L	H
L	L	H	X	H	L
L	H	X	L	L	H
L	H	X	H	H	L

SN54HC257, SN54HC258 . . . J PACKAGE
SN74HC257, SN74HC258 . . . D/DW† OR N PACKAGE
(TOP VIEW)

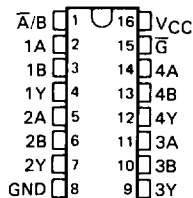

†Contact the factory for D or DW availability.

SN54HC257, SN54HC258 . . . FK PACKAGE
(TOP VIEW)

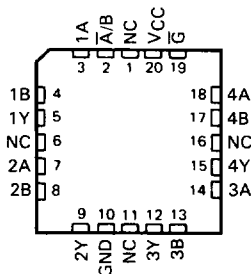

NC—No internal connection

2

HCMOS Devices

SN54HC257, SN54HC258, SN74HC257, SN74HC258
QUAD 2-LINE TO 1-LINE DATA SELECTORS/MULTIPLEXERS
WITH 3-STATE OUTPUTS

logic symbols†

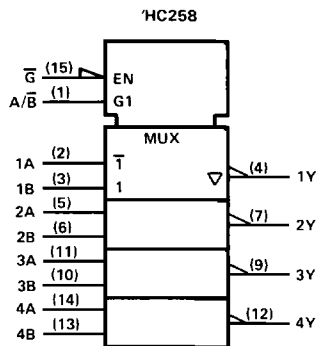
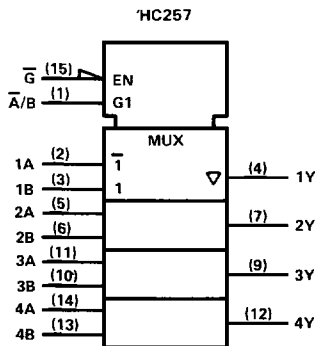

†These symbols are in accordance with ANSI/IEEE Std 91-1984 and IEC Publication 617-12.

logic diagrams (positive logic)

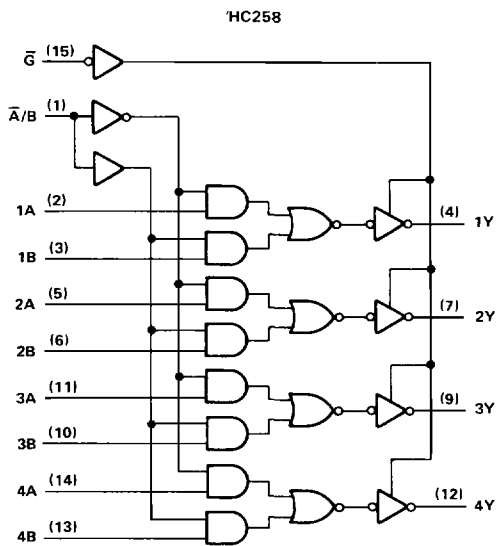
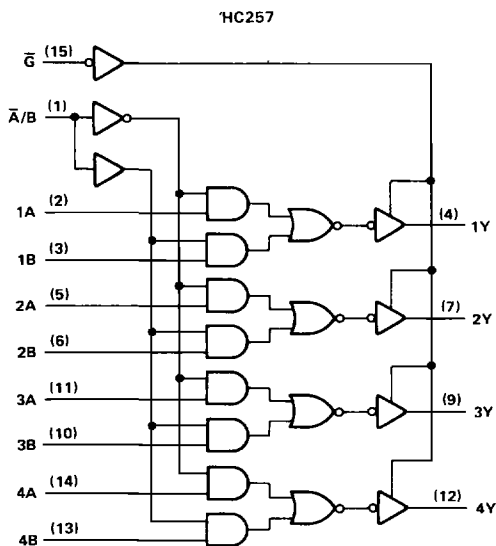

Pin numbers shown are for D/DW, J, and N packages.

2

HC MOS Devices

**SN54HC257, SN54HC258, SN74HC257, SN74HC258
QUAD 2-LINE TO 1-LINE DATA SELECTORS/MULTIPLEXERS
WITH 3-STATE OUTPUTS**

absolute maximum ratings over operating free-air temperature range†

Supply voltage, V_{CC}	-0.5 V to 7 V
Input clamp current, I_{IK} ($V_I < 0$ or $V_I > V_{CC}$)	± 20 mA
Output clamp current, I_{OK} ($V_O < 0$ or $V_O > V_{CC}$)	± 20 mA
Continuous output current, I_O ($V_O = 0$ to V_{CC})	± 35 mA
Continuous current through V_{CC} or GND pins	± 70 mA
Lead temperature 1,6 mm (1/16 in) from case for 60 s: FK or J package	300°C
Lead temperature 1,6 mm (1/16 in) from case for 10 s: D, DW, or N package	260°C
Storage temperature range	-65°C to 150°C

† Stresses beyond those listed under "absolute maximum ratings" may cause permanent damage to the device. These are stress ratings only, and functional operation of the device at these or any other conditions beyond those indicated under "recommended operating conditions" is not implied. Exposure to absolute-maximum-rated conditions for extended periods may affect device reliability.

recommended operating conditions

		SN54HC257 SN54HC258			SN74HC257 SN74HC258			UNIT
		MIN	NOM	MAX	MIN	NOM	MAX	
V_{CC}	Supply voltage	2	5	6	2	5	6	V
V_{IH}	High-level input voltage	$V_{CC} = 2$ V	1.5		1.5			V
		$V_{CC} = 4.5$ V	3.15		3.15			
		$V_{CC} = 6$ V	4.2		4.2			
V_{IL}	Low-level input voltage	$V_{CC} = 2$ V	0	0.3	0	0.3	V	
		$V_{CC} = 4.5$ V	0	0.9	0	0.9		
		$V_{CC} = 6$ V	0	1.2	0	1.2		
V_I	Input voltage	0	V_{CC}	0	V_{CC}	V		
V_O	Output voltage	0	V_{CC}	0	V_{CC}	V		
t_t	Input transition (rise and fall) times	$V_{CC} = 2$ V	0	1000	0	1000	ns	
		$V_{CC} = 4.5$ V	0	500	0	500		
		$V_{CC} = 6$ V	0	400	0	400		
T_A	Operating free-air temperature	-55	125	-40	85	°C		

electrical characteristics over recommended operating free-air temperature range (unless otherwise noted)

PARAMETER	TEST CONDITIONS	V_{CC}	$T_A = 25^\circ\text{C}$		SN54HC257 SN54HC258		SN74HC257 SN74HC258		UNIT
			MIN	TYP	MAX	MIN	MAX	MIN	
V_{OH}	$V_I = V_{IH}$ or V_{IL} , $I_{OH} = -20$ μA	2 V	1.9	1.998	1.9	1.9	V		
		4.5 V	4.4	4.499	4.4	4.4			
		6 V	5.9	5.999	5.9	5.9			
	4.5 V	3.98	4.30	3.7	3.84				
	$V_I = V_{IH}$ or V_{IL} , $I_{OH} = -7.8$ mA	6 V	5.48	5.80	5.2	5.34			
V_{OL}	$V_I = V_{IH}$ or V_{IL} , $I_{OL} = 20$ μA	2 V	0.002	0.1	0.1	0.1	V		
		4.5 V	0.001	0.1	0.1	0.1			
		6 V	0.001	0.1	0.1	0.1			
	$V_I = V_{IH}$ or V_{IL} , $I_{OL} = 6$ mA	4.5 V	0.17	0.26	0.4	0.33			
	$V_I = V_{IH}$ or V_{IL} , $I_{OL} = 7.8$ mA	6 V	0.15	0.26	0.4	0.33			
I_I	$V_I = V_{CC}$ or 0	6 V	± 0.1	± 100	± 1000	± 1000	nA		
I_{OZ}	$V_O = V_{CC}$ or 0, $V_I = V_{IH}$ or V_{IL}	6 V	± 0.01	± 0.5	± 10	± 5	μA		
I_{CC}	$V_I = V_{CC}$ or 0, $I_O = 0$	6 V		8	160	80	μA		
C_i		2 to 6 V	3	10	10	10	pF		

2
HC MOS Devices

SN54HC257, SN74HC257
QUAD 2-LINE TO 1-LINE DATA SELECTORS/MULTIPLEXERS
WITH 3-STATE OUTPUTS

switching characteristics over recommended operating free-air temperature range (unless otherwise noted), $C_L = 50$ pF (see Note 1)

PARAMETER	FROM (INPUT)	TO (OUTPUT)	V _{CC}	T _A = 25°C			SN54HC257		SN74HC257		UNIT
				MIN	TYP	MAX	MIN	MAX	MIN	MAX	
t _{pd}	A or B	Any Y	2 V		50	100		150		125	ns
			4.5 V		10	20		30		25	
			6 V		9	17		25		21	
t _{pd}	\bar{A}/B	Any Y	2 V		50	100		150		125	ns
			4.5 V		10	20		30		25	
			6 V		9	17		25		21	
t _{en}	\bar{G}	Any Y	2 V		75	150		225		190	ns
			4.5 V		15	30		45		38	
			6 V		13	26		38		32	
t _{dis}	\bar{G}	Any Y	2 V		75	150		225		190	ns
			4.5 V		15	30		45		38	
			6 V		13	26		38		32	
t _t		Any	2 V		28	60		90		75	ns
			4.5 V		8	12		18		15	
			6 V		6	10		15		13	

C _{pd}	Power dissipation capacitance per multiplexer	No load, T _A = 25°C	40 pF typ
-----------------	---	--------------------------------	-----------

switching characteristics over recommended operating free-air temperature range (unless otherwise noted), $C_L = 150$ pF (see Note 1)

PARAMETER	FROM (INPUT)	TO (OUTPUT)	V _{CC}	T _A = 25°C			SN54HC257		SN74HC257		UNIT
				MIN	TYP	MAX	MIN	MAX	MIN	MAX	
t _{pd}	A or B	Any Y	2 V		75	150		245		190	ns
			4.5 V		15	30		45		38	
			6 V		13	26		38		32	
t _{pd}	\bar{A}/B	Any Y	2 V		75	150		245		190	ns
			4.5 V		15	30		45		38	
			6 V		13	26		38		32	
t _{en}	\bar{G}	Any Y	2 V		100	200		300		250	ns
			4.5 V		24	40		60		50	
			6 V		18	34		51		43	
t _t		Any	2 V		45	210		315		265	ns
			4.5 V		17	42		63		53	
			6 V		13	36		53		45	

NOTE 1: Load circuits and voltage waveforms are shown in Section 1.

SN54HC258, SN74HC258
QUAD 2-LINE TO 1-LINE DATA SELECTORS/MULTIPLEXERS
WITH 3-STATE OUTPUTS

switching characteristics over recommended operating free-air temperature range (unless otherwise noted), $C_L = 50$ pF (see Note 1)

PARAMETER	FROM (INPUT)	TO (OUTPUT)	V _{CC}	T _A = 25°C			SN54HC258		SN74HC258		UNIT
				MIN	TYP	MAX	MIN	MAX	MIN	MAX	
t _{pd}	A or B	Any Y	2 V		60	100		150		125	ns
			4.5 V		13	20		30		25	
			6 V		12	17		25		21	
t _{pd}	\bar{A}/B	Any Y	2 V		60	115		175		145	ns
			4.5 V		13	23		35		29	
			6 V		12	20		30		25	
t _{en}	\bar{G}	Any Y	2 V		70	150		225		190	ns
			4.5 V		15	30		45		38	
			6 V		13	26		38		32	
t _{dis}	\bar{G}	Any Y	2 V		75	150		225		190	ns
			4.5 V		15	30		45		38	
			6 V		13	26		38		32	
t _t		Any	2 V		28	60		90		75	ns
			4.5 V		8	12		18		15	
			6 V		6	10		15		13	

C _{pd}	Power dissipation capacitance per multiplexer	No load, T _A = 25°C	40 pF typ
-----------------	---	--------------------------------	-----------

switching characteristics over recommended operating free-air temperature range (unless otherwise noted), $C_L = 150$ pF (see Note 1)

PARAMETER	FROM (INPUT)	TO (OUTPUT)	V _{CC}	T _A = 25°C			SN54HC258		SN74HC258		UNIT
				MIN	TYP	MAX	MIN	MAX	MIN	MAX	
t _{pd}	A or B	Any Y	2 V		95	150		245		190	ns
			4.5 V		23	30		45		38	
			6 V		21	26		38		32	
t _{pd}	\bar{A}/B	Any Y	2 V		95	165		240		210	ns
			4.5 V		23	33		48		42	
			6 V		21	28		41		36	
t _{en}	\bar{G}	Any Y	2 V		100	200		300		250	ns
			4.5 V		24	40		60		50	
			6 V		18	34		51		43	
t _t		Any	2 V		45	210		315		265	ns
			4.5 V		17	42		63		53	
			6 V		13	36		53		45	

NOTE 1: Load circuits and voltage waveforms are shown in Section 1.

2
HCMOS Devices