

54LS42/DM54LS42/DM74LS42 BCD/Decimal Decoders

General Description

These BCD-to-decimal decoders consist of eight inverters and ten, four-input NAND gates. The inverters are connected in pairs to make BCD input data available for decoding by the NAND gates. Full decoding of input logic ensures that all outputs remain off for all invalid (10–15) input conditions.

Features

- Diode clamped inputs
- Also for applications as 4-line-to-16-line decoders; 3-line-to-8-line decoders
- All outputs are high for invalid input conditions
- Alternate Military/Aerospace device (54LS42) is available. Contact a National Semiconductor Sales Office/Distributor for specifications.

Connection Diagram

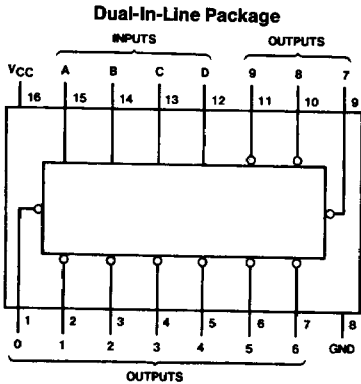

TL/F/6365-1

Order Number 54LS42DMQB, 54LS42FMQB,
DM54LS42J, DM54LS42W, DM74LS42M or DM74LS42N
See NS Package Number J16A, M16A, N16E or W16A

Function Table

No.	BCD Inputs				Decimal Outputs										
	D	C	B	A	0	1	2	3	4	5	6	7	8	9	
0	L	L	L	L	L	H	H	H	H	H	H	H	H	H	H
1	L	L	L	H	H	L	H	H	H	H	H	H	H	H	H
2	L	L	H	L	H	H	L	H	H	H	H	H	H	H	H
3	L	L	H	H	H	H	H	L	H	H	H	H	H	H	H
4	L	H	L	L	H	H	H	H	L	H	H	H	H	H	H
5	L	H	L	H	H	H	H	H	H	L	H	H	H	H	H
6	L	H	H	L	H	H	H	H	H	H	L	H	H	H	H
7	L	H	H	H	H	H	H	H	H	H	H	L	H	H	H
8	H	L	L	L	H	H	H	H	H	H	H	H	L	H	H
9	H	L	L	H	H	H	H	H	H	H	H	H	H	L	L
I N V A L I D	H	L	H	L	H	H	H	H	H	H	H	H	H	H	H
	H	L	H	H	H	H	H	H	H	H	H	H	H	H	H
	H	H	L	L	H	H	H	H	H	H	H	H	H	H	H
	H	H	L	H	H	H	H	H	H	H	H	H	H	H	H
	H	H	H	L	H	H	H	H	H	H	H	H	H	H	H
	H	H	H	H	H	H	H	H	H	H	H	H	H	H	H

H = High Level
L = Low Level

Logic Diagram

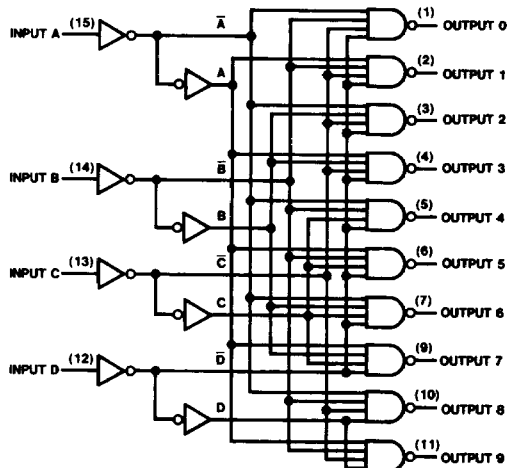

TL/F/6365-2

Absolute Maximum Ratings (Note)

If Military/Aerospace specified devices are required, please contact the National Semiconductor Sales Office/Distributors for availability and specifications.

Supply Voltage	7V
Input Voltage	7V
Operating Free Air Temperature Range	
DM54LS and 54LS	-55°C to +125°C
DM74LS	0°C to +70°C
Storage Temperature Range	-65°C to +150°C

Note: The "Absolute Maximum Ratings" are those values beyond which the safety of the device cannot be guaranteed. The device should not be operated at these limits. The parametric values defined in the "Electrical Characteristics" table are not guaranteed at the absolute maximum ratings. The "Recommended Operating Conditions" table will define the conditions for actual device operation.

Recommended Operating Conditions

Symbol	Parameter	DM54LS42			DM74LS42			Units
		Min	Nom	Max	Min	Nom	Max	
V _{CC}	Supply Voltage	4.5	5	5.5	4.75	5	5.25	V
V _{IH}	High Level Input Voltage	2			2			V
V _{IL}	Low Level Input Voltage			0.7			0.8	V
I _{OH}	High Level Output Current			-0.4			-0.4	mA
I _{OL}	Low Level Output Current			4			8	mA
T _A	Free Air Operating Temperature	-55		125	0		70	°C

Electrical Characteristics over recommended operating free air temperature range (unless otherwise noted)

Symbol	Parameter	Conditions	Min	Typ (Note 1)	Max	Units	
V _I	Input Clamp Voltage	V _{CC} = Min, I _I = -18 mA			-1.5	V	
V _{OH}	High Level Output Voltage	V _{CC} = Min, I _{OH} = Max V _{IL} = Max, V _{IH} = Min	DM54	2.5	3.4	V	
			DM74	2.7	3.4		
V _{OL}	Low Level Output Voltage	V _{CC} = Min, I _{OL} = Max V _{IL} = Max, V _{IH} = Min	DM54		0.25	0.4	V
			DM74		0.35	0.5	
		I _{OL} = 4 mA, V _{CC} = Min	DM74		0.25	0.4	
I _I	Input Current @ Max Input Voltage	V _{CC} = Max, V _I = 7V			0.1	mA	
I _{IH}	High Level Input Current	V _{CC} = Max, V _I = 2.7V			20	μA	
I _{IL}	Low Level Input Current	V _{CC} = Max, V _I = 0.4V			-0.4	mA	
I _{OS}	Short Circuit Output Current	V _{CC} = Max (Note 2)	DM54	-20	-100	mA	
			DM74	-20	-100		
I _{CC}	Supply Current	V _{CC} = Max (Note 3)		7	13	mA	

Note 1: All typicals are at V_{CC} = 5V, T_A = 25°C.

Note 2: Not more than one output should be shorted at a time, and the duration should not exceed one second.

Note 3: I_{CC} is measured with all outputs open and all inputs grounded.

Switching Characteristics at $V_{CC} = 5V$ and $T_A = 25^{\circ}C$ (See Section 1 for Test Waveforms and Output Load)

Symbol	Parameter	From (Input) To (Output)	$R_L = 2\ k\Omega$				Units
			$C_L = 15\ pF$		$C_L = 50\ pF$		
			Min	Max	Min	Max	
t_{PHL}	Propagation Delay Time High to Low Level Output	A, B, C, or D (2 Levels of Logic) to Output		25		30	ns
t_{PHL}	Propagation Delay Time High to Low Level Output	A, B, C, or D (3 Levels of Logic) to Output		30		35	ns
t_{PLH}	Propagation Delay Time Low to High Level Output	A, B, C, or D (2 Levels of Logic) to Output		25		30	ns
t_{PLH}	Propagation Delay Time Low to High Level Output	A, B, C, or D (3 Levels of Logic) to Output		30		35	ns