



TS2937

500mA Ultra Low Dropout Fixed Positive Voltage Regulator

TO-220



TO-263



TO-252



SOT-223



Pin assignment:
 1. Input
 2. Ground
 3. Output

Low Dropout Voltage 0.6V max.

General Description

The TS2937 series of fixed-voltage monolithic micro-power voltage regulators is designed for a wide range of applications. This device excellent choice of use in battery-power application. Furthermore, the quiescent current increases on slightly at dropout, which prolongs battery life.

This series of fixed-voltage regulators features very low ground current (100uA Typ.) and very low drop output voltage (Typ. 60mV at light load and 600mV at 500mA). This includes a tight initial tolerance of 1% typ., extremely good line regulation of 0.05% typ., and very low output temperature coefficient.

This series is offered in 3-pin TO-263, TO-220, TO-252 & SOT-223 package.

Features

- ◇ Dropout voltage typically 0.6V @Io=500mA
- ◇ Output current up to 500mA
- ◇ Output voltage trimmed before assembly
- ◇ -18V Reverse peak voltage
- ◇ +30V Input over voltage protection
- ◇ +60V Transient peak voltage
- ◇ Internal current limit
- ◇ Thermal shutdown protection

Block Diagram

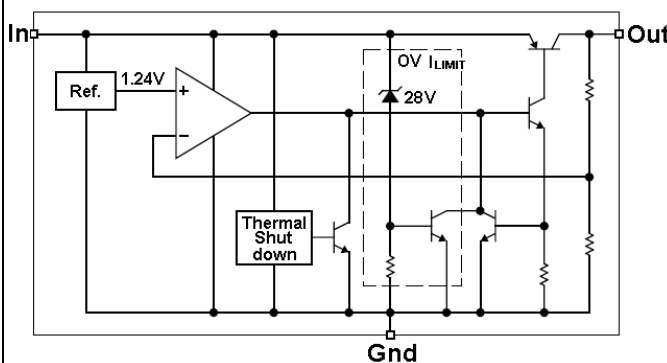

Ordering Information

Part No.	Operation Temp.	Package
TS2937CZxx	-40 ~ +125 °C	TO-220
TS2937CMxx		TO-263
TS2937CPxx		TO-252
TS2937CWxx		SOT-223

Note: Where **xx** denotes voltage option, available are 12V, 5.0V, 3.3V, 2.5V and 1.8V. Contact factory for additional voltage options.

Absolute Maximum Rating (Note 1)

Input Supply Voltage (Note 2)	V _{in}	-18 ~ +60	V
Operation Input Supply Voltage	V _{in (operate)}	26	V
Power Dissipation (Note 3)	P _D	Internally Limited	W
Operating Junction Temperature Range	T _J	-40 ~ +125	°C
Storage Temperature Range	T _{STG}	-65 ~ +150	°C
Lead Soldering Temperature (260 °C)			
TO-220 / TO-263 Package		5	S
TO-252 / SOT-223 Package		4	



Electrical Characteristics					
Vin = Vout + 1V, IL = 5mA, Co = 10uF, Ta = 25 °C, unless otherwise specified.					
Parameter	Conditions	Min	Typ	Max	Unit
Output Voltage		0.980 Vo	5.0 / 3.3 2.5 / 1.8	1.020 Vo	V
Output Voltage	5mA ≤ IL ≤ 500mA, Vo+1V ≤ Vin ≤ 26V	0.970 Vo		1.030 Vo	V
Input Supply Voltage		--	--	26	V
Output Voltage Temperature Coefficient		--	50	150	ppm/°C
Line Regulation	Vo+1V ≤ Vin ≤ 26V	--	0.05	0.5	%
Load Regulation	5mA ≤ IL ≤ 500mA	--	0.2	1.0	%
Dropout Voltage (Note 4)	IL=100mA	--	100	300	mV
	IL=300mA	--	400	500	
	IL=500mA	--	600	700	
Quiescent Current (Note 5)	IL=100uA	--	100	--	uA
	IL=300mA	--	12	--	mA
	IL=500mA	--	25	--	mA
Short Circuit Current (Note 6)	Vout=0	--	--	1.3	A
Output Noise, 10Hz to 100KHz, IL=10mA	CL=2.2uF	--	500	--	uVrms
	CL=3.3uF	--	350	--	
	CL=33uF	--	120	--	

Thermal Performance			
Condition	Package type	Typ	Unit
Thermal Resistance Junction to Ambient	TO-220	60	°C/W
	TO-263	80	
	TO-252	150	
	SOT-223	170	

Note 1: Absolute Maximum Rating is limits beyond which damage to the device may occur. For guaranteed Specifications and test conditions see the Electrical Characteristics.

Note 2: Maximum positive supply voltage of 60V must be limited duration (<100mS) and duty cycle (<1%).

Note 3: The maximum allowable power dissipation is a function of the maximum junction temperature, Tj, the junction to ambient thermal resistance, θja, and the ambient temperature, Ta. Exceeding the maximum allowable power dissipation will cause excessive die temperature, and the regulator will go into thermal shutdown. The effective value of θja can be reduced by using a heatsink.

Note 4: Dropout voltage is defined as the input to output differential at which the output voltage drops 2% below its nominal value measured at 1V differential.

Note 5: Ground pin current is the regulator quiescent current. The total current drawn from the source is the sum of the ground pin current and output load current.

Note 6: Output current will decrease with increasing temperature, but it will be not dropped below 500mA at the maximum specified temperature.

Application Information

The TS2937 series is a high performance with low dropout voltage regulator suitable for moderate to high current and voltage regulator application. Its 600mV(typ) dropout voltage at full load and over temperature makes it especially valuable in battery power systems and as high efficiency noise filters in post regulator applications. Unlike normal NPN transistor design, where the base to emitter voltage drop and collector to emitter saturation voltage limit the minimum dropout voltage, dropout performance of the PNP output of these devices is limited only by low Vce saturation voltage.

The TS2937 series is fully protected from damage due to fault conditions. Linear current limiting is provided. Output current during overload conditions is constant. Thermal shutdown the device when the die temperature exceeds the maximum safe operating temperature. Transient protection allows device survival even when the input voltage spikes above and below nominal. The output structure of these regulators allows voltages in excess of the desired output voltage to be applied without reverse current flow.

Typical Application Circuit

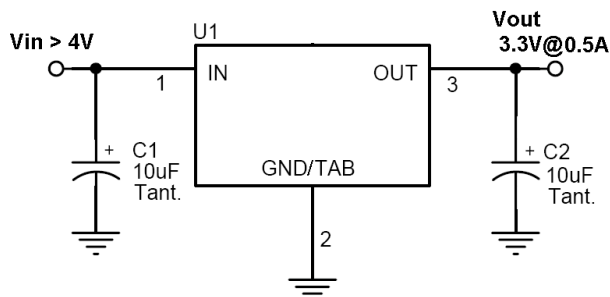

Output Capacitor

The TS2937 series requires an output capacitor to maintain stability and improve transient response. Proper capacitor selection is important to ensure proper operation. The output capacitor selection is dependent upon the ESR of the output capacitor the maintain stability. When the output capacitor is 10uF or greater, the output capacitor should have an ESR less than 2 ohm. This will improve transient response as well as promoted stability. Ultra low ESR capacitors (<100mohm), such as ceramic chip capacitors may promote instability. These very low ESR levels may cause an oscillation and/or under damped transient response. A low ESR solid tantalum capacitor works extremely well and provides good transient response and stability over

temperature. Aluminum electrolytic can also be used, as long as the ESR of the capacitor is <2ohm. The value of the output capacitor can be increased without limit. Higher capacitance values help to improved transient response and ripple rejection and reduce output noise.

Minimum Load Current

The TS2937 series is specified between finite loads. If the output current is too small leakage currents dominate and the output voltage rises. A 1mA minimum load current is necessary for proper regulation.

Input Capacitor

An input capacitor of 1uF or greater is recommended when the device is more that 4 inches away from the bulk AC supply capacitance or when the supply is a battery. Small and surface mount ceramic chip capacitors can be used for bypassing. Larger values will help to improve ripple rejection by bypassing the input to the regulator, further improving the integrity of the output voltage.

Thermal Characteristics

A heatsink may be required depending on the maximum power dissipation and maximum ambient temperature of the application. Under all possible operating conditions, the junction temperature must be within the range specified under absolute maximum ratings. To determine if the heatsink is required, the power dissipated by the regulator, P_D must be calculated.

The below formula shows the voltages and currents for calculating the P_D in the regulator:

$$I_{in} = I_L / I_G$$

$$P_D = (V_{in} - V_{out}) * I_L + (V_{in}) * I_G$$

$$\text{Ex. } P_D = (3.3V - 2.5V) * 0.5A + 3.3V * 11mA$$

$$= 400mW + 36mW$$

$$= 436mW$$

Remark: I_L is output load current,

I_G is ground current.

V_{in} is input voltage

V_{out} is output voltage

The next parameter which must be calculated is the maximum allowable temperature rise.



Application Information (continued)

$T_R(\text{max})$ is calculated by the using to formula:

$$T_R(\text{max}) = T_J(\text{max}) - T_A(\text{max})$$

Where: $T_J(\text{max})$ is the maximum allowable junction temperature, which is 125 °C for commercial grade parts. $T_A(\text{max})$ is the maximum ambient temperature which will be encountered in the application.

Using the calculated values for $T_R(\text{max})$ and P_D , the maximum allowable value for the junction to ambient thermal resistance, θ_{ja} , can now be found:

$$\theta_{ja} = T_R(\text{max}) / P_D$$

IMPORTANT: if the maximum allowable value for is found to be ≥ 60 °C/W for the TO-220 package, ≥ 80 °C/W for the TO-263 package, ≥ 150 °C/W for the TO-252 package, or ≥ 170 °C/W for the SOT-223 package, no heatsink is needed since the package alone will dissipate enough heat to satisfy these requirements. If the calculated value for θ_{ja} falls below these limits, a heatsink is required.

TO-220 Mechanical Drawing

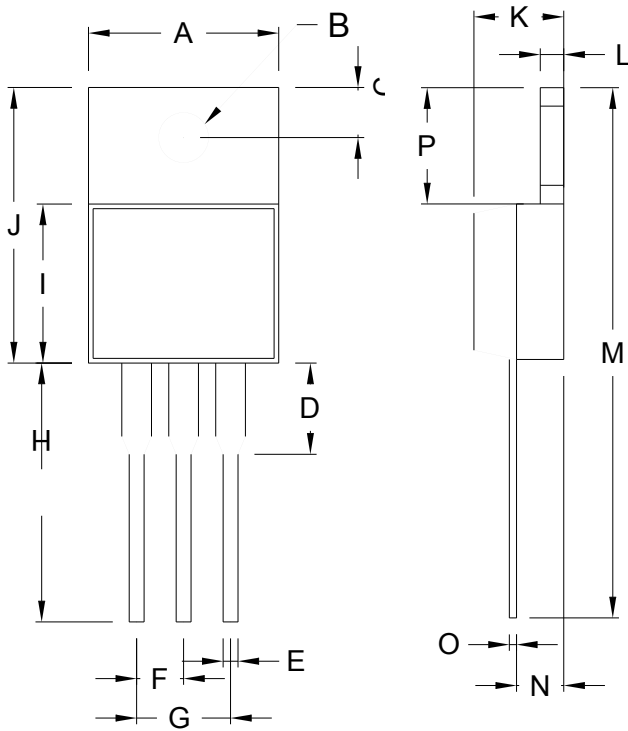

TO-220 DIMENSION				
DIM	MILLIMETERS		INCHES	
	MIN	MAX	MIN	MAX
A	10.000	10.500	0.394	0.413
B	3.240	4.440	0.128	0.175
C	2.440	2.940	0.096	0.116
D	-	6.350	-	0.250
E	0.381	1.106	0.015	0.040
F	2.345	2.715	0.092	0.058
G	4.690	5.430	0.092	0.107
H	12.700	14.732	0.500	0.581
I	8.382	9.017	0.330	0.355
J	14.224	16.510	0.560	0.650
K	3.556	4.826	0.140	0.190
L	0.508	1.397	0.020	0.055
M	27.700	29.620	1.060	1.230
N	2.032	2.921	0.080	0.115
O	0.255	0.610	0.010	0.024
P	5.842	6.858	0.230	0.270

TO-263 Mechanical Drawing

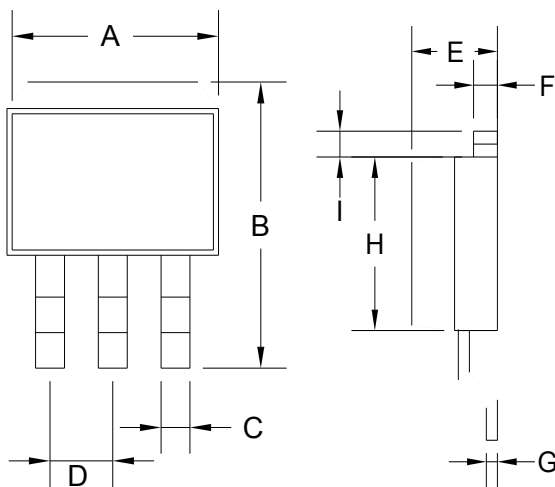

TO-263 DIMENSION				
DIM	MILLIMETERS		INCHES	
	MIN	MAX	MIN	MAX
A	10.000	10.500	0.394	0.413
B	14.605	15.875	0.575	0.625
C	0.508	0.991	0.020	0.039
D	2.420	2.660	0.095	0.105
E	4.064	4.830	0.160	0.190
F	1.118	1.400	0.045	0.055
G	0.450	0.730	0.018	0.029
H	8.280	8.800	0.325	0.346
I	1.140	1.400	0.044	0.055
J	1.480	1.520	0.058	0.060

TO-252 Mechanical Drawing

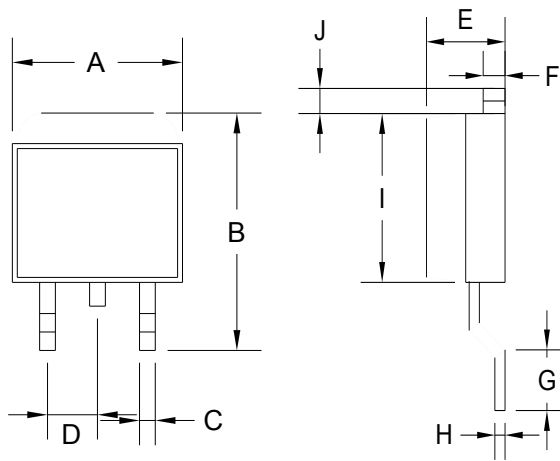

TO-252 DIMENSION				
DIM	MILLIMETERS		INCHES	
	MIN	MAX	MIN	MAX
A	6.570	6.840	0.259	0.269
B	9.250	10.400	0.364	0.409
C	0.550	0.700	0.022	0.028
D	2.560	2.670	0.101	0.105
E	2.300	2.390	0.090	0.094
F	0.490	0.570	0.019	0.022
G	1.460	1.580	0.057	0.062
H	0.520	0.570	0.020	0.022
I	5.340	5.550	0.210	0.219
J	1.460	1.640	0.057	0.065

SOT-223 Mechanical Drawing

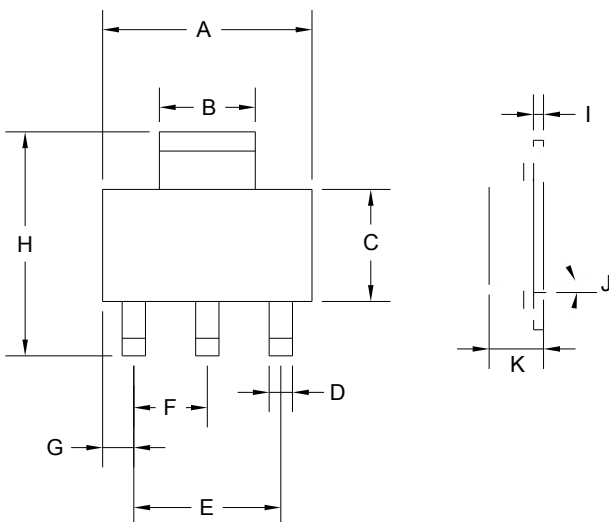

SOT-223 DIMENSION				
DIM	MILLIMETERS		INCHES	
	MIN	MAX	MIN	MAX
A	6.350	6.850	0.250	0.270
B	2.900	3.100	0.114	0.122
C	3.450	3.750	0.136	0.148
D	0.595	0.635	0.023	0.025
E	4.550	4.650	0.179	0.183
F	2.250	2.350	0.088	0.093
G	0.835	1.035	0.032	0.041
H	6.700	7.300	0.263	0.287
I	0.250	0.355	0.010	0.014
J	10°	16°	10°	16°
K	1.550	1.800	0.061	0.071