

OCTAL D-TYPE TRANSPARENT LATCH; 3-STATE; INVERTING

FEATURES

- 3-state inverting outputs for bus oriented applications
- Common 3-state output enable input
- Output capability: bus driver
- I_{CC} category: MSI

GENERAL DESCRIPTION

The 74HC/HCT533 are high-speed Si-gate CMOS devices and are pin compatible with low power Schottky TTL (LSSTTL). They are specified in compliance with JEDEC standard no. 7A.

The 74HC/HCT533 are octal D-type transparent latches featuring separate D-type inputs for each latch and 3-state outputs for bus oriented applications. A latch enable (LE) input and an output enable (\overline{OE}) input are common to all latches.

The "533" consists of eight D-type transparent latches with 3-state inverting outputs. When LE is HIGH, data at the D_n inputs enter the latches. In this condition the latches are transparent, i.e. a latch output will change state each time its corresponding D-input changes.

When LE is LOW the latches store the information that was present at the D-inputs a set-up time preceding the HIGH-to-LOW transition of LE.

When \overline{OE} is LOW, the contents of the 8 latches are available at the outputs. When \overline{OE} is HIGH, the outputs go to the high impedance OFF-state. Operation of the \overline{OE} input does not affect the state of the latches.

The "533" is functionally identical to the "373", "563" and "573", but the "373" and "573" have non-inverted outputs and the "563" and "573" have a different pin arrangement.

SYMBOL	PARAMETER	CONDITIONS	TYPICAL		UNIT
			HC	HCT	
t _{PHL} / t _{PLH}	propagation delay D _n to \overline{Q}_n LE to \overline{Q}_n	C _L = 15 pF V _{CC} = 5 V	14 18	16 19	ns ns
C _I	input capacitance		3.5	3.5	pF
CPD	power dissipation capacitance per latch	notes 1 and 2	34	34	pF

GND = 0 V; T_{amb} = 25 °C; t_r = t_f = 6 ns

Notes

- CPD is used to determine the dynamic power dissipation (P_D in μW):
 $P_D = CPD \times V_{CC}^2 \times f_i + \sum (C_L \times V_{CC}^2 \times f_o)$ where:
 f_i = input frequency in MHz C_L = output load capacitance in pF
 f_o = output frequency in MHz V_{CC} = supply voltage in V
 $\sum (C_L \times V_{CC}^2 \times f_o)$ = sum of outputs
- For HC the condition is V_I = GND to V_{CC}
 For HCT the condition is V_I = GND to V_{CC} - 1.5 V

PACKAGE OUTLINES

SEE PACKAGE INFORMATION SECTION

PIN DESCRIPTION

PIN NO.	SYMBOL	NAME AND FUNCTION
1	\overline{OE}	3-state output enable input (active LOW)
2, 5, 6, 9, 12, 15, 16, 19	\overline{Q}_0 to \overline{Q}_7	3-state latch outputs
3, 4, 7, 8, 13, 14, 17, 18	D ₀ to D ₇	data inputs
10	GND	ground (0 V)
11	LE	latch enable input (active HIGH)
20	V _{CC}	positive supply voltage

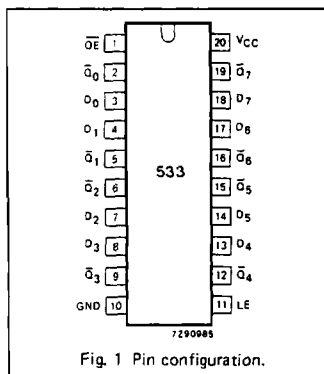

Fig. 1 Pin configuration.

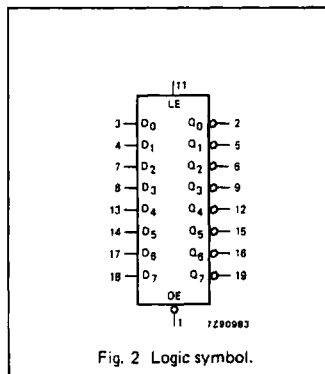

Fig. 2 Logic symbol.

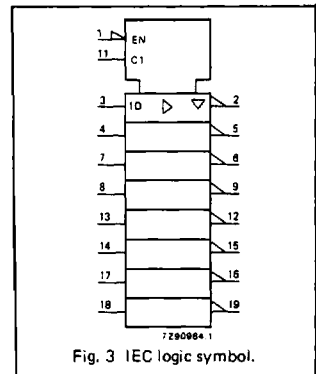
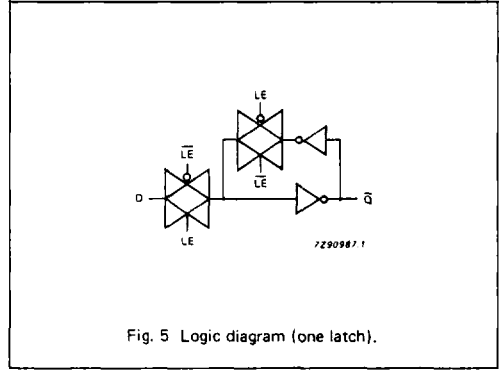
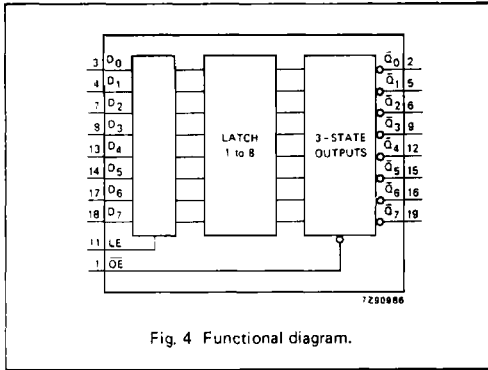

Fig. 3 IEC logic symbol.



FUNCTION TABLE

OPERATING MODES	INPUTS			INTERNAL LATCHES	OUTPUTS \bar{Q}_0 to \bar{Q}_7
	\bar{OE}	LE	D_n		
enable and read register (transparent mode)	L L	H H	L L	L H	H L
latch and read register	L L	L L	l h	L H	H L
latch register and disable outputs	H H	X X	X X	X X	Z Z

H = HIGH voltage level
h = HIGH voltage level one set-up prior to the HIGH-to-LOW LE transition
L = LOW voltage level
l = LOW voltage level one set-up prior to the HIGH-to-LOW LE transition
X = don't care
Z = high impedance OFF-state

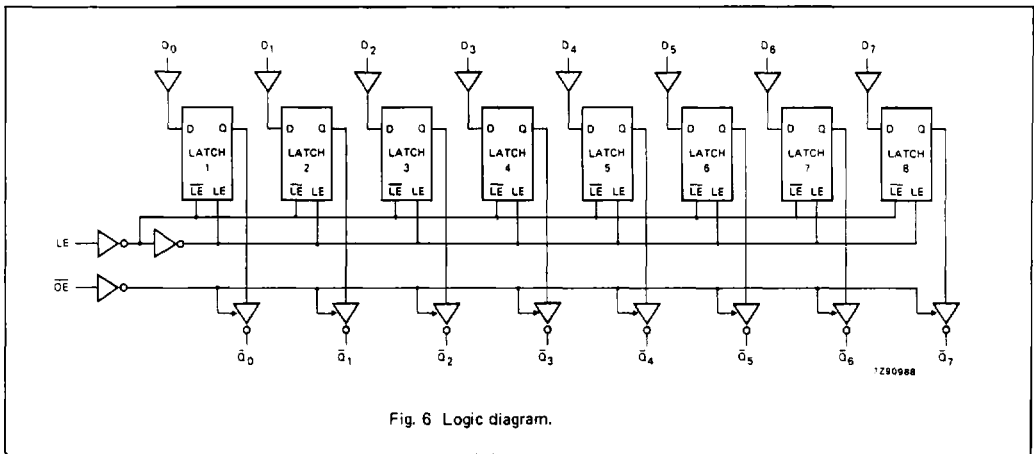

DC CHARACTERISTICS FOR 74HC

For the DC characteristics see chapter "HCMOS family characteristics", section "Family specifications".

Output capability: bus driver

I_{CC} category: MSI

AC CHARACTERISTICS FOR 74HC

GND = 0 V; t_r = t_f = 6 ns; C_L = 50 pF

SYMBOL	PARAMETER	T _{amb} (°C)						UNIT	TEST CONDITIONS		
		74HC							V _{CC} V	WAVEFORMS	
		+25			-40 to +85		-40 to +125				
		min.	typ.	max.	min.	max.	min.				max.
t _{PHL} / t _{PLH}	propagation delay D _n to \bar{Q}_n		47 17 14	150 30 26		190 38 33		225 45 38	ns	2.0 4.5 6.0	Fig. 7
t _{PHL} / t _{PLH}	propagation delay LE to \bar{Q}_n		58 21 17	175 35 30		220 44 37		265 53 45	ns	2.0 4.5 6.0	Fig. 8
t _{PZH} / t _{PZL}	3-state output enable time \bar{OE} to \bar{Q}_n		44 16 13	150 30 26		190 38 33		225 45 38	ns	2.0 4.5 6.0	Fig. 9
t _{PHZ} / t _{PLZ}	3-state output disable time \bar{OE} to \bar{Q}_n		50 18 14	150 30 26		190 38 33		225 45 38	ns	2.0 4.5 6.0	Fig. 9
t _{THL} / t _{TLH}	output transition time		14 5 4	60 12 10		75 15 13		90 18 15	ns	2.0 4.5 6.0	Fig. 7
t _W	LE pulse width HIGH	80 16 14	14 5 4		100 20 17		120 24 20		ns	2.0 4.5 6.0	Fig. 8
t _{SU}	set-up time D _n to LE	50 10 9	3 1 1		65 13 11		75 15 13		ns	2.0 4.5 6.0	Fig. 10
t _H	hold time D _n to LE	35 7 6	3 1 1		45 9 8		55 11 9		ns	2.0 4.5 6.0	Fig. 10

DC CHARACTERISTICS FOR 74HCT

For the DC characteristics see chapter "HCMOS family characteristics", section "Family specifications".

Output capability: bus driver

I_{CC} category: MSI

Note to HCT types

The value of additional quiescent supply current (ΔI_{CC}) for a unit load of 1 is given in the family specifications. To determine ΔI_{CC} per input, multiply this value by the unit load coefficient shown in the table below.

INPUT	UNIT LOAD COEFFICIENT
D _n	0.15
LE	0.30
\overline{OE}	0.55

AC CHARACTERISTICS FOR 74HCT

GND = 0 V; t_r = t_f = 6 ns; C_L = 50 pF

SYMBOL	PARAMETER	T _{amb} (°C)						UNIT	TEST CONDITIONS		
		74HCT							V _{CC} V	WAVEFORMS	
		+25			-40 to +85		-40 to +125				
		min.	typ.	max.	min.	max.	min.				max.
t _{PHL} / t _{PLH}	propagation delay D _n to $\overline{Q_n}$		19	34		43		51	ns	4.5	Fig. 7
t _{PHL} / t _{PLH}	propagation delay LE to $\overline{Q_n}$		22	38		48		57	ns	4.5	Fig. 8
t _{PZH} / t _{PZL}	3-state output enable time \overline{OE} to $\overline{Q_n}$		19	35		44		53	ns	4.5	Fig. 9
t _{PHZ} / t _{PLZ}	3-state output disable time \overline{OE} to $\overline{Q_n}$		18	30		38		45	ns	4.5	Fig. 9
t _{THL} / t _{TLH}	output transition time		5	12		15		18	ns	4.5	Fig. 7
t _W	LE pulse width HIGH	16	5		20		24		ns	4.5	Fig. 8
t _{su}	set-up time D _n to LE	10	3		13		15		ns	4.5	Fig. 10
t _h	hold time D _n to LE	8	2		10		12		ns	4.5	Fig. 10

AC WAVEFORMS

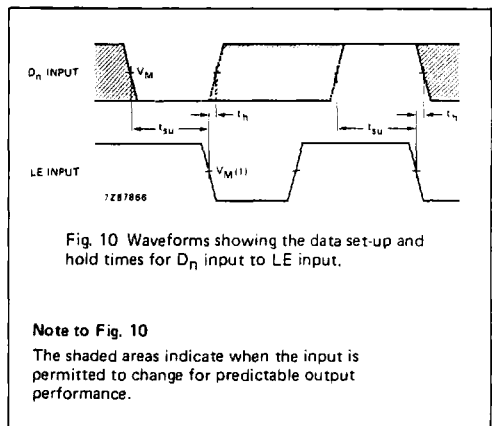
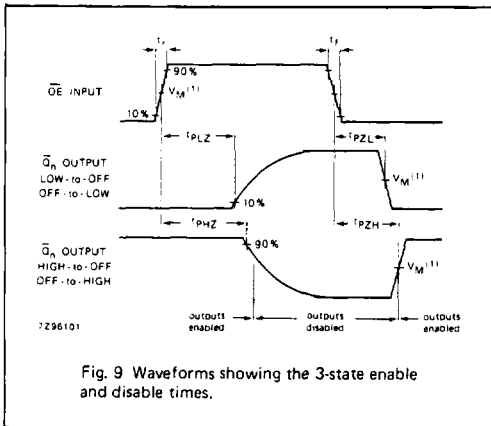
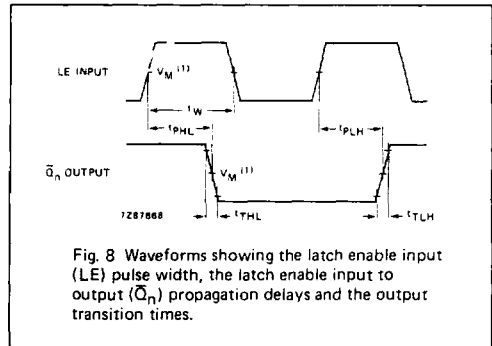
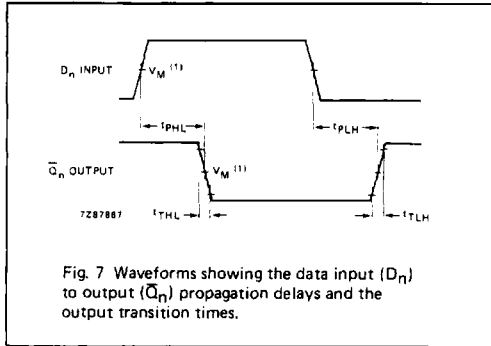

Note to Fig. 10

The shaded areas indicate when the input is permitted to change for predictable output performance.

Note to AC waveforms

- (1) HC : $V_M = 50\%$; $V_I = \text{GND to } V_{CC}$;
- HCT: $V_M = 1.3 \text{ V}$; $V_I = \text{GND to } 3 \text{ V}$.