

Product Features

- Compatible with LCX™ and LVT™ families of products
- Supports 5V Tolerant Mixed Signal Mode Operation
 - Input can be 3V or 5V
 - Output can be 3V or connected to 5V bus
- Advanced Low Power CMOS Operation
- Excellent output drive capability:
Balanced drives (12mA sink and source)
- 25Ω-Series resistor on outputs to reduce overshoot and undershoot
- Pin compatible with industry standard double-density pinouts
- Low ground bounce outputs
- Hysteresis on all inputs
- Industrial operating temperature range: -40°C to +85°C
- Multiple center pins and distributed Vcc/GND pins minimize switching noise
- Packages available:
 - 56-pin 240 mil wide plastic TSSOP (A56)
 - 56-pin 300 mil wide plastic SSOP (V56)

Product Description

Pericom Semiconductor's PI74LPT series of logic circuits are produced in the Company's advanced 0.6 micron CMOS technology, achieving industry leading speed grades.

The PI74LPT162Q952 has 16-bit registered transceivers organized with two sets of eight D-type latches with separate input and output controls for each set. For data flow from A to B, for example, the A-to-B Enable (xCEAB) input must be LOW to enter data from xAx. The data present on the A port will be clocked on the B register when xCLKAB toggles from LOW-to-HIGH. The xOEAB control performs the output enable function on the B port. Control of data from B to A is similar, but uses the xCEAB, xCLKAB, and xOEAB inputs. By connecting the control pins of the two independent transceivers together, a full 16-bit operation can be achieved. The output buffers are designed with a Power-Off disable allowing "live insertion" of boards when used as backplane drivers.

The PI74LPT162Q952 can be driven from either 3.3V or 5.0V devices allowing this device to be used as a translator in a mixed 3.3/5.0V system.

Logic Block Diagram

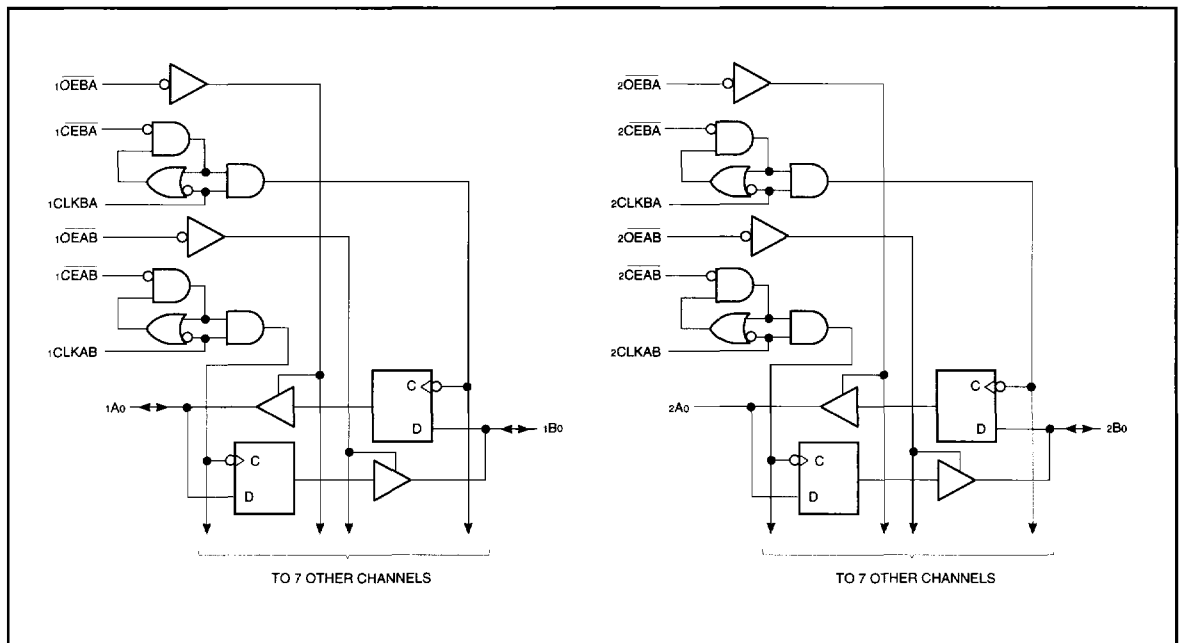

Product Pin Description

Pin Name	Description
\overline{xOEAB}	A-to-B Output Enable Input (A)
\overline{xOEBA}	B-to-A Output Enable Input (A)
\overline{xCEAB}	A-to-B Clock Enable Input (Ac)
\overline{xCEBA}	B-to-A Clock Enable Input (Ac)
\overline{xCLKAB}	A-to-B Clock Input
\overline{xCLKBA}	B-to-A Clock Input
\overline{xAx}	A-to-B Data Inputs or B-to-A
\overline{xBx}	B-to-A Data Inputs or B-to-A
GND	Ground
Vcc	Power

Product Pin Configuration

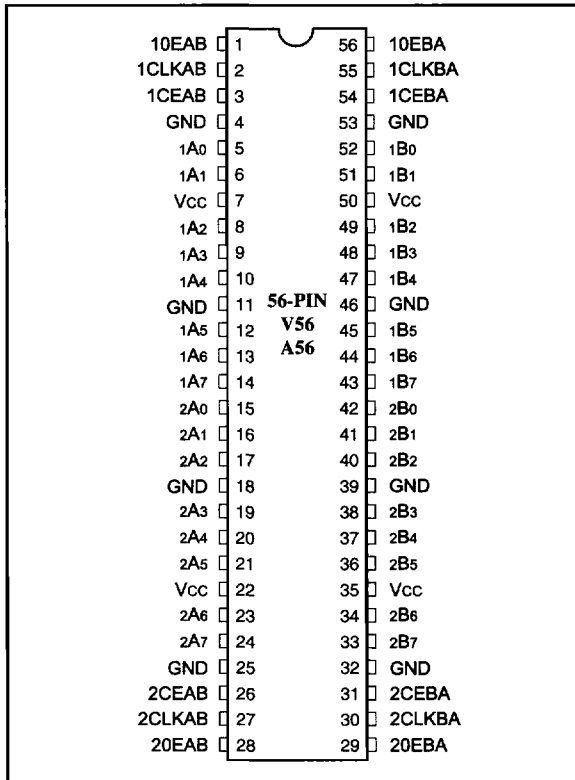

Truth Table^(1,2)

Inputs			
\overline{xCEAB}	\overline{xCLKAB}	\overline{xOEAB}	\overline{xAx}
H	X	L	X
X	L	L	X
L	↑	L	L
L	↑	L	H
X	X	H	X

Notes:

- H = High Voltage Level
L = Low Voltage Level
X = Don't Care or Irrelevant
↑ = LOW-to-HIGH Transition
Z = High Impedance
- A-to-B data flow shown. B-to-A flow control is the same, except using \overline{xCEBA} , \overline{xCLKBA} , and \overline{xOEBA} .
- Level of B before the indicated steady-state input conditions were established.

Maximum Ratings

(Above which the useful life may be impaired. For user guidelines, not tested)

Storage Temperature	-65°C to +150°C
Ambient Temperature with Power Applied	-40°C to +85°C
Supply Voltage to Ground Potential (Inputs & Vcc Only)	-0.5V to +7.0V
Supply Voltage to Ground Potential (Outputs & D/O Only) ..	-0.5V to +7.0V
DC Input Voltage	-0.5V to +7.0V
DC Output Current	120 mA
Power Dissipation	1.0W

Note:

Stresses greater than those listed under MAXIMUM RATINGS may cause permanent damage to the device. This is a stress rating only and functional operation of the device at these or any other conditions above those indicated in the operational sections of this specification is not implied. Exposure to absolute maximum rating conditions for extended periods may affect reliability.

DC Electrical Characteristics (Over the Operating Range, TA = -40°C to +85°C, VCC = 2.7V to 3.6V)

Parameters	Description	Test Conditions ⁽¹⁾	Min.	Typ ⁽²⁾	Max.	Units
VIH	Input HIGH Voltage (Input pins)	Guaranteed Logic HIGH Level	2.2	—	5.5	V
	Input HIGH Voltage (I/O pins)		2.0	—	5.5	V
VIL	Input LOW Voltage (Input and I/O pins)	Guaranteed Logic LOW Level	-0.5	—	0.8	V
IIH	Input HIGH Current (Input pins)	VCC = Max., VIN = 5.5V	—	—	±1	µA
	Input HIGH Current (I/O pins)	VCC = Max., VIN = VCC	—	—	±1	µA
IIL	Input LOW Current (Input pins)	VCC = Max., VIN = GND	—	—	±1	µA
	Input LOW Current (I/O pins)	VCC = Max., VIN = GND	—	—	±1	µA
IOZH	High Impedance Output Current (3-State Output pins)	VCC = Max., VOUT = 5.5V	—	—	±1	µA
IOZL		VCC = Max., VOUT = GND	—	—	±1	µA
VIK	Clamp Diode Voltage	VCC = Min., IIN = -18mA	—	-70	-1.2	V
IODH	Output HIGH Current	VCC = 3.3V, VIN = VIH or VIL, VO = 1.5V ⁽³⁾	-36	—	-110	mA
IODL	Output LOW Current	VCC = 3.3V, VIN = VIH or VIL, VO = 1.5V ⁽³⁾	25	—	100	mA
VOH	Output HIGH Voltage	VCC = Min., VIN = VIH or VIL, IOH = -12.0mA	2.4	3.0	—	V
VOL	Output LOW Voltage	VCC = Min., VIN = VIH or VIL, IOL = 12.0mA	—	0.40	0.55	V
IOS	Short Circuit Current ⁽⁴⁾	VCC = Max. ⁽³⁾ , VOUT ≤ GND - 60	-85	-240	mA	
IOFF	Power Down Disable	VCC = 0V, VIN or VOUT - 4.5V	—	—	±100	µA
VH	Input Hysteresis		—	150	—	mV

Notes:

1. For Max. or Min. conditions, use appropriate value specified under Electrical Characteristics for the applicable device type.
2. Typical values are at VCC = 3.3V, +25°C ambient and maximum loading.
3. Not more than one output should be shorted at one time. Duration of the test should not exceed one second.
4. This parameter is guaranteed but not tested.
5. VOH = VCC - 0.6V at rated current.

Power Supply Characteristics

Parameters	Description	Test Conditions ⁽¹⁾		Min.	Typ ⁽²⁾	Max.	Units
I _{CC}	Quiescent Power Supply Current	V _{CC} = Max.	V _{IN} = GND or V _{CC}		0.1	10	μA
ΔI _{CC}	Quiescent Power Supply Current TTL Inputs HIGH	V _{CC} = Max.	V _{IN} = V _{CC} - 0.6V ⁽³⁾		2.0	30	μA
I _{CCD}	Dynamic Power Supply ⁽⁴⁾	V _{CC} = Max., Outputs Open x $\overline{\text{OE}}$ = GND One Bit Toggling 50% Duty Cycle	V _{IN} = V _{CC} V _{IN} = GND		50	75	μA/ MHz
I _C	Total Power Supply Current ⁽⁶⁾	V _{CC} = Max., Outputs Open f _i = 10 MHz 50% Duty Cycle x $\overline{\text{OE}}$ = GND One Bit Toggling	V _{IN} = V _{CC} - 0.6V V _{IN} = GND		0.6	2.3	mA
		V _{CC} = Max., Outputs Open f _i = 2.5 MHz 50% Duty Cycle x $\overline{\text{OE}}$ = GND 16 Bits Toggling	V _{IN} = V _{CC} - 0.6V V _{IN} = GND		2.1	4.7 ⁽⁵⁾	

Notes:

- For Max. or Min. conditions, use appropriate value specified under Electrical Characteristics for the applicable device.
- Typical values are at V_{CC} = 3.3V, +25°C ambient.
- Per TTL driven input; all other inputs at V_{CC} or GND.
- This parameter is not directly testable, but is derived for use in Total Power Supply Calculations.
- Values for these conditions are examples of the I_{CC} formula. These limits are guaranteed but not tested.
- I_C = I_{QUIESCENT} + I_{INPUTS} + I_{DYNAMIC}

$$I_C = I_{CC} + \Delta I_{CC} D_H N_T + I_{CCD} (f_{CP}/2 + f_i N_i)$$

$$I_{CC} = \text{Quiescent Current (I}_{CC1}, I_{CC2} \text{ and } I_{CC3})$$

$$\Delta I_{CC} = \text{Power Supply Current for a TTL High Input}$$

$$D_H = \text{Duty Cycle for TTL Inputs High}$$

$$N_T = \text{Number of TTL Inputs at } D_H$$

$$I_{CCD} = \text{Dynamic Current Caused by an Input Transition Pair (HLH or LHL)}$$

$$f_{CP} = \text{Clock Frequency for Register Devices (Zero for Non-Register Devices)}$$

$$N_{CP} = \text{Number of Clock Inputs at } f_{CP}$$

$$f_i = \text{Input Frequency}$$

$$N_i = \text{Number of Inputs at } f_i$$

All currents are in milliamps and all frequencies are in megahertz.

Switching Characteristics over Operating Range⁽¹⁾

Parameters	Description	Conditions ⁽²⁾	LPT162Q952A		LPT162Q952B		LPT162Q952C		Units
			Com.		Com.		Com.		
			Min. ⁽³⁾	Max.	Min. ⁽³⁾	Max.	Min. ⁽³⁾	Max.	
tPLH	Propagation Delay	CL = 50pF RL = 500Ω	2.0	10.0	2.0	7.5	2.0	6.3	ns
tPHL	xCLKAB, xCLKBA to xBx, xAx								
tpZH	Output Enable Time		1.5	10.5	1.5	8.0	1.5	7.0	ns
tpZL	xOEBA, xOEAB to xAx, xBx								
tpHZ	Output Disable Time ⁽⁴⁾		1.5	10.0	1.5	7.5	1.5	6.5	ns
tpLZ	xOEBA, xOEAB to xAx, xBx								
tsu	Set-up Time HIGH or LOW		2.5	—	2.5	—	2.5	—	ns
	xAx, xBx to xCLKAB, xCLKBA								
th	Hold Time HIGH or LOW		2.0	—	2.0	—	2.0	—	ns
	xAx, xBx to xCLKAB, xCLKBA								
tsu	Setup Time HIGH or LOW	3.0	—	3.0	—	3.0	—	ns	
	xCEAB, xCEBA to xCLKAB, xCLKBA								
th	Hold Time HIGH or LOW	2.0	—	2.0	—	2.0	—	ns	
	xCEAB, xCEBA to xCLKAB, xCLKBA								
tw	Pulse Width HIGH ⁽⁴⁾ or LOW, xCLKAB or xCLKBA	3.0	—	3.0	—	3.0	—	ns	
tsk(o)	Output Skew ⁽⁵⁾	—	0.5	—	0.5	—	0.5	ns	

Notes:

1. Propagation Delays and Enable/Disable times are with $V_{CC} = 3.3V \pm 0.3V$, normal range. For $V_{CC} = 2.7V$, extended range, all Propagation Delays and Enable/Disable times should be degraded by 20%.
2. See test circuit and waveforms.
3. Minimum limits are guaranteed but not tested on Propagation Delays.
4. This parameter is guaranteed but not production tested.
5. Skew between any two outputs, of the same package, switching in the same direction. This parameter is guaranteed by design.

Capacitance ($T_A = 25^\circ C$, $F = 1$ MHz)

Parameters ⁽¹⁾	Description	Test Conditions	Typ.	Max.	Units
CIN	Input Capacitance	$V_{IN} = 0V$	4.5	6	pF
COUT	Output Capacitance	$V_{out} = 0V$	5.5	8	

Note:

1. This parameter is determined by device characterization but it not production tested.