

PIN STRIP HEADERS

INCLUDING DESIGN INFORMATION ON PROGRAMMING JUMPER SWITCHES

Provides a convenient, reliable and cost effective interface

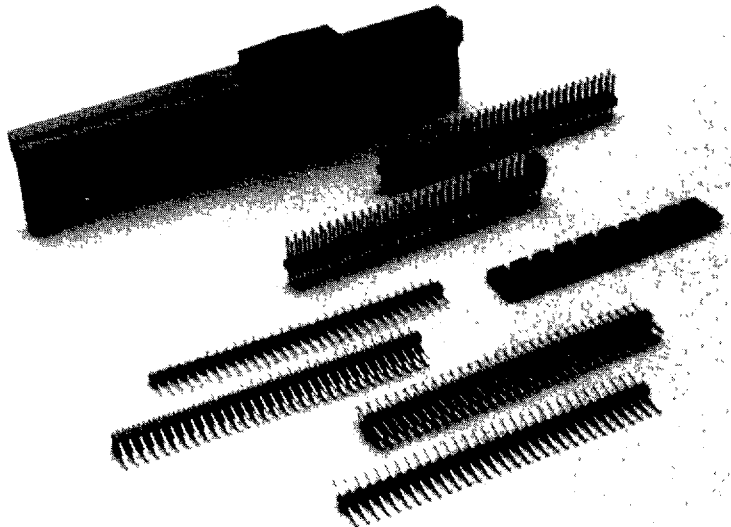

Description/Application

Pin Strip Headers are designed to provide a convenient, reliable and cost effective interface when mated with Female Sockets or Flexpac™ Female Socket systems. Available in single or double row versions, headers can be easily separated at desired lengths. Separations are clean and smooth, leaving no rough-end circuit conditions.

Strip Headers are available with two mating pin lengths (.240" and .318") and two solder tail pin lengths to accommodate .062" through .125" board thicknesses.

Design Considerations

- Square posts of .025" on .100" x .100" centerline spacing allow mating with Female Sockets, Flexpac™ Female Socket systems and other commonly used connector interfaces
- Straight and right angle post configurations permit mounting versatility
- Connector body material: glass-filled polyester (94V-0 flammability rating)
- Three plating options: 30 microinches gold, tin/lead, 15 microinches gold
- Strips are available in two sizes—single row strips with 32 contacts; double row strips with 64 contacts; consult factory for specific discrete component sizes
- Connector posts are on .100" x .100" centerline spacing

The Programming Jumper Switch is designed to provide a reliable mating interface that can be used with either square or round pins. The Jumpers feature a positive connection to the male pin and virtually eliminate shock or vibration accidents which may result in de-programming.

The Programming Jumper Switches dramatically reduce applied costs and are a reliable alternative to conventional printed circuit board switches.

Installation Tools:

Break-off Tool for Pin Strip Headers — P/N 779-6860

Standard Product Options

The information below provides a general overview of this product family.

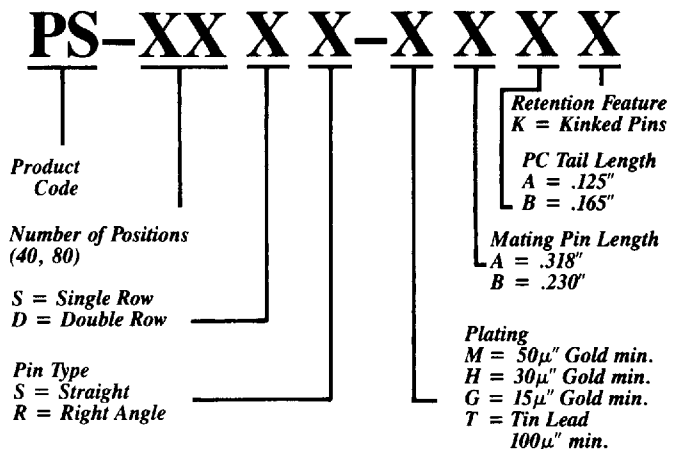

PIN STRIP HEADERS

RECOMMENDED PC BOARD HOLE PATTERN

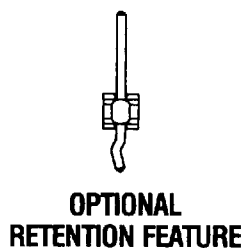
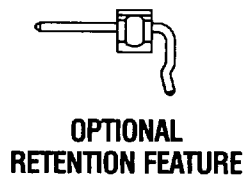
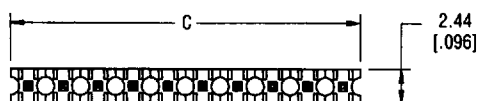
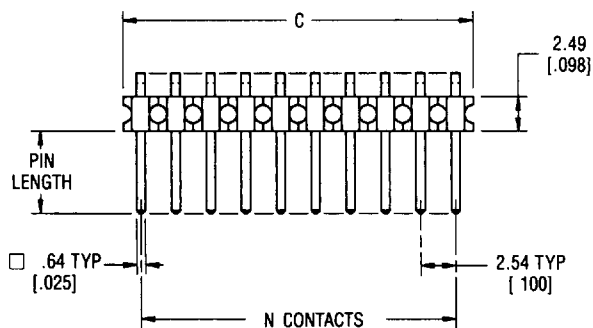
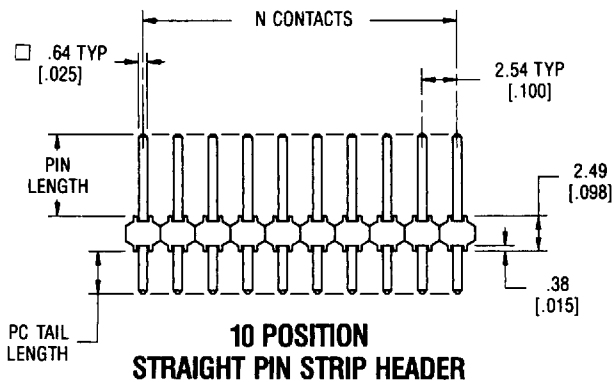
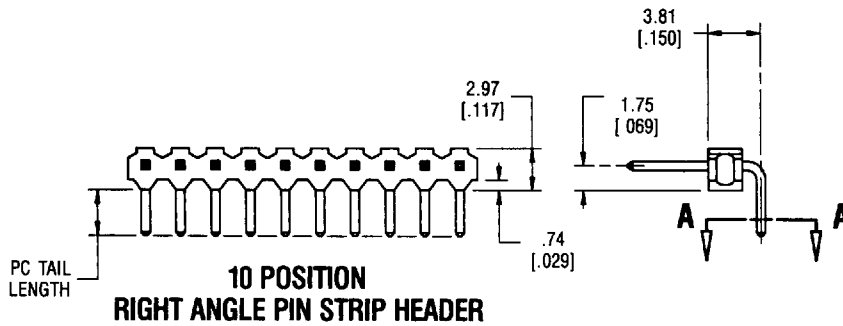
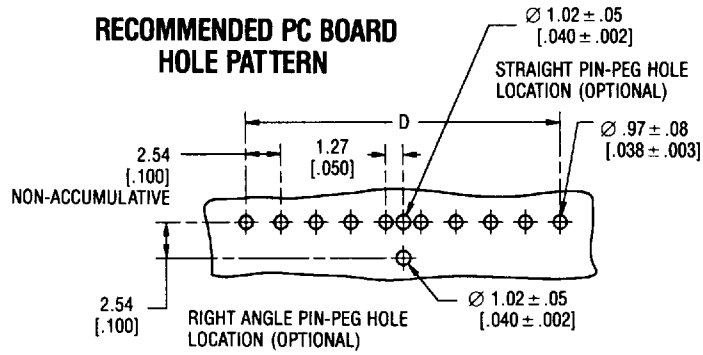

40	4.000	3.900
39	3.900	3.800
38	3.800	3.700
37	3.700	3.600
36	3.600	3.500
35	3.500	3.400
34	3.400	3.300
33	3.300	3.200
32	3.200	3.100
31	3.100	3.000
30	3.000	2.900
29	2.900	2.800
28	2.800	2.700
27	2.700	2.600
26	2.600	2.500
25	2.500	2.400
24	2.400	2.300
23	2.300	2.200
22	2.200	2.100
21	2.100	2.000
20	2.000	1.900
19	1.900	1.800
18	1.800	1.700
17	1.700	1.600
16	1.600	1.500
15	1.500	1.400
14	1.400	1.300
13	1.300	1.200
12	1.200	1.100
11	1.100	1.000
10	1.000	.900
9	.900	.800
8	.800	.700
7	.700	.600
6	.600	.500
5	.500	.400
4	.400	.300
3	.300	.200
2	.200	.100
1	.100	—
N	C	D

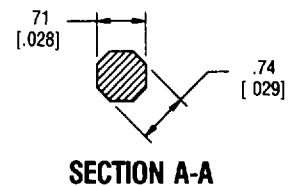

A

PIN STRIP HEADERS

RECOMMENDED PC BOARD HOLE PATTERN

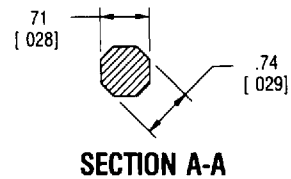
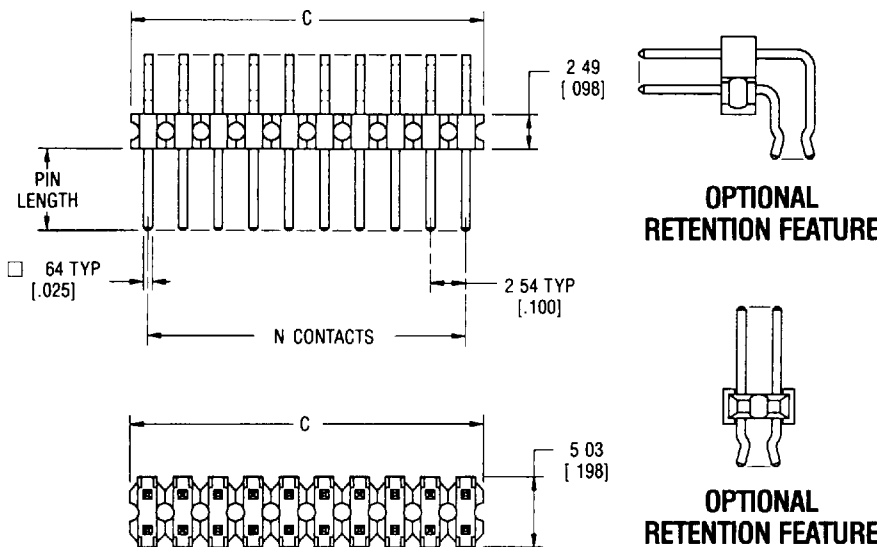
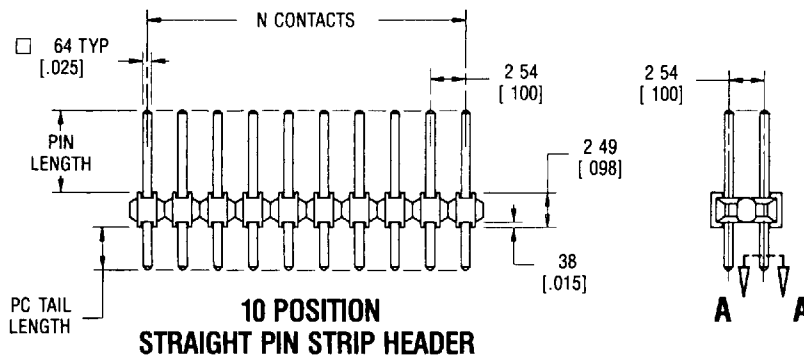
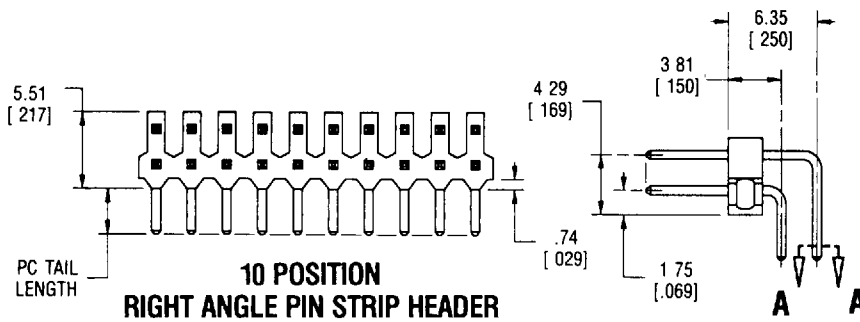
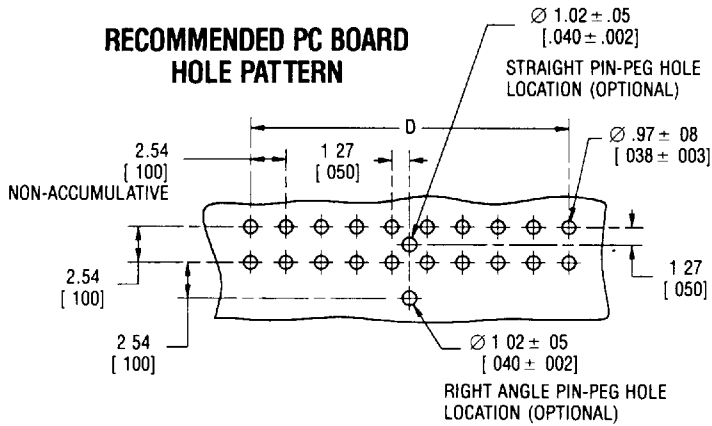

80	4.000	3.900
78	3.900	3.800
76	3.800	3.700
74	3.700	3.600
72	3.600	3.500
70	3.500	3.400
68	3.400	3.300
66	3.300	3.200
64	3.200	3.100
62	3.100	3.000
60	3.000	2.900
58	2.900	2.800
56	2.800	2.700
54	2.700	2.600
52	2.600	2.500
50	2.500	2.400
48	2.400	2.300
46	2.300	2.200
44	2.200	2.100
42	2.100	2.000
40	2.000	1.900
38	1.900	1.800
36	1.800	1.700
34	1.700	1.600
32	1.600	1.500
30	1.500	1.400
28	1.400	1.300
26	1.300	1.200
24	1.200	1.100
22	1.100	1.000
20	1.000	.900
18	.900	.800
16	.800	.700
14	.700	.600
12	.600	.500
10	.500	.400
8	.400	.300
6	.300	.200
4	.200	.100
2	.100	—
N	C	D